

# AIRDEVIL™

## OWNER'S MANUAL

AGES 8 AND UP

**WARNING:** Changes or modifications to this unit not expressly approved by the party responsible for compliance could void the user's authority to operate the equipment.

### SAFETY PRECAUTIONS

This vehicle is not recommended for children under the age of 8 years. Please read all of the instructions before operating this vehicle. Always follow general safety rules while operating vehicle: avoid hitting pets, furniture or people. Do not pick up vehicle while it is in motion. Keep hands, hair and clothing away from this vehicle when the power switch is turned to the "ON" position. Remove battery pack when vehicle is stored. **AVOID TIRE CONTACT ON PAINTED OR VARNISHED SURFACES.** Recommend outdoor play with this vehicle.

**Kenner**

© 1996 HASBRO, INC.,  
Pawtucket, Rhode Island 02862.  
All Rights Reserved.

Made in China

## BATTERY REQUIREMENTS / INSTALLATION FOR VEHICLE

To operate your vehicle, you will need a **9.6 Volt Rechargeable NiCd Battery Pack (sold separately)**. Follow manufacturer's charging instructions on the rechargeable battery pack. PLEASE NOTE: The battery pack will become hot during use, so care should be taken whenever you handle it.

1. Insert a large coin in battery compartment slot as shown, push in and down as you slide cover off. **DO NOT PRY.**

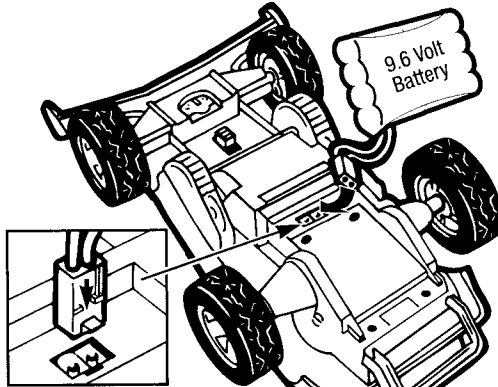
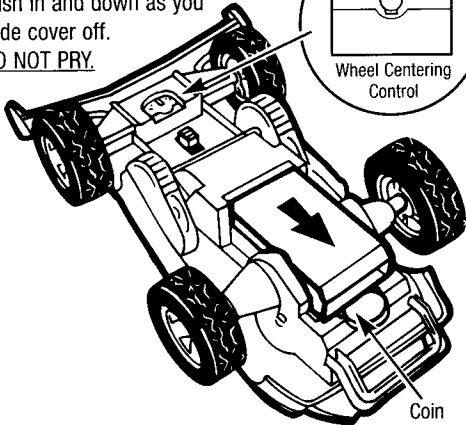
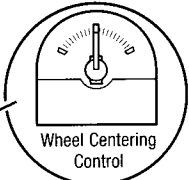

2. Connect battery wire plug as shown.

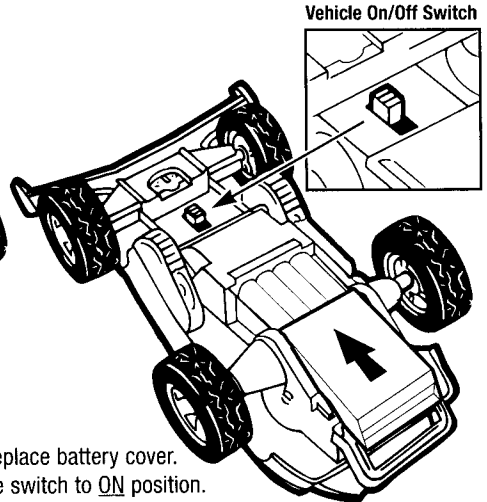

3. Replace battery cover. Move switch to **ON** position.

### BATTERY NOTE:

Kenner does not manufacture battery packs. When you have purchased one, please follow the manufacturer's instructions for use. Depending upon the type you choose, you should expect that the **initial charge might require 4 hours and last 8-10 minutes** in the intense operation of your Airdevil™ vehicle. Each time you charge the battery, you should get longer performance as you "break in" your battery, until you enjoy operation that is up to twice as long as that of the initial charge.

## BATTERY REQUIREMENTS / INSTALLATION FOR TRANSMITTER

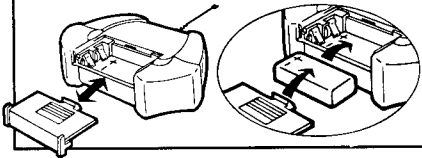

To operate your transmitter you will need a 9 Volt Alkaline Battery (sold separately). Remove battery cover as shown and install a new 9 Volt Alkaline Battery. Replace cover. Press either pad and the red LED light will come on. This will show you that the battery is good and the transmitter is ready for operation.

**IMPORTANT:** Main vehicle switch must be in the ON position to receive commands from the transmitter.

## PROPER OPERATION AND STORAGE OF YOUR VEHICLE

- Best operation** of vehicle is on an OUT-OF-DOORS textured paved surface to avoid furniture damage and minimize noise level.
- Always** operate your vehicle within a range of 75 feet from you.
- Always** operate your vehicle on dry surfaces away from cars and other full-size vehicles.
- Always store your vehicle in a cool, dry place and off of painted or varnished surfaces.**
- Storage of vehicle.** Always turn main vehicle switch OFF after play and remove battery.
- Avoid** water or damp locations which may damage the vehicle's electronics. If your vehicle ACCIDENTALLY gets wet and stops running, let it dry overnight before trying to run it again.
- Avoid** operating around CB radios, baby monitors, cordless phones, electrical appliances, electric baseboard heaters, high voltage electrical wires and large, steel-reinforced concrete buildings all of which may cause interference.
- Avoid** running your vehicle and another vehicle on the same frequency. If you want to race another vehicle, use a 27 MHz Airdevil™ vehicle against a 49 MHz Airdevil™ vehicle.

## LABEL APPLICATION

### LABEL APPLICATION

Apply labels using the numbers on the label sheet, the below illustrations and the package photograph as a guide.

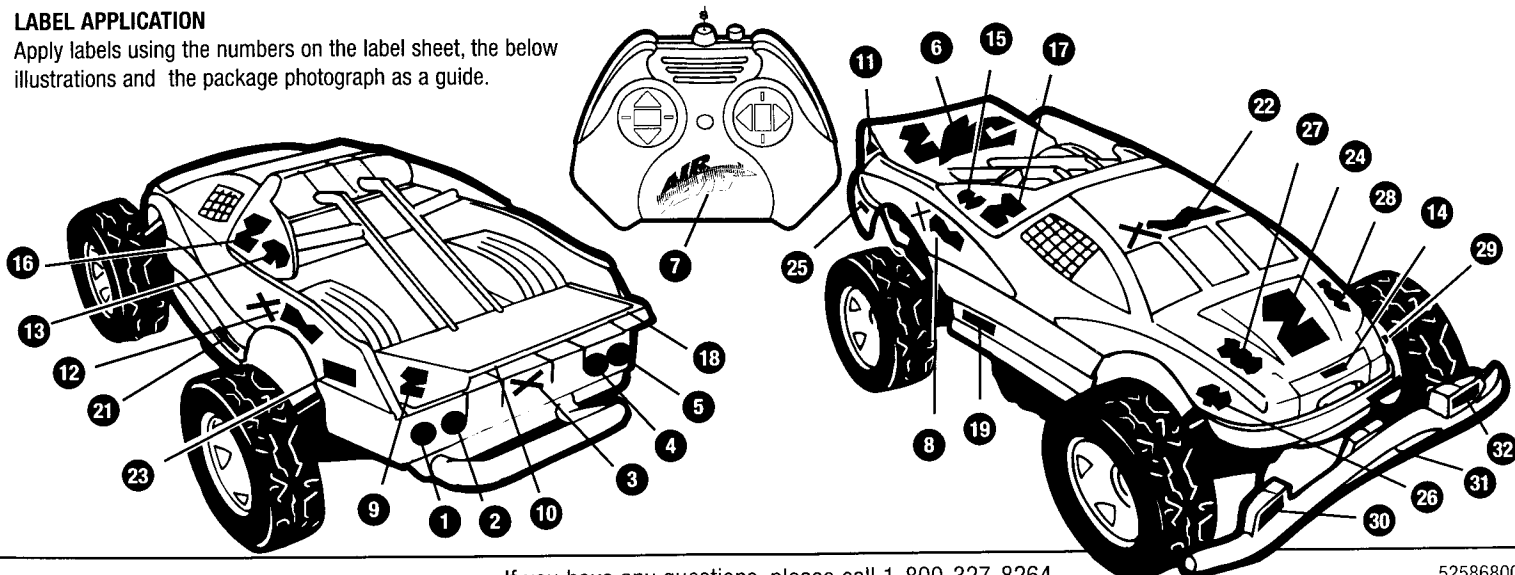

If you have any questions, please call 1-800-327-8264

52586800

## DIRECTION AND JUMP CONTROLS

**IMPORTANT:** The Top "Jump Button" will work only when the forward "Drive Button" is being pushed.

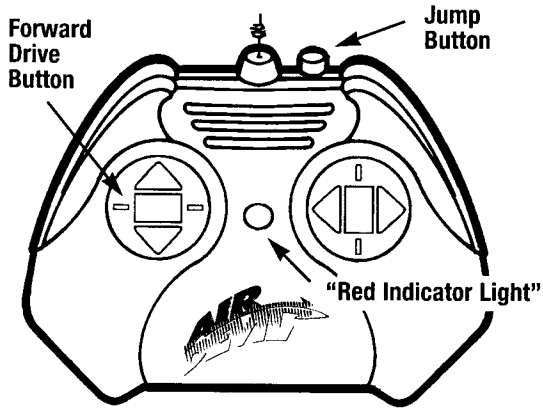

Press button(s) and vehicle will move in the direction indicated by the arrows. Press top jump button as mentioned above to make vehicle jump.

FORWARD DRIVE  
↑  
↓  
REVERSE

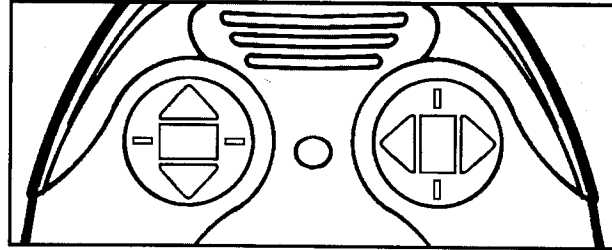

## FOR BEST PERFORMANCE FOLLOW THESE SIMPLE RULES:

1. The faster Air Devil™ goes, the higher and further it will jump. (Up to 12" high and 5' in length.)

2. Always start with a fresh battery.  
Make sure main vehicle switch under vehicle is turned on.

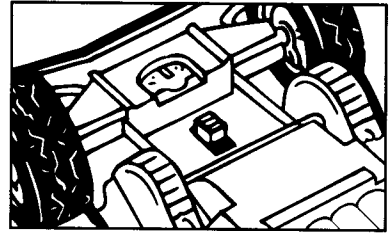

3. Make sure the launcher cam is in the start position.

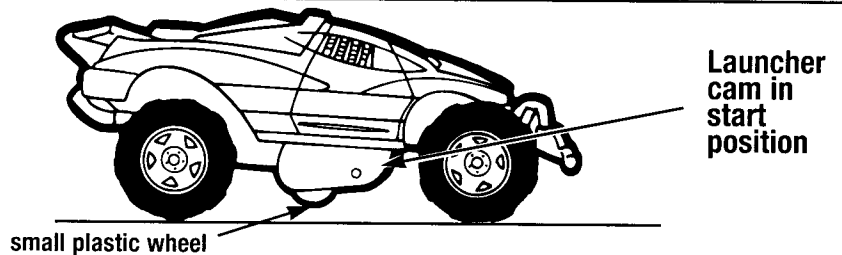

4. Choose a clean smooth hard pavement to run your vehicle on. A slight downward grade will improve speed.

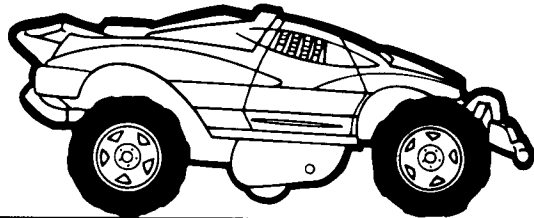

5. While running vehicle forward, (Drive button pushed and "red indicator light" on) you also push the "Jump Button". Remember both buttons must be pushed at the same time.

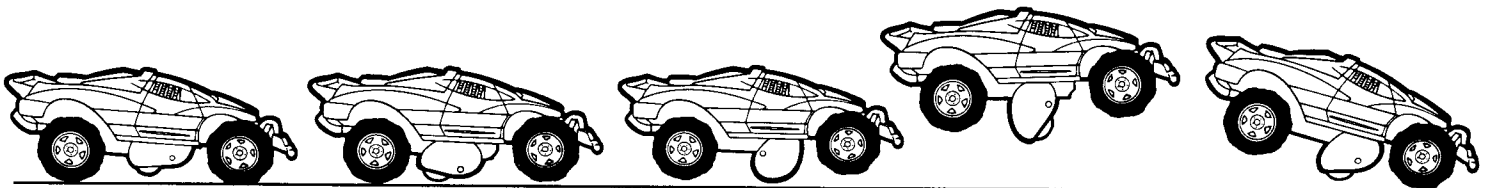

This device complies with Part 15 of Fcc Rules. Operation is subject to the following two conditions: (1) This device may not cause harmful interference, and (2) This device must accept any interference that may cause undesired operation.

## GUIDE FOR TROUBLESHOOTING - Check the points below if you are experiencing difficulty. Sometimes an apparent malfunction is the result of a simple cause and effect as shown below.

SYMPTOM	PROBABLE CAUSE	CORRECTION
Vehicle runs slowly or will not run. Vehicle does not jump or jumps poorly.	<ul style="list-style-type: none"> <li>• Main Vehicle switch not ON.</li> <li>• Weak or uncharged 9.6 volt vehicle battery.</li> <li>• Weak 9 volt controller battery.</li> <li>• Using wrong transmitter.</li> <li>• Not pressing forward drive control at the same time pressing jump button.</li> </ul>	<ul style="list-style-type: none"> <li>* Check vehicle switch, must be on.</li> <li>* Charge battery or replace.</li> <li>* Replace with fresh alkaline battery.</li> <li>* Use correct transmitter.</li> <li>* Press forward drive control and jump button at same time.</li> </ul>
Red light on controller doesn't light when either pad is pressed.	<ul style="list-style-type: none"> <li>• Controller battery weak or not connected.</li> </ul>	<ul style="list-style-type: none"> <li>* Check connections and replace battery if required.</li> </ul>
Erratic operation or only short range possible.	<ul style="list-style-type: none"> <li>• Radio interference likely.</li> </ul>	<ul style="list-style-type: none"> <li>* Change location (see point 6, PROPER OPERATION SECTION)</li> </ul>
Short vehicle battery life.	<ul style="list-style-type: none"> <li>• Initial charge will give 8 to 10 minutes of operation.</li> </ul>	<ul style="list-style-type: none"> <li>* Recharge vehicle battery. Once drained the battery will have longer life with each recharging. About 10 minutes of life is typical with this type of radio controlled vehicle.</li> </ul>
Vehicle doesn't work after going through water or snow.	<ul style="list-style-type: none"> <li>• Water in the electronics area.</li> </ul>	<ul style="list-style-type: none"> <li>* Vehicle will take several hours to dry. Allow to dry overnight before trying again.</li> </ul>