

OVER 12 months

06032

PLAYSKOOL®

Around Town Activity Center™

Thank you for choosing this unique activity toy!

Includes 4 x 1.5V "D"/R20 batteries. Alkaline batteries recommended. Phillips/crosshead screwdriver (not included) required for battery installation.



PLAY FEATURES

PLEASE NOTE: This product is shipped in "Demo" mode. Slide switch on back of toy to "On" for full use at home.

The AROUND TOWN ACTIVITY CENTER set features lots of air-powered activities and happy music to amuse and fascinate your toddler! To activate the toy, push the radar dish, move the fire hydrant, move the train gate, or push the elevator button.

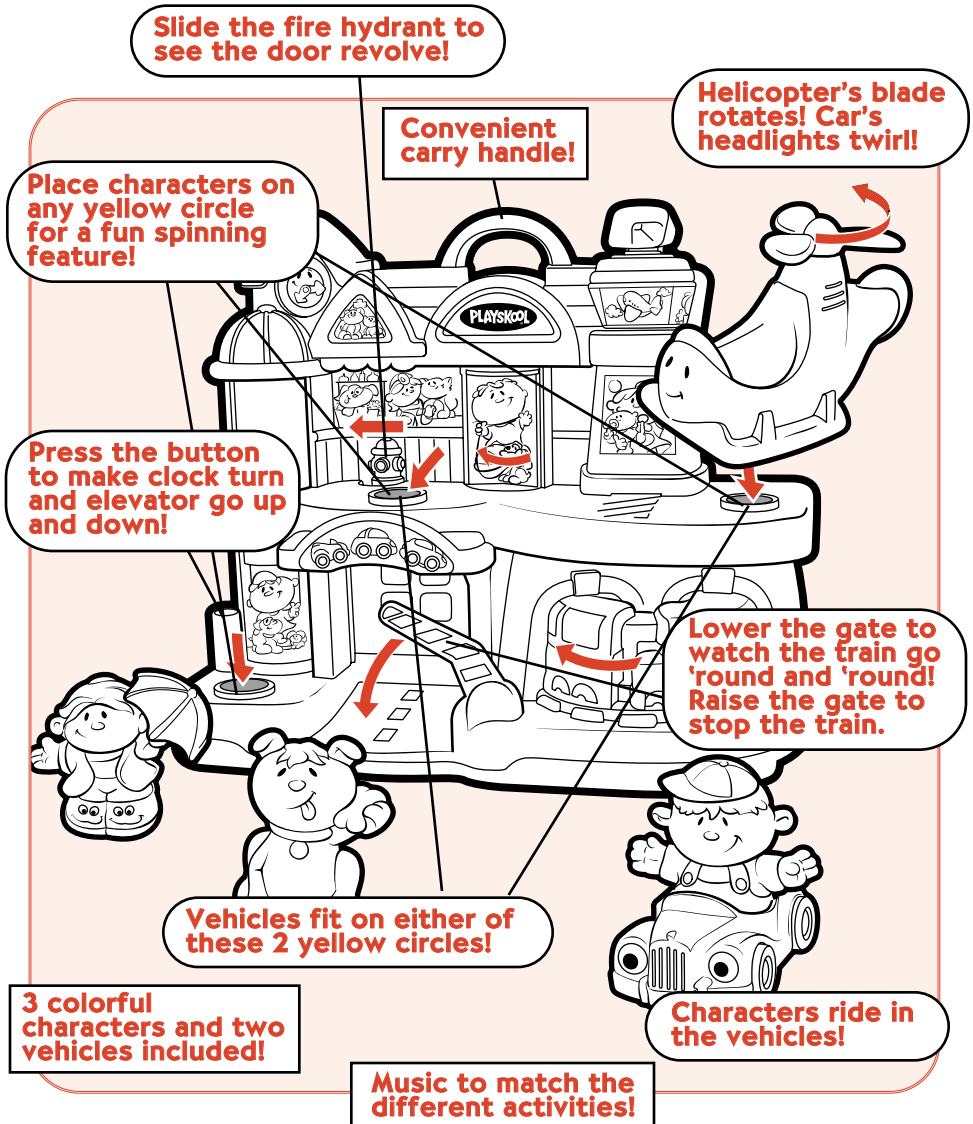

IMPORTANT NOTE:

When one or more air-powered activity functions improperly (though others may work properly), you will need to replace the batteries.

When storing toy, turn the switch to OFF to prevent accidental activation.

TO REPLACE BATTERIES

Use a Phillips/crosshead screwdriver to loosen screws in battery compartment door (screws remains attached to door). Remove and discard old batteries. Insert 4 fresh "D"/LR20 (1.5V) alkaline batteries. Replace door and tighten screws.

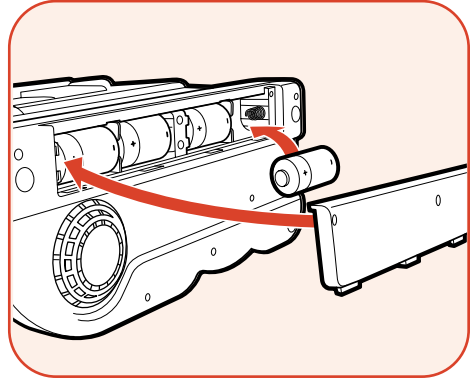

⚠ CAUTION: TO AVOID BATTERY LEAKAGE

- 1) Be sure to insert the batteries correctly and always follow the toy and battery manufacturers' instructions;
- 2) Do not mix old and new batteries or alkaline, standard (carbon-zinc) or rechargeable (nickel-cadmium) batteries;
- 3) Always remove weak or dead batteries from the product.

IMPORTANT: BATTERY INFORMATION

Please retain this information for future reference.

Batteries should be replaced by an adult.

⚠ CAUTION:

1. Always follow the instructions carefully. Use only batteries specified and be sure to insert them correctly by matching the + and - polarity markings.
2. Do not mix old batteries and new batteries or standard (carbon-zinc) with alkaline batteries.
3. Remove exhausted or dead batteries from the product.
4. Remove batteries if product is not to be played with for a long time.
5. Do not short circuit the supply terminals.
6. Should this product cause, or be affected by, local electrical interference, move it away from other electrical equipment. Reset (switching off and back on again or removing and re-inserting batteries) if necessary.
7. **RECHARGEABLE BATTERIES:** Do not mix these with any other types of battery. Always remove from the product before recharging. Recharge batteries under adult supervision. **DO NOT RECHARGE OTHER TYPES OF BATTERIES.**

FCC STATEMENT

This equipment has been tested and found to comply with the limits for a Class B digital device, pursuant to part 15 of the FCC Rules. These limits are designed to provide reasonable protection against harmful interference in a residential installation. This equipment generates, uses and can radiate radio frequency energy, and, if not installed and used in accordance with the instructions, may cause harmful interference to radio communications. However, there is no guarantee that interference will not occur in a particular installation. If this equipment does cause harmful interference to radio or television reception, which can be determined by turning the equipment off and on, the user is encouraged to try to correct the interference by one or more of the following measures:

- Reorient or relocate the receiving antenna.
- Increase the separation between the equipment and the receiver.
- Consult the dealer or an experienced radio/TV technician for help.

