



B.A.T.V.TM

ALL-TERRAIN VEHICLE

Batman and all related elements are the property of DC Comics Inc. TM and © 1993 All Rights Reserved.

Kemper[®]

* @ Kemper Products, A Division of Tonka Corporation, Cincinnati, Ohio 45202

GETTING READY

1 Apply labels following the numbers on the label sheet using these illustrations as a guide.

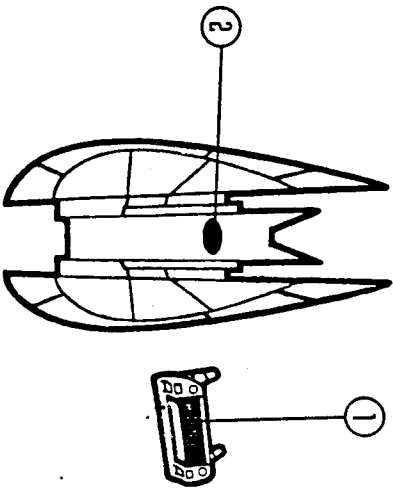

2 Press roller blade wheels to skis.

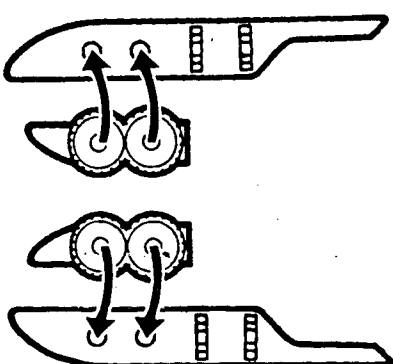

4 Press bat-shaped hub caps onto each large wheel.

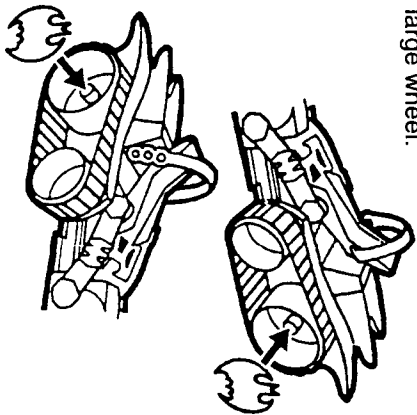

5 Snap dash to hood shield. Make sure control laser rotates through the slots.

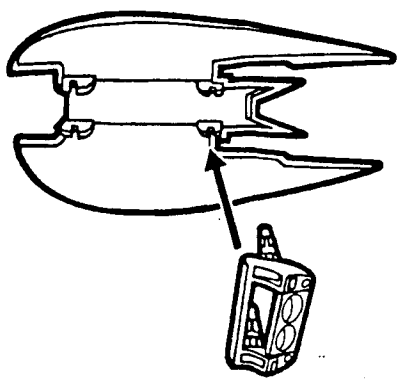

7 Lower hood shield. Make sure control laser is down.

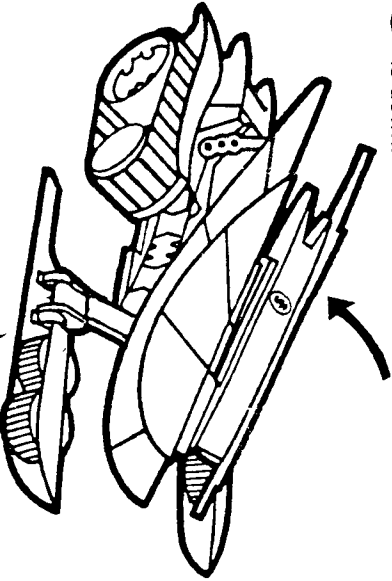

8 Insert dart missile into front of vehicle until it snaps into place.

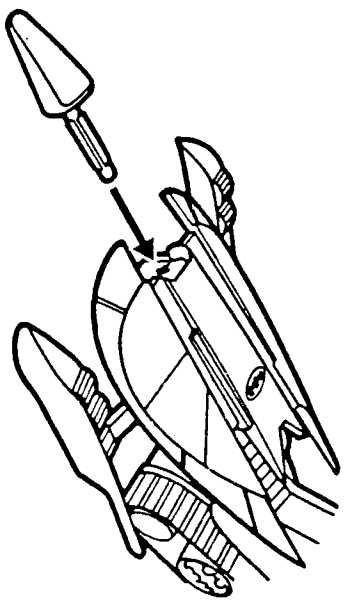

3 Snap ski assembly onto vehicle.

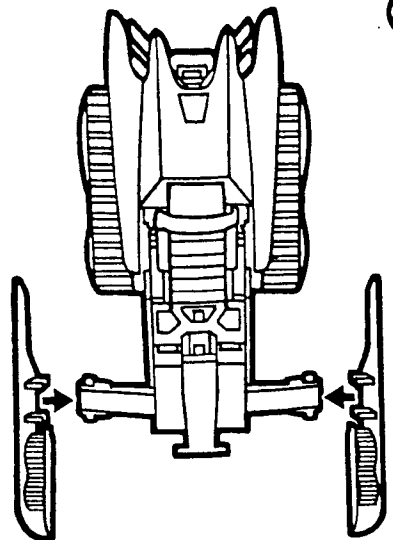

6 Snap hood shield onto front of vehicle.

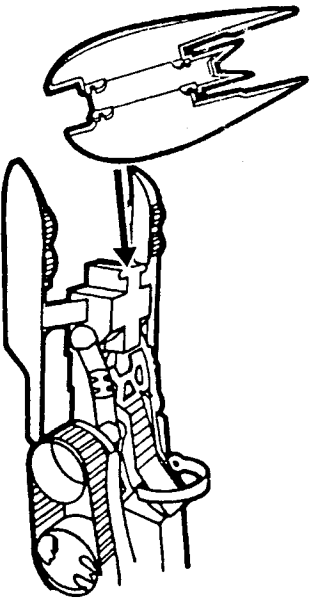

READY FOR ACTION

9 With skis down and hood up, secure Batman® figure into seat with belt.

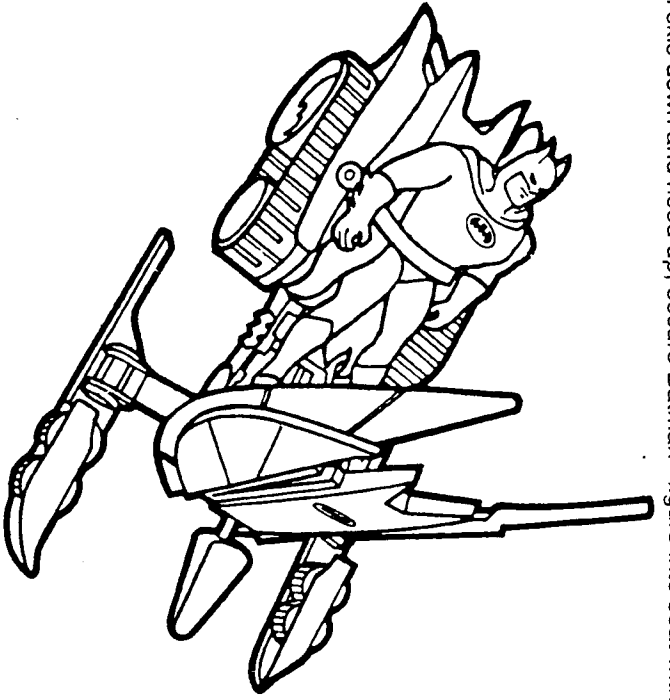

11 To get ready for battle, pull back on engine block and manually rotate skis to roller blade position. Pivot laser weapons forward.

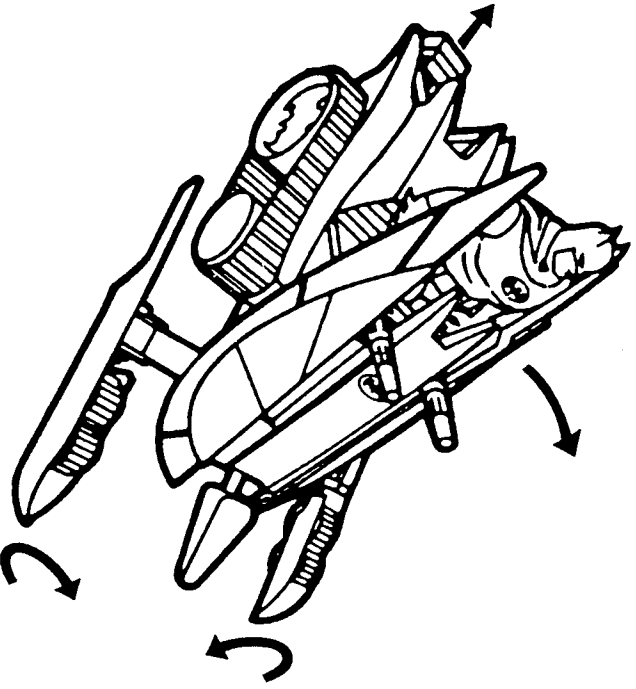

10 Lower shield for action on land or snow. The Batman® All-Terrain Vehicle™ is an effective crime fighting machine!

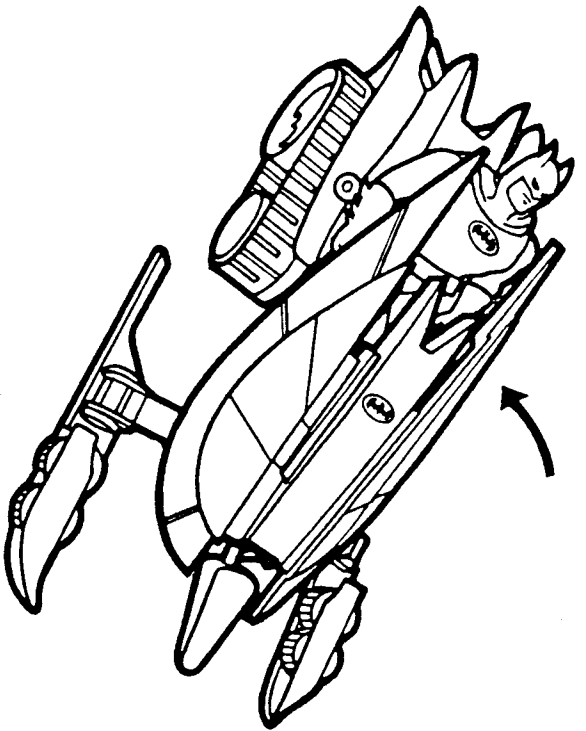

Note: missile does not fire in this mode.

12 Push down on tail pipes to fire dart missile.

