



Funtime Trike™

INSTRUCTIONS

Join that lovable dinosaur, Barney, on the free-rolling Funtime Trike from Playskool! This sleek, sturdy cycle offers two ways to ride – as a foot-to-floor vehicle for beginners, and a pedal-powered trike for more experienced riders. Includes a special storage trunk for toys with a clicking key to lift open the door. There's a lot to like about having a trike . . . especially when Barney comes along for the ride!

PLEASE KEEP THIS GUIDE AND ALL LITERATURE FOR FUTURE REFERENCE

Adults Please Note: This product should be assembled by an adult. Periodically check all hardware to be sure it is secure. Please read instructions prior to assembly. Study each step carefully to familiarize yourself with procedure and parts. Refer to back page for illustrated parts list. For easier assembly, trim excess plastic from all parts before starting.

WARNING – Contains small parts which may present a choking hazard to children under three.

TOOLS REQUIRED (NOT INCLUDED): Hammer, Phillips® and regular screwdrivers and a small block of wood.

CAUTION: ADULT SUPERVISION AND INSTRUCTION REQUIRED REGARDING THE PROPER USE OF THIS TOY. THIS RIDE-ON TOY SHOULD NOT BE USED NEAR SWIMMING POOLS, ON OR NEAR HILLS, ROADWAYS, SLOPED DRIVEWAYS, ALLEYS OR STEPS. SHOES MUST BE WORN AT ALL TIMES. ONLY ONE RIDER AT A TIME. DO NOT RIDE AFTER DARK. DO NOT CARRY ANYTHING, PARTICULARLY OBJECTS THAT IMPAIR VISION, WHILE RIDING THIS TOY. DO NOT LEAVE CHILD UNATTENDED WHILE RIDING THIS TOY.

Remove all pieces from plastic bags and discard bags IMMEDIATELY. Please keep all small parts, hardware and plastic bags out of children's reach.

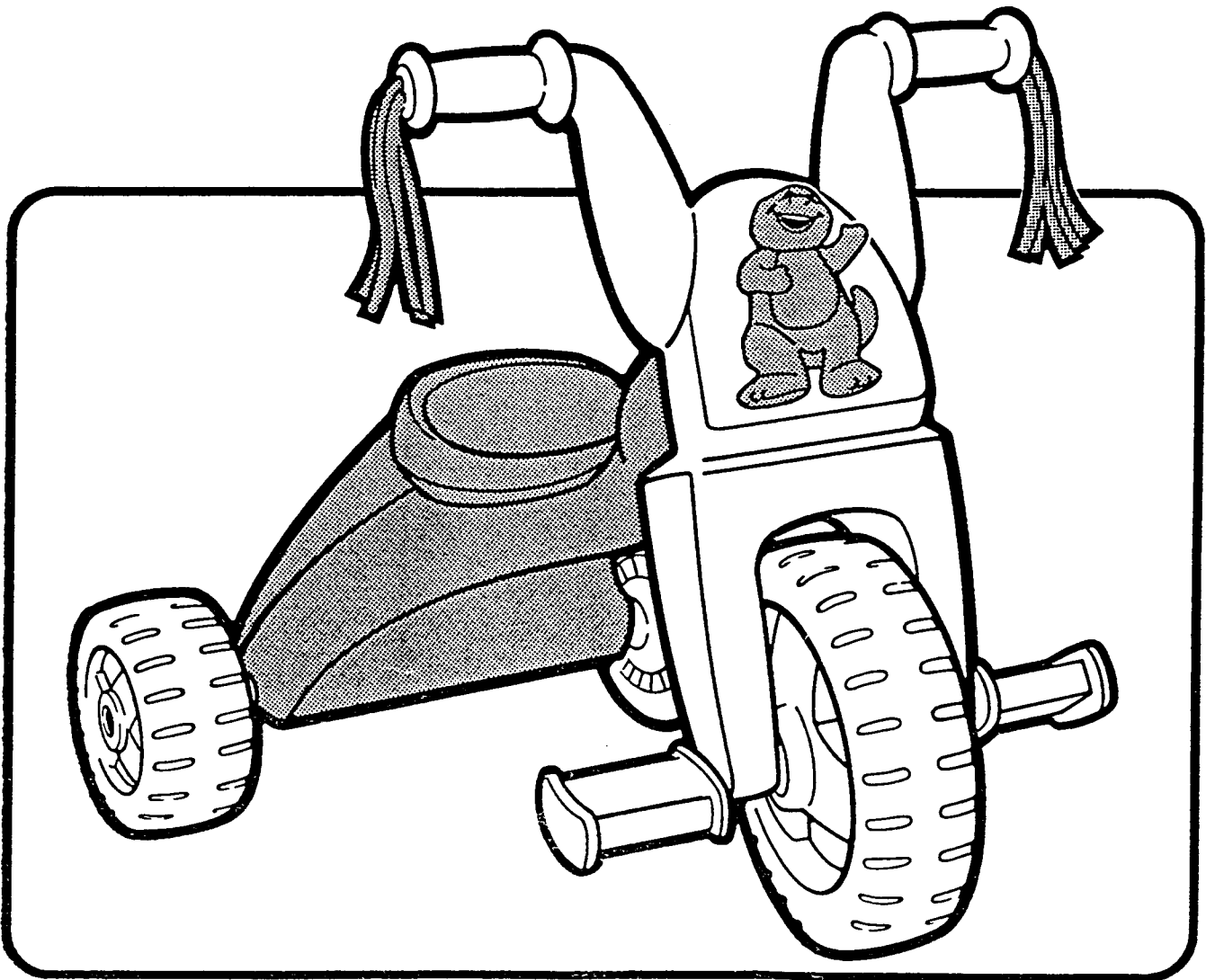

STEP 1. BODY & FORK/HANDLEBARS UNIT ASSEMBLY

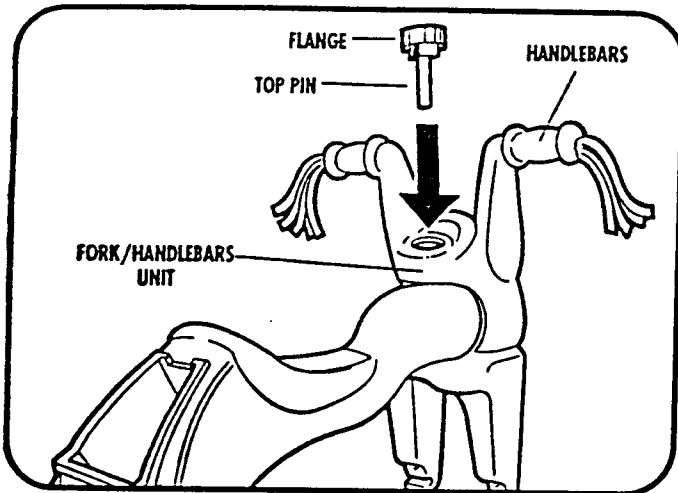

Insert front of body into center of fork/handlebars unit. Slide top pin through hole between handlebars and hole in body. Position flange on top pin so that it is flush against fork/handlebars unit.

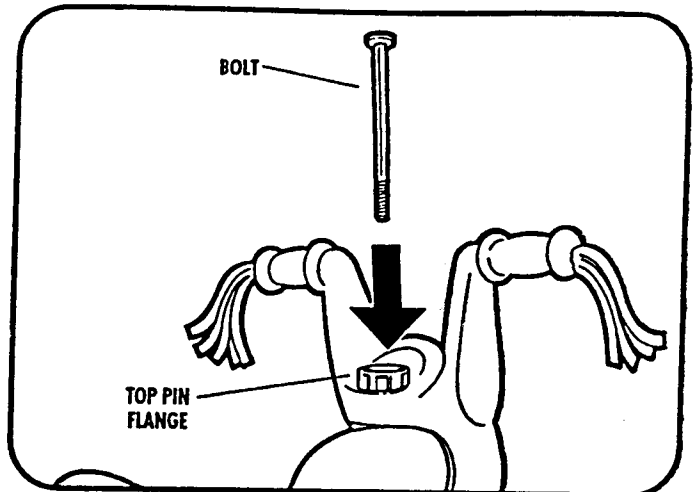

Slide bolt all the way into top pin as shown, so that head of bolt rests on base of top pin flange.

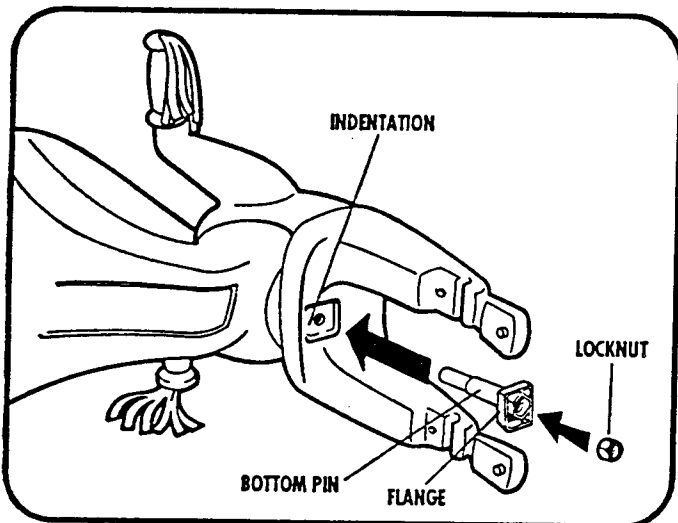

Turn assembly onto side. Be sure bolt extends through hole in underside of fork. Slide bottom pin over bolt and through hole in fork and hole in body. Fit flange on bottom pin into indentation on fork exactly as shown.

Fit locknut into recessed area on bottom pin flange. From top, tighten bolt firmly into locknut with regular screwdriver, holding locknut in place as you tighten. Check to ensure locknut is securely threaded onto bolt.

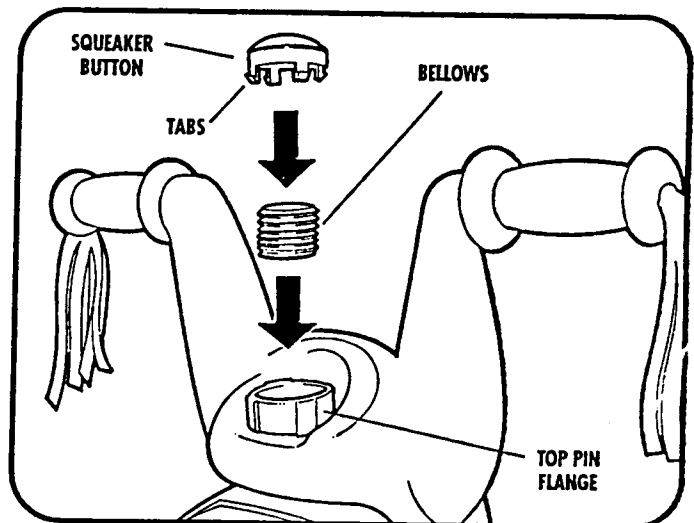

Place bellows inside top pin flange. Align tabs on squeaker button with slots on flange and snap button into flange.

STEP 2. FORK & WHEEL ASSEMBLY

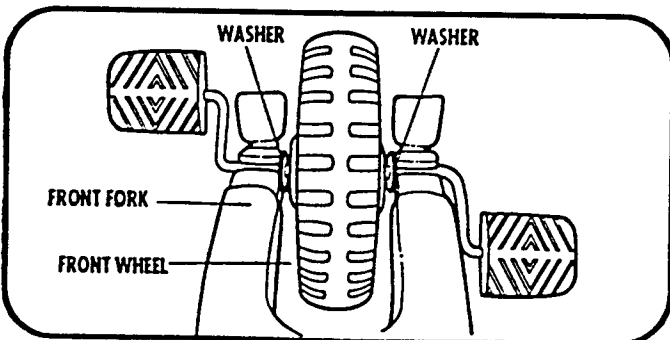

Turn vehicle upside down. Fit front wheel axle into grooves in front fork and hold in place. Be sure washers on axle are positioned between fork and wheel on each side.

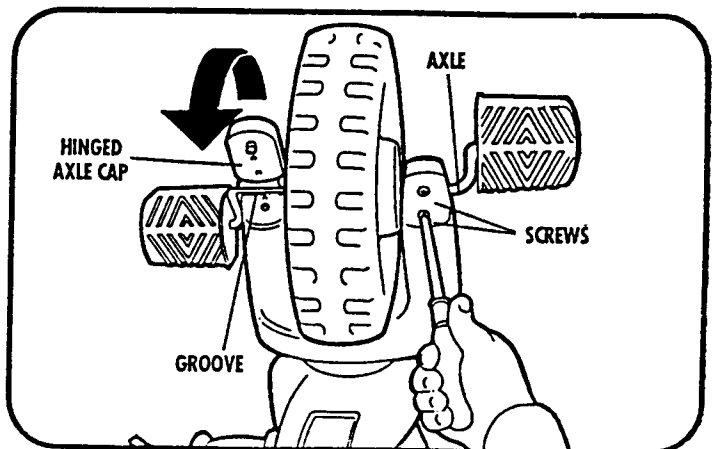

Swing hinged axle cap down and fit over one end of axle. Line up holes in axle cap with holes in fork. Fit 2 screws into holes in axle cap and tighten, using Phillips® screwdriver. DO NOT OVERTIGHTEN SCREWS. Repeat step on other side.

STEP 3. REAR WHEEL ASSEMBLY

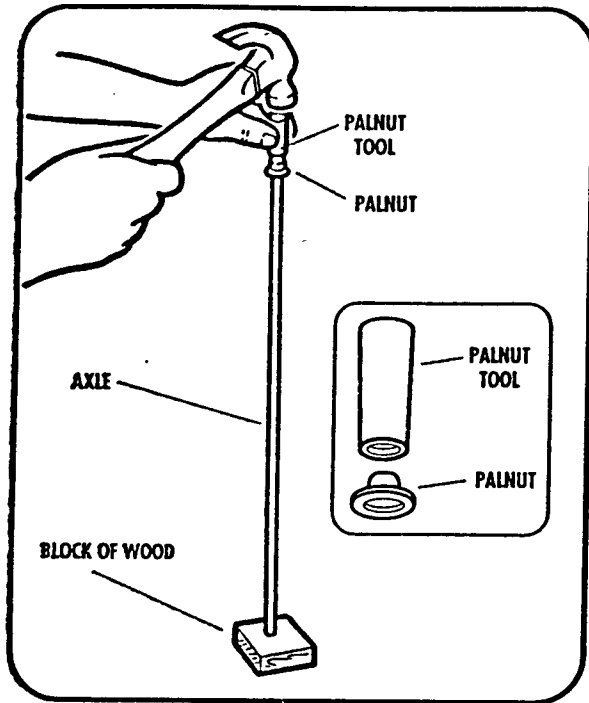

Place axle on small block of wood as shown. Position Palnut over top end of axle. Fit Palnut tool over Palnut. Using hammer, hit Palnut onto end of axle.

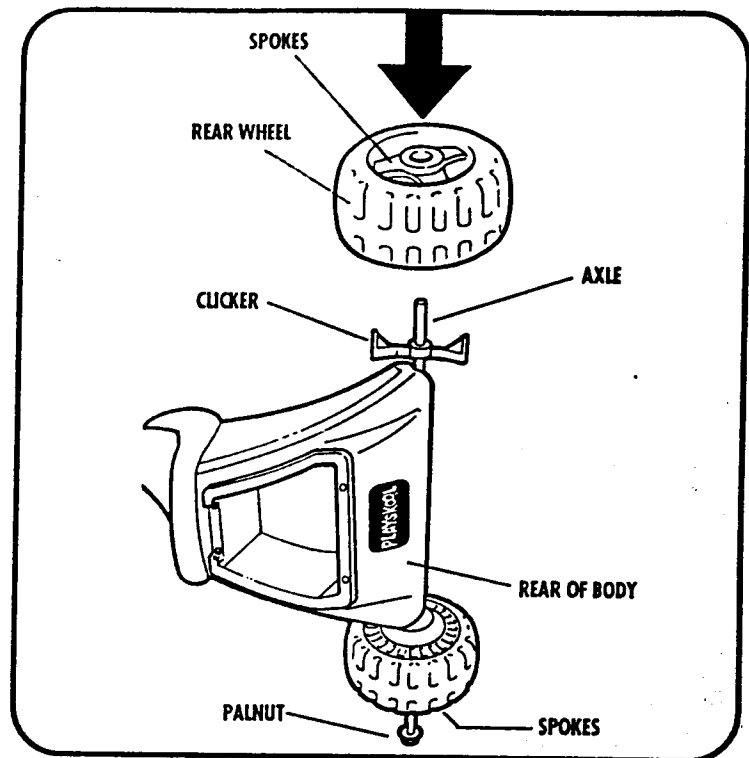

Slide axle through hole in spoked side of rear wheel. Slide axle through holes in rear of body. Slide clicker onto axle as shown. Slide other rear wheel over end of axle, so that spokes on wheel face out.

STEP 4. REAR WHEEL & BODY ASSEMBLY

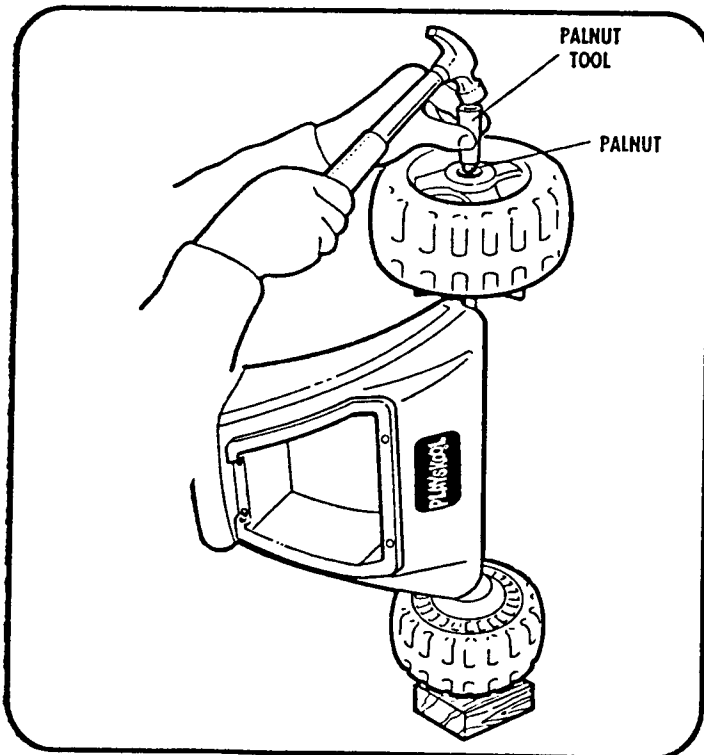

Stand body on its side, with open end of axle pointing up. Place block of wood under other end of axle.

If necessary, press down on top wheel so that open end of axle sticks through wheel. Position Palnut over open end of axle, and fit Palnut tool over Palnut. Using hammer, hit Palnut onto end of axle.

IMPORTANT: Test to be sure rear wheels are secure by tugging on them.

STEP 5. TRUNK DOOR ASSEMBLY

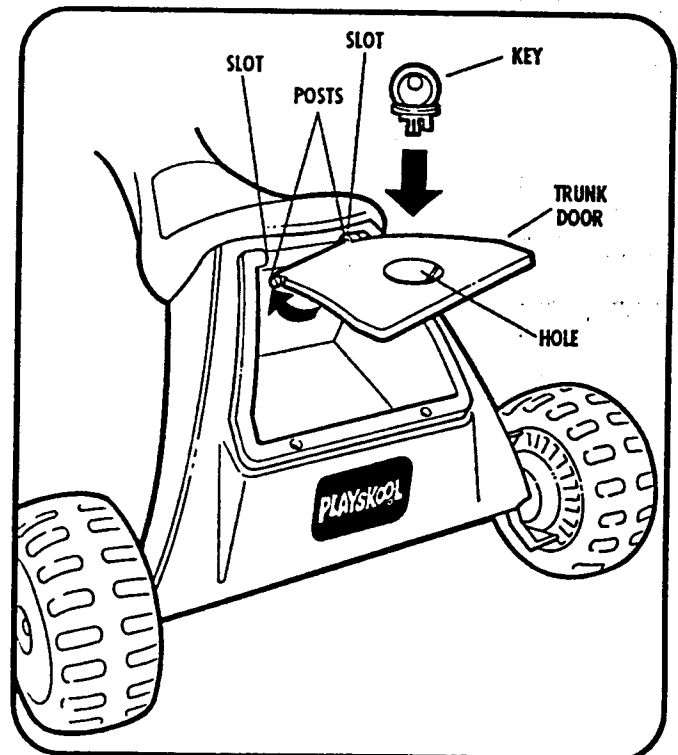

Insert posts on trunk door into slots on trunk as shown. Snap key into hole on trunk door.

**PARTS DIAGRAM for
BARNEY™ FUNTIME TRIKE™
Ride-on Model 50535**

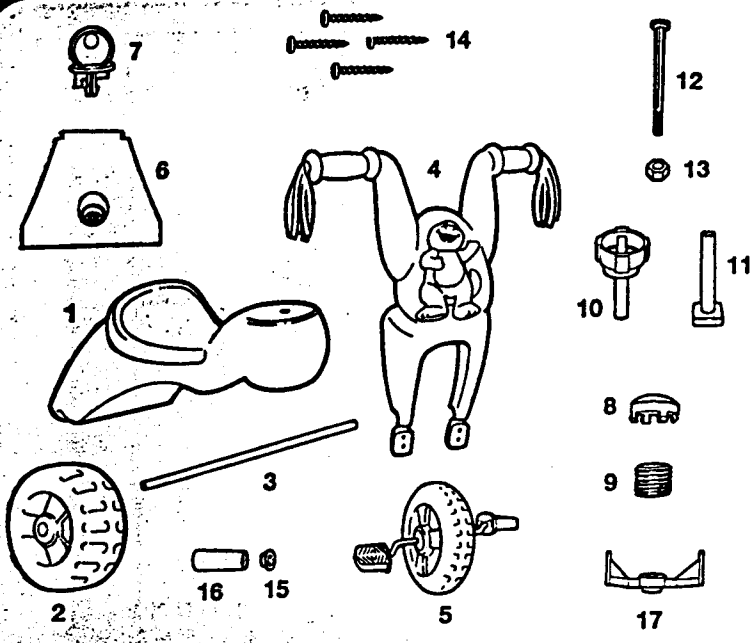

Please check all parts carefully before assembly.

- | | |
|--------------------------------------|----------------------------|
| 1. BODY | 10. TOP PIN |
| 2. REAR WHEELS (2) | 11. BOTTOM PIN |
| 3. REAR AXLE | 12. BOLT |
| 4. FORK/HANDLEBARS UNIT | 13. LOCKNUT |
| 5. FRONT WHEEL
(W/ AXLE & PEDALS) | 14. AXLE CAP
SCREWS (4) |
| 6. TRUNK DOOR | 15. PALNUTS (5) |
| 7. TRUNK KEY | 16. PALNUT TOOL |
| 8. SQUEAKER BUTTON | 17. CLICKER |
| 9. BELLOWS | |

If you have any questions, comments, or need additional information concerning this product or its parts, please call our Playskool Consumer Service hotline at 1-800-PLAYSKL (1-800-752-9755); Monday through Friday, 8:00 AM to 5:00 PM Eastern Time.
All written inquiries should be mailed to: Playskool Consumer Service Department, P.O. Box 200, Pawtucket, Rhode Island 02862-0200

ITEM NO.	DESCRIPTION	PART NO.
1	Body	44532900
2	1 Rear Wheel	44533100
3	1 Rear Axle	44534400
4	1 Fork/Handlebars Unit	44533000
5	Front Wheel with Axle & Pedals	44546900
6	Trunk Door	44820700
7	Trunk Key	44533700
8, 9	Squeaker Kit - Squeaker Horn, Bellows	Kit 94003
10	Top Pin	44533900
11	Bottom Pin	44757200
12, 13, 14	Hardware Bag - Bolt, Locknut, (4) Axle Cap Screws	Kit 94004
15, 16, 17	Palnut Bag - 5 Palnuts®, Palnut Tool, Clicker	Kit 249
18	Pedal Kit - 2 Pedals, 2 Palnuts & Palnut Tool	Kit 94002

AM 4 080

Palnut® is a registered trademark of TRW, Inc. All Rights Reserved.
© 1993 The Lyons Group. "Barney™" is a trademark of The Lyons Group.
© 1993 Playskool, Inc., Pawtucket, RI 02862 U.S.A., a subsidiary of Hasbro, Inc.
All Rights Reserved.
© denotes Reg. U.S. Pat. & TM Office.
MADE AND PRINTED IN U.S.A.
50535 P/N 44534800



Questions? Call: **1-800-PLAYSKL**™

For future reference, our toll-free consumer service number is also located on this product.