



⚠ WARNING:

**CHOKING HAZARD - Small parts.
Not for children under 3 years.**

AGES 4 AND UP

WARNING: Changes or modifications to this unit not expressly approved by the party responsible for compliance could void the user's authority to operate the equipment.

Batmobile[®] R/C Vehicle

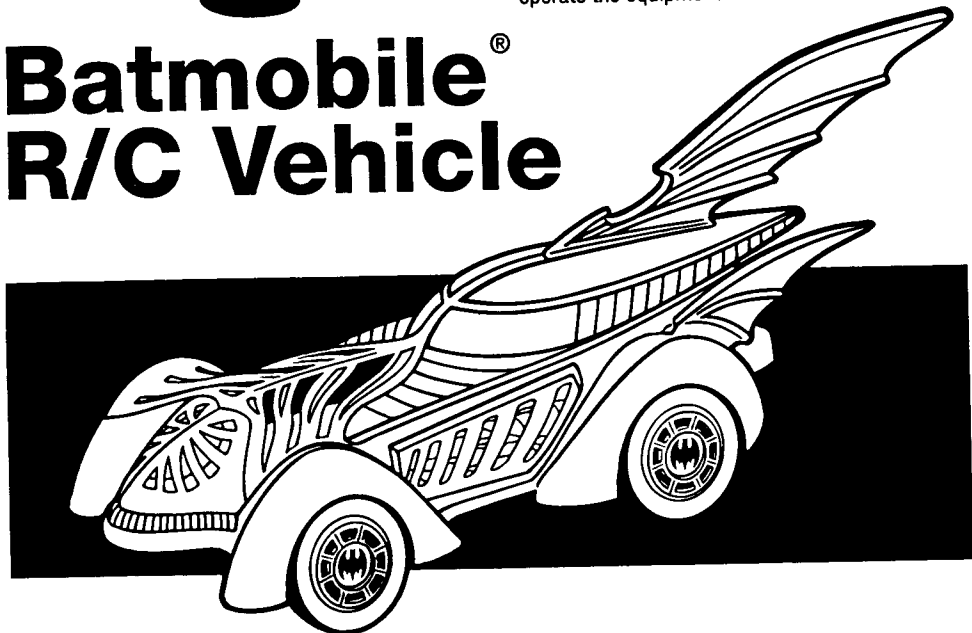

BATMAN[®] FOREVER

SAFETY PRECAUTIONS:

This vehicle is not recommended for children under the age of 4 years. Please read all of the instructions before operating this vehicle. Always follow general safety rules while operating vehicle: avoid hitting pets, furniture or people. Do not pick up vehicle while it is in motion. Keep hands, hair and clothing away from this vehicle when the power switch is turned to the "ON" position. Remove batteries when vehicle is stored. **Avoid tire contact on painted or varnished surfaces.** Recommend outdoor play with this vehicle.

CAUTION: TO AVOID BATTERY LEAKAGE

- 1) Be sure to insert the batteries correctly and always follow the toy and battery manufacturers' instructions;
- 2) Never mix old batteries with new batteries, or standard (carbon-zinc) with alkaline batteries;
- 3) Always remove exhausted or dead batteries from the product.

BATMAN and related elements are the property of DC Comics. TM & © 1995. All Rights Reserved.

520045.00

Kenner[®]

* ® & © 1995 TONKA CORPORATION,
a subsidiary of Hasbro, Inc.,
Pawtucket, Rhode Island 02862.
All Rights Reserved.

BATTERY REQUIREMENTS / INSTALLATION FOR VEHICLE

- Remove screw. Remove battery door from bottom of vehicle as shown.
- Install 4 "AA" Alkaline Batteries as shown. Replace door. Replace screw.
- Slide vehicle power switch ON.
- Now prepare transmitter for play.

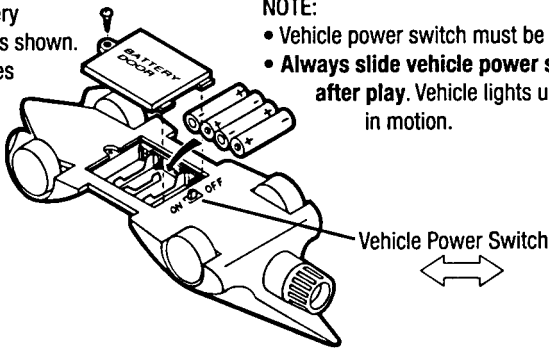

NOTE:

- Vehicle power switch must be ON to play.
- **Always slide vehicle power switch OFF after play.** Vehicle lights up only when in motion.

BATTERY REQUIREMENTS / INSTALLATION FOR TRANSMITTER

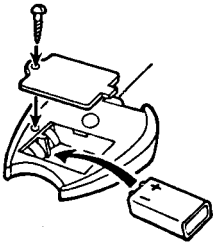

To operate your transmitter you will need a 9 Volt Alkaline Battery (sold separately).

- Remove battery cover as shown and install a new 9 Volt Alkaline Battery. Replace cover & screw.
- **PLEASE NOTE: Vehicle power switch must be in the ON position to receive commands from the transmitter.**

DIRECTION CONTROLS

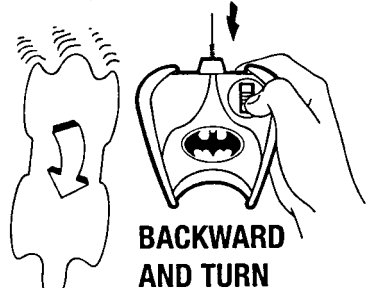
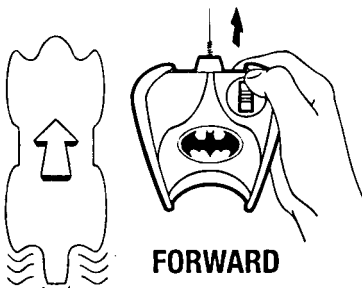

PROPER OPERATION AND STORAGE OF YOUR VEHICLE

1. **Best operation** of vehicle is on an OUT-OF-DOORS textured paved surface to avoid furniture damage and minimize noise level.
2. **Always** operate your vehicle within a range of 30 - 60 feet from you.
3. **Always** operate your vehicle on dry surfaces away from cars and other full-size vehicles.
4. **Always** store your vehicle in a cool, dry place and off of painted or varnished surfaces.
5. **Avoid** water or damp locations which may damage the vehicle's electronics. (If your vehicle ACCIDENTALLY gets wet and stops running, let it dry overnight before trying to run it again.)
6. **Avoid** operating around CB radios, baby monitors, cordless phones, electrical appliances, electric baseboard heaters, high voltage electrical wires and large, steel-reinforced concrete buildings all of which may cause interference.
7. **Avoid** running your vehicle and another vehicle on the same frequency.