

Assembly required. No tools needed.

⚠ WARNING: Do not use BEYBLADE® tops or BEYSTADIUM™ on tables or other elevated surfaces.

BEYBLADE tops/BEYSTADIUM are intended to be used on the floor. Do not lean over the stadium when BEYBLADE tops are in play. BEYBLADE tops may bounce up and hit eye or face.



- Before assembly and playing, please read instructions. Please keep these instructions for future reference.
- When removing parts from runner frame, ask an adult to help you trim off any excess plastic using scissors or other suitable tool.
- The frame is numbered. Please follow the numbers carefully and make sure you are assembling the right parts.
- Discard plastic bags immediately.

PARTS:

Runner Parts, Attack Ring, Weight Disk, Blade Base, Left Spin ENGINE GEAR™*, Left Spin Launcher, Ripcord, TURBO WINDER™*, Decals.

BEYSTADIUM sold separately.

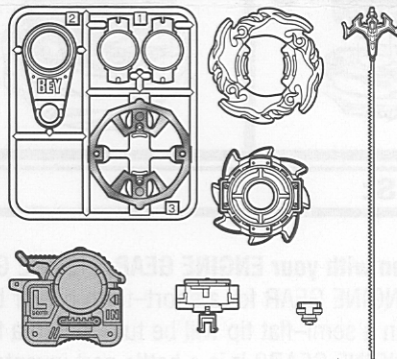

BUILD:

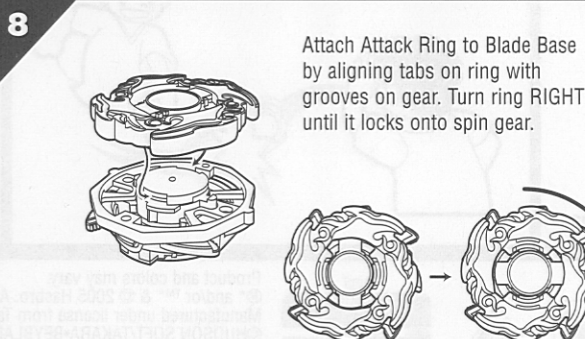
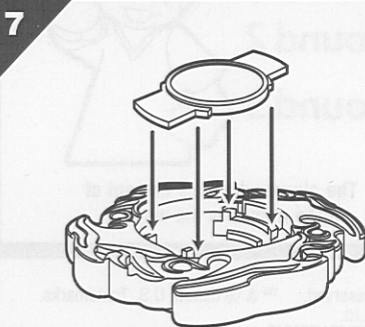
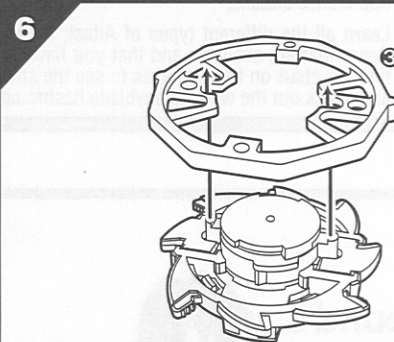
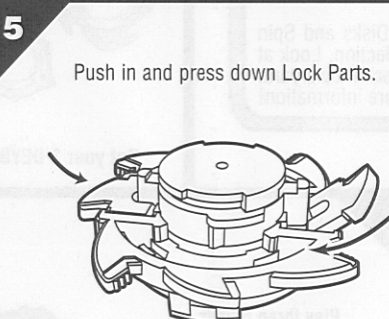
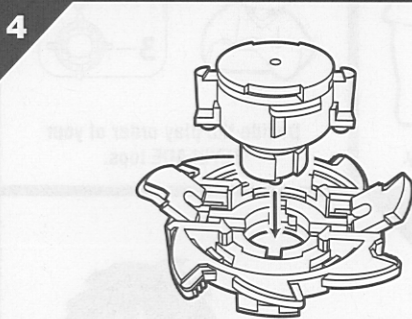
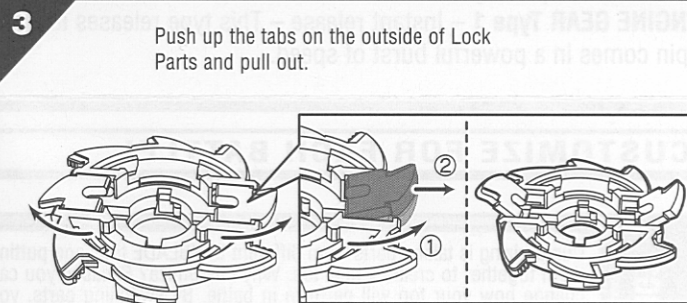
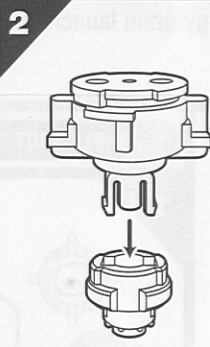
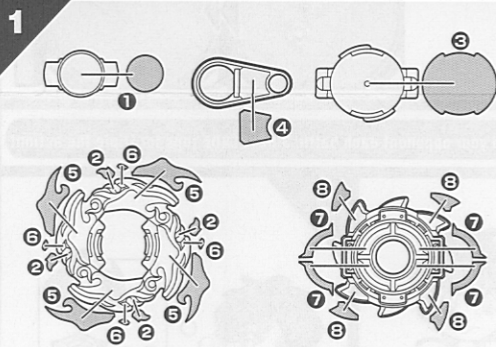

BEFORE LAUNCH:

Use TURBO WINDER™* to crank the ENGINE GEAR™* tip counter-clockwise until it clicks.

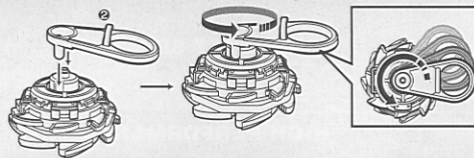

LAUNCH:

A

Insert ripcord into launcher as shown.

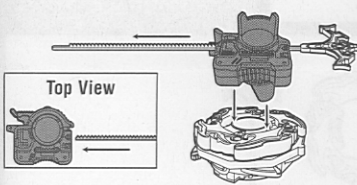

B

Insert posts on launcher into openings in BEYBLADE®* top, as shown.

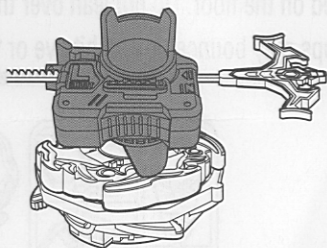

C

Hold lower half of launcher and rotate BEYBLADE top right to lock it in place.

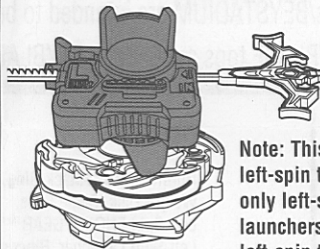

Note: This is a left-spin top. Use only left-spin launchers with left-spin tops.

D

Holding the launcher securely, pull the ripcord over the BEYSTADIUM™ (not included) – the BEYBLADE top will spin... launch... and battle!

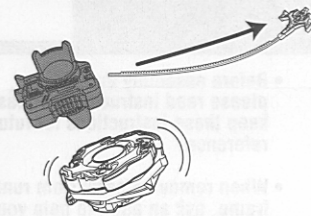

FEATURES:

Greater acceleration with your ENGINE GEAR: ENGINE GEAR tops are equipped with an ENGINE GEAR for a short-term power blast. When the engine kicks in, even a semi-flat tip will be turned into a tip boasting super mobility. What is ENGINE GEAR? It is a battle part invented to improve the battle potential of your BEYBLADE. The rotational forces of the BEYBLADE and the engine combine to improve your BEYBLADE with super acceleration performance!

ENGINE GEAR Type 1 – Instant release – This type releases its spin energy upon launch. The spin comes in a powerful burst of speed.

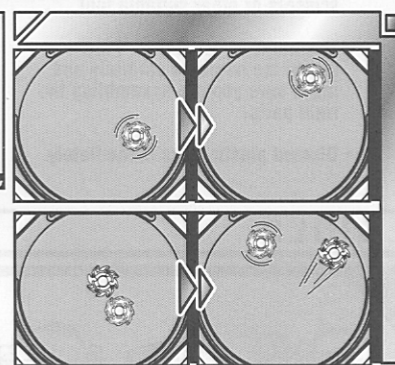
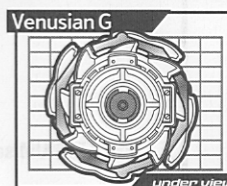

CUSTOMIZE FOR EACH BATTLE!

WHAT IS CUSTOMIZING?

Customizing is taking parts from different BEYBLADE tops and putting them together to create a new top. Why customize? Because you can change how your top will perform in battle. By switching parts, you can create a top that will perform a certain way. For example, if your opponent has an Attack Type top, you may want to change your top's parts to make it a Defense Type top, to help withstand your opponent's attacks.

Learn all the different types of Attack Rings, Weight Disks and Spin Gears that are available and that you have in your collection. Look at the star chart on the packages to see the strengths of each top's parts and check out the website beyblade.hasbro.com for more information!

TRIPLE SHOT You and your opponent each battle 3 BEYBLADE tops for triple the action!

1

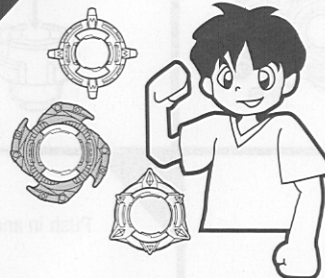

Get your 3 BEYBLADE tops ready.

2

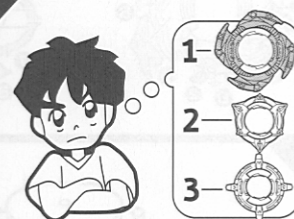

Decide the play order of your BEYBLADE tops.

3

► Round 1
Round 2
Round 3

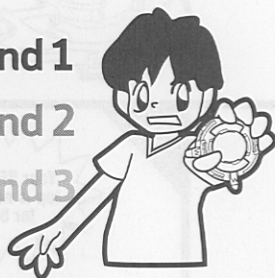

To start the game, players launch their first BEYBLADE top.

4

Play three rounds.

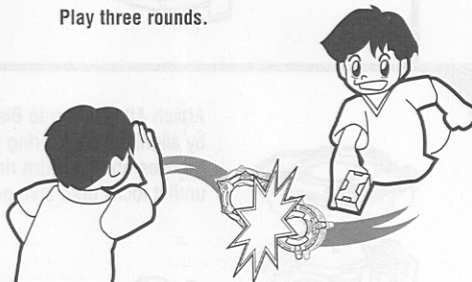

5

► Round 1
► Round 2
► Round 3



The player who wins two out of three rounds is the winner!

Check it out! For game ideas, strategies and official game rules, please see



d-rights

www.beyblade.com
beyblade.hasbro.com



Product and colors may vary.
©* and/or ™* & © 2005 Hasbro. All Rights Reserved. ™ & © denote U.S. Trademarks.
Manufactured under license from Takara Co., Ltd.
©HUDSON SOFT/TAKARA•BEYBLADE PROJECT•TV TOKYO
©Aoki Takao•BB3Project•TV Tokyo Licensed by d-rights Inc.
TM and ©Disney, TM & ©ABC Family

P/N 6480450000