



HIGH PERFORMANCE TOPS
COMPETITIVE GRADE

AGE 8+
82585/82500 Asst.

Wolborg 2™

A-39

Endurance/Defense Type

⚠ WARNING: Do not use BEYBLADE tops or Beystadium™ on tables or other elevated surfaces.

BEYBLADE tops/BEYSTADIUM are intended to be used on the floor. Do not lean over the stadium when BEYBLADE tops are in play. BEYBLADE tops may bounce up and hit eye or face.

Assembly required.
No tools needed.

Includes unassembled BEYBLADE top, launcher and ripcord.

- Before assembly and playing, please read instructions. Please keep these instructions for future reference.
- When removing parts from runner frame, ask an adult to help you trim off any excess plastic using scissors or other suitable tool.
- The frame is numbered. Please follow the numbers carefully and make sure you are assembling the right parts.
- Discard plastic bags immediately.

PARTS:
Runner Frame Parts,
Blade Base, Attack Ring,
Weight Disk, Bearing,
Inner Shaft, Launcher,
Ripcord

BEYSTADIUM sold separately.

Note: Bit Chips with holes and/or triangle on one side can be used with BEYBLADE Electronic Launcher (sold separately).

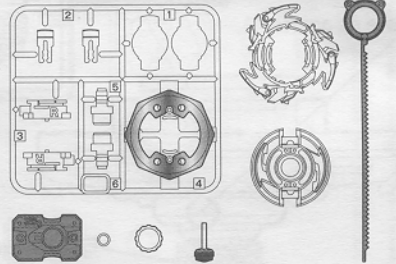

BUILD:

1 Peel and apply stickers as shown.

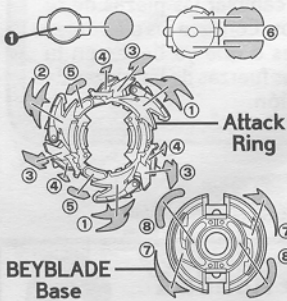

2

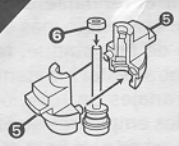

Slide Bearing (6) onto Inner Shaft. Snap Outer Shaft (5) around Inner Shaft.

3



Place Metal Weight Gear on Shaft assembly.

4

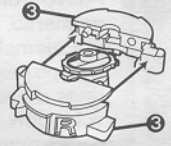

Snap both halves of Right Spin Gear (3) around Shaft assembly. Make sure Metal Weight Gear and Shaft are in grooves.

5

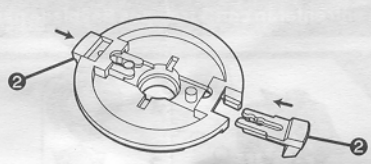

Insert Attachments (2) into Blade Base until the tips are just past the knobs. Do not insert attachments all the way in at this time.

6

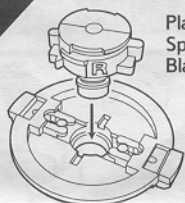

Place Right Spin Gear into Blade Base.

7



Snap Attachments (2) all the way into Blade Base to secure Right Spin Gear.

9

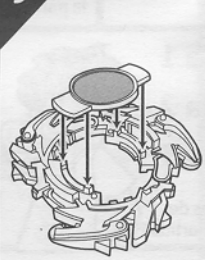

Attach Bit Chip to Attack Ring.

10

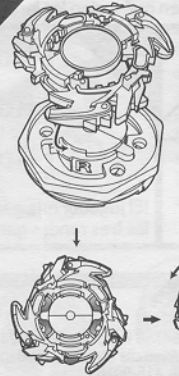

Attach Attack Ring to base, aligning tabs on ring with grooves on gear. Turn Attack Ring LEFT until it locks onto spin gear. (To remove ring from gear, turn ring right.)

LEFT TO LOCK.

11

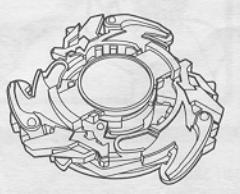

LAUNCH:

A Insert ripcord into launcher as shown.

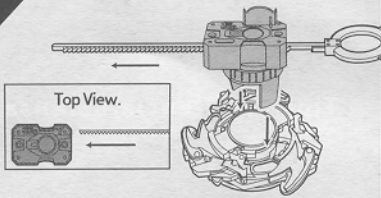

NOTE: Use left-spin launchers for Left Spin Gears; use right-spin launchers for Right Spin Gears.

B Insert posts on launcher into openings in BEYBLADE top, as shown.

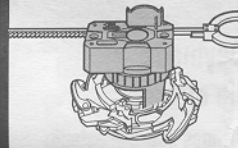

C Hold lower half of launcher and rotate BEYBLADE top left to lock it in place.

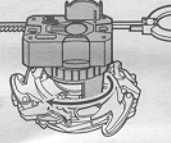

D



Holding the launcher securely, pull the ripcord over the BEYSTADIUM (not included) – the BEYBLADE top will spin... launch... and battle!

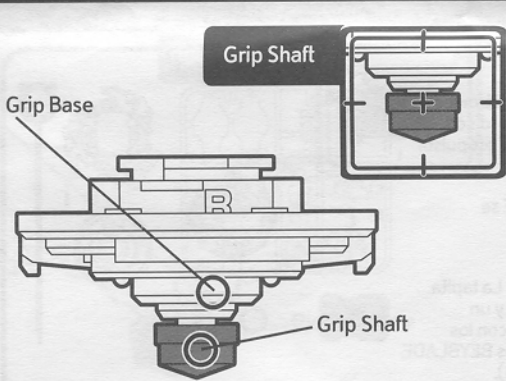

The tip of the shaft grips the surface of the stadium, making it less likely for the BEYBLADE to spin out of the stadium when two BEYBLADE tops collide!!

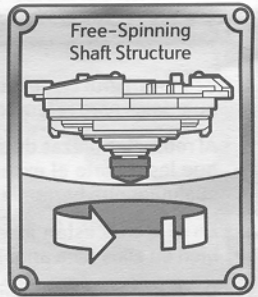

High-Performance Free-Spinning Bearing
This bearing allows the shaft to spin.

CUSTOMIZE FOR EACH BATTLE!

WHAT IS CUSTOMIZING?

Customizing is taking parts from different BEYBLADE tops and putting them together to create a new top. Why customize? Because you can change how your top will perform in battle. By switching parts, you can create a top that will perform a certain way. For example, if your opponent has an Attack Type top, you may want to change your top's parts to make it a Defense Type top, to help withstand your opponent's attacks.

Learn all the different types of Attack Rings, Weight Disks and Spin Gears that are available and that you have in your collection. Look at the star chart on the packages to see the strengths of each top's parts and check out the website beyblade.hasbro.com for more information!

TRIPLE SHOT You and your opponent each battle 3 BEYBLADE tops for triple the action!

1

Get your 3 BEYBLADE tops ready.

2

Decide the play order of your BEYBLADE tops.

3

▶ Round 1
Round 2
Round 3

To start the game, players launch their first BEYBLADE top.

4

Play three rounds.

5

▶ Round 1
▶ Round 2
▶ Round 3

The player who wins two out of three rounds is the winner!

Check it out!

For game ideas, strategies and official game rules, please see

BEYBLADE.COM
BEYBLADE.HASBRO.COM



Product and colors may vary. / Le produit et les couleurs peuvent varier.
 ® and/or TM* & © 2002 Hasbro.
 All Rights Reserved. © denotes Reg. U.S. Pat. & Manufactured under license from Takara Co., Ltd.
 © HUDSON SOFT/TAKARA-BEYBLADE PROJECT
 TM & © ABC Family Worldwide, Inc. All Rights Reserved.