

33510

**Cabbage Patch Kids**  
**Freewheeler™**  
**ASSEMBLY INSTRUCTIONS**

DOLL NOT INCLUDED

**PLEASE RETAIN THIS GUIDE AND ALL LITERATURE FOR FUTURE REFERENCE.**

**TOOLS REQUIRED:** hammer, Phillips® screwdriver and small block of wood.

**CAUTION:** TOY ONLY—NOT TO BE USED FOR TRANSPORTING INFANTS OR CHILDREN.

CYCLE SEATS ALL CABBAGE PATCH KIDS®, BUT ONLY 16" KIDS™ ARE LONG ENOUGH FOR THEIR FEET TO BE SECURED TO THE PEDALS.

**PLEASE NOTE**

ADULT ASSEMBLY IS REQUIRED. READ INSTRUCTIONS PRIOR TO ASSEMBLY. PERIODICALLY CHECK TO ENSURE ALL PARTS AND HARDWARE ARE SECURE. NOTE: PAINTED SURFACES, DECALS AND LABELS ARE NON-TOXIC.

Before you start assembly, check all parts. Refer to illustrated parts list.

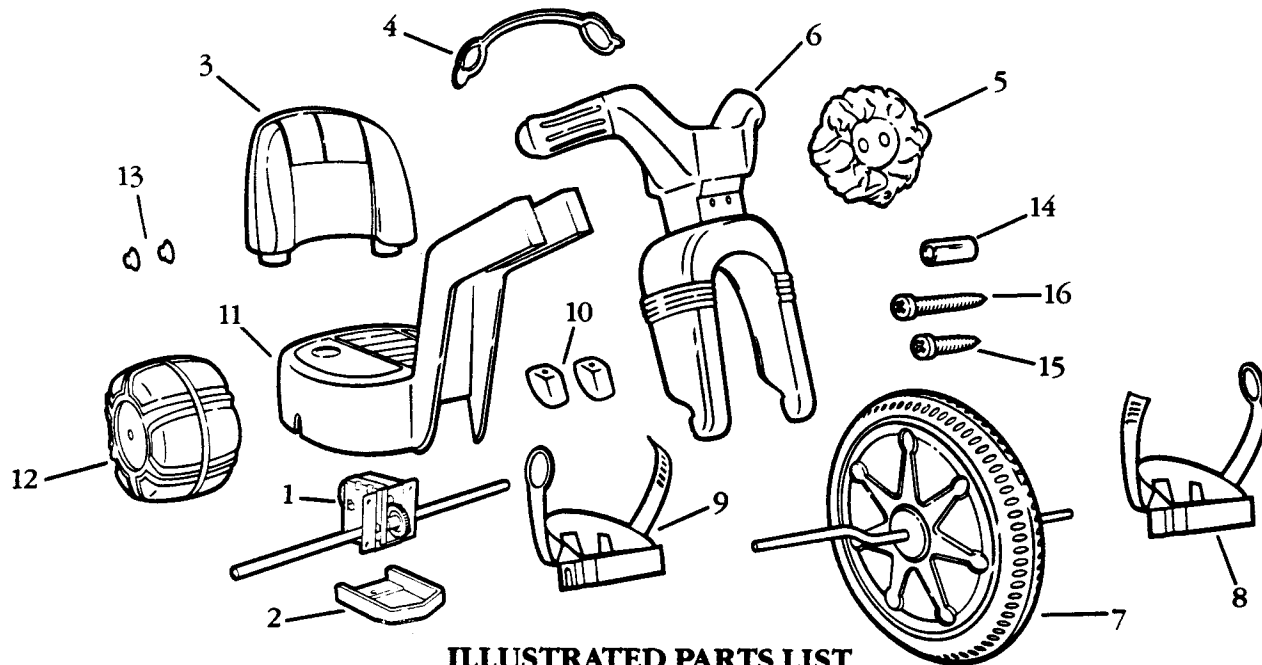

**ILLUSTRATED PARTS LIST**

- |                              |                                 |
|------------------------------|---------------------------------|
| 1. DRIVE MECHANISM (1)       | 10. AXLE CAPS (2)               |
| 2. DRIVE MECHANISM COVER (1) | 11. BODY (1)                    |
| 3. SEAT BACK (1)             | 12. REAR WHEELS (2)             |
| 4. HANDSTRAPS (2)            | 13. PALNUT® (2)                 |
| 5. PLAQUE (1)                | 14. PALNUT TOOL (1)             |
| 6. HANDLEBAR/FORK (1)        | 15. 1/2" SCREW (4)              |
| 7. FRONT WHEEL W/CRANK (1)   | 16. 1" SCREW (5)                |
| 8. LEFT PEDAL W/STRAPS (1)   | 17. DECAL SHEET (1) (not shown) |
| 9. RIGHT PEDAL W/STRAPS (1)  |                                 |

Palnut® is a registered trademark of TRW, Inc. All Rights Reserved.

**NOTE: REFER TO GAUGE AT END OF STEP 8 FOR PROPER SCREW LENGTH.**

## STEP 1. INSTALL SEAT BACK

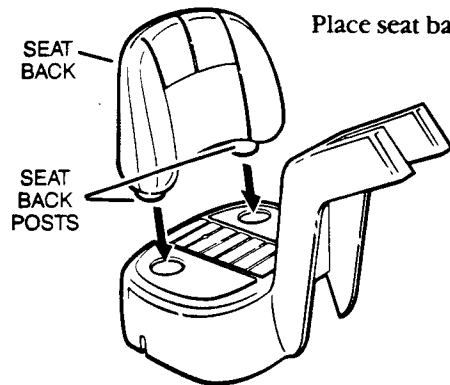

Place seat back posts in body holes.

From underside of body, secure seat back in place by first tightening a 1" screw in the center hole between the two posts. Hold seat back tightly to body when securing screw. Then, insert and tighten (2) 1" screws into post holes located on each side of the center screw. Note: Because there are no pilot holes, additional force will be required when tightening screws. **DO NOT OVERTIGHTEN.**

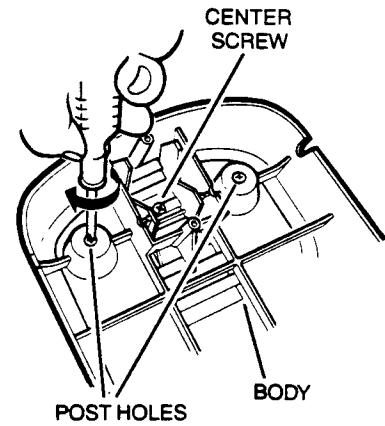

## STEP 2. INSTALL DRIVE MECHANISM

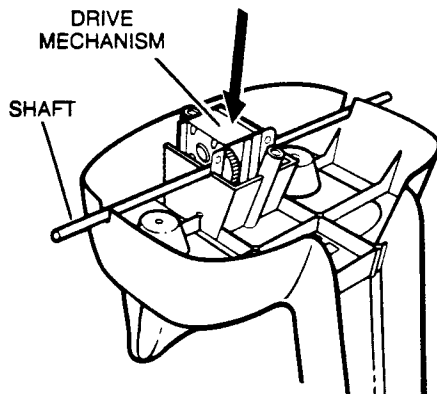

Press drive mechanism into underside of body as shown, making sure that shafts on both sides of mechanism protrude from notches on body.

Secure drive mechanism to body by placing mechanism cover over drive mechanism and tightening two 1/2" screws into holes in cover and body.

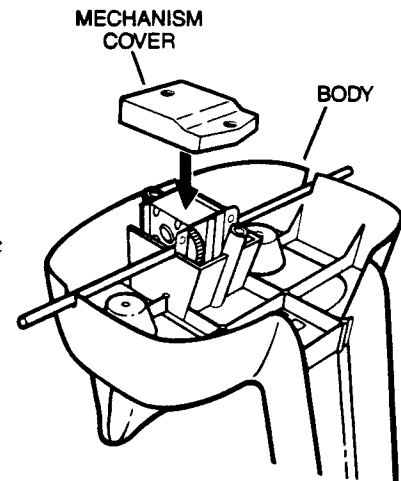

## STEP 3. FASTEN REAR WHEELS

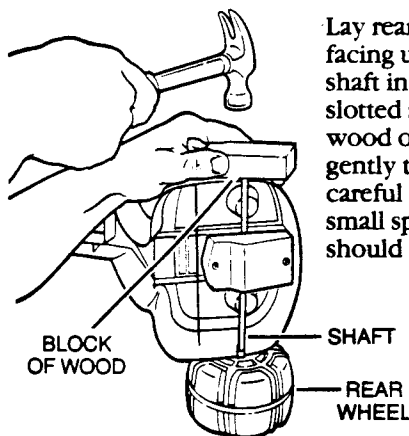

Lay rear wheel onto flat surface, hole in wheel facing up. Turn body onto its side, and slide shaft into hole in wheel (tabs on shaft into slotted areas of hole). Place a small block of wood on top of other shaft and, with a hammer, gently tap the first shaft into the wheel hole. (Be careful not to tap shaft into hole too far - a small space between wheel and body should remain.)

Flip body onto other side and repeat process for other wheel, this time placing block of wood onto wheel already attached.

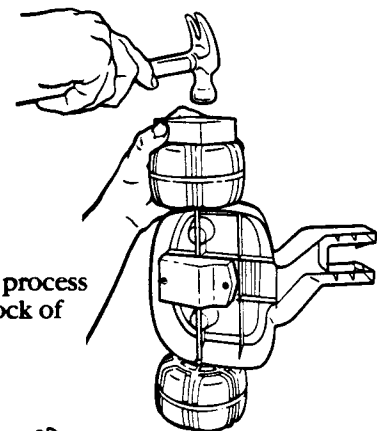

## STEP 4. FASTEN PEDALS TO CRANKSHAFT

**IMPORTANT: THE PEDALS ARE LEFT AND RIGHT. EACH PEDAL MUST BE PLACED ON CRANKSHAFT WITH PALNUT RETAINER AND SOLID OVAL END OF STRAP FACING OUTWARD AS SHOWN.**

Place one end of front wheel crankshaft on small block of wood as shown. Place a palnut into palnut retainer on outside end of pedal. Slide pedal down crankshaft. Position palnut on shaft end and gently tap palnut with hammer until seated. Make sure the palnut is secure by gently pulling on the pedal.

Turn front wheel over and attach remaining pedal in the same manner.

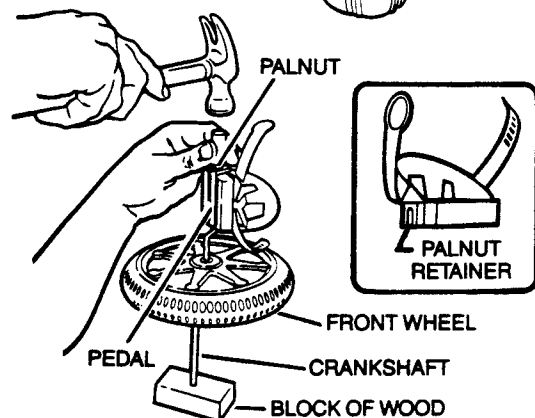

## STEP 5. ASSEMBLE FRONT WHEEL TO FORK

Place the assembled front wheel into fork by positioning the crankshaft into slots of the fork as shown.

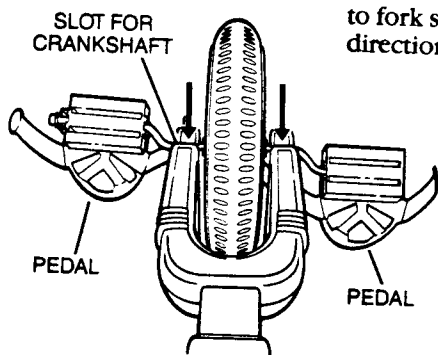

NOTE: BE SURE that front wheel is assembled to fork so that pedal straps face the proper direction as shown.

Position an axle cap over the crankshaft as shown. Using a Phillips® screwdriver, secure axle cap to fork by attaching and tightening a 1/2" screw. Attach the other axle cap in the same manner.

NOTE: Do not use excessive force when tightening the screws. DO NOT OVERTIGHTEN.

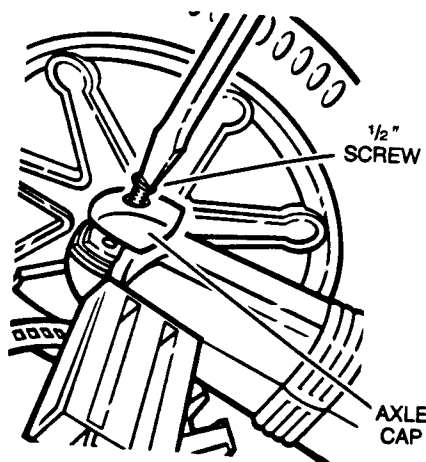

## STEP 6. ATTACH FORK AND WHEEL ASSEMBLY TO BODY

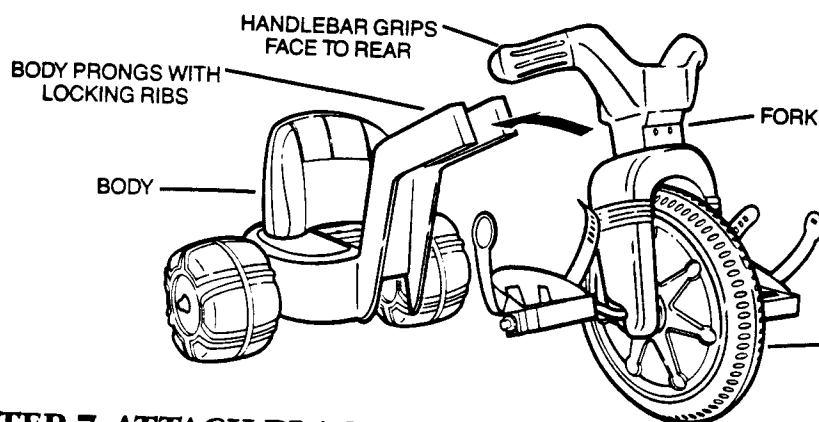

Insert the fork into neck of body as shown. The fork will lock in place behind locking ribs. The locking ribs may be slightly spread apart by hand to ease insertion of the fork.

## STEP 7. ATTACH PLAQUE

Fit the plaque completely over the front of the neck with hole facing down. Using a Phillips® screwdriver, attach and tighten two 1" screws as shown. Do not use excessive force when tightening the screws. DO NOT OVERTIGHTEN.

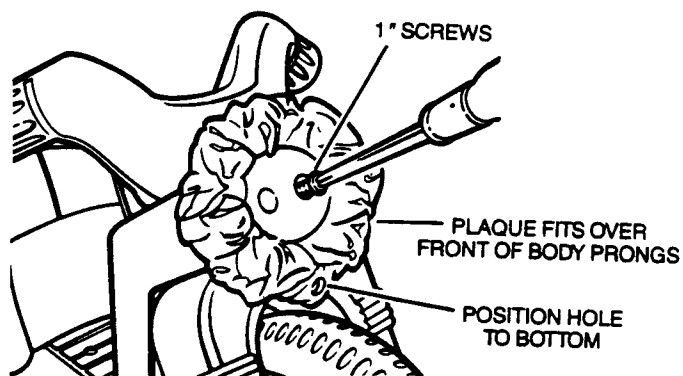

## STEP 8. ATTACH HAND STRAPS

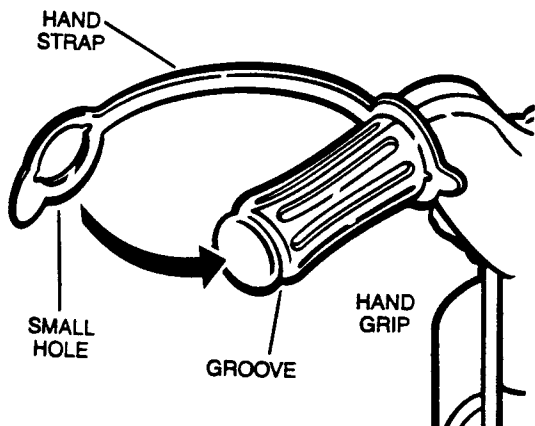

Slide end of handstrap with large hole up to forward groove of handgrip. (Use the handstrap tab to get a good grip - this will be a tight fit and may require extra force.) Fit end of strap with small hole into rear groove as shown. Repeat for other handstrap and handgrip.

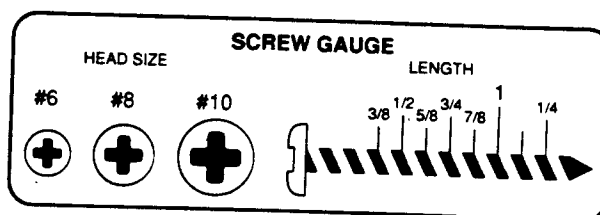

## STEP 9. APPLY DECALS

**CAUTION:** DECALS HAVE QUICK-SETTING ADHESIVE. BE SURE OF POSITION BEFORE APPLYING. DECAL CANNOT BE LIFTED AFTER SETTING.

**NOTE:** Thoroughly wipe decal areas with clean, dry cloth before applying decals.

Using decal sheet, remove decals one at a time and apply to appropriate positions as shown. Make sure all decals are positioned as indicated.

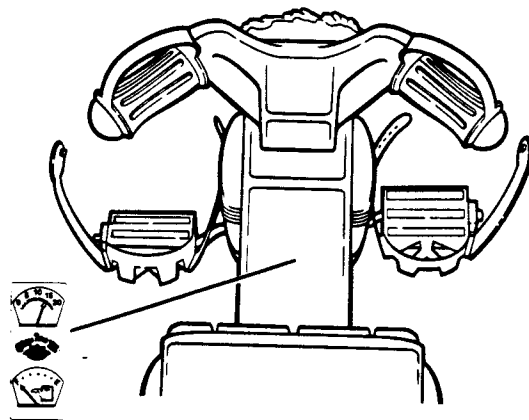
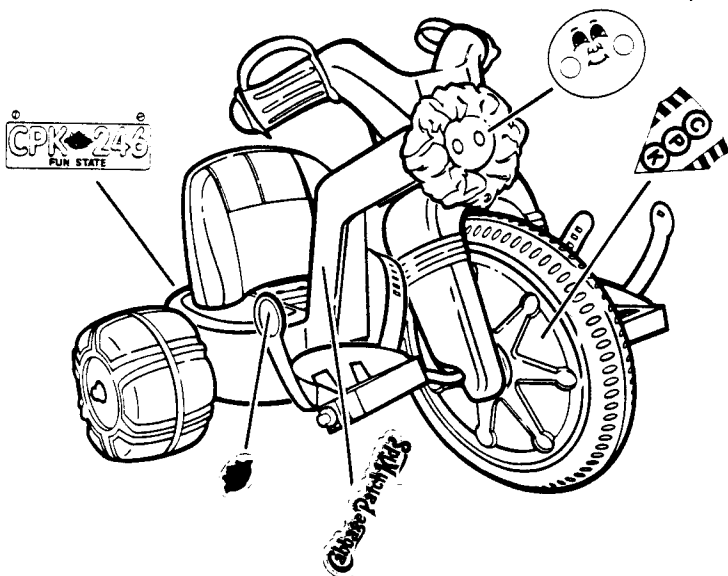

**NOTE:** PAINTED SURFACES, DECALS AND LABELS ARE NON-TOXIC.

## STEP 10. PLACE YOUR 'KID™ ON FREEWHEELER™

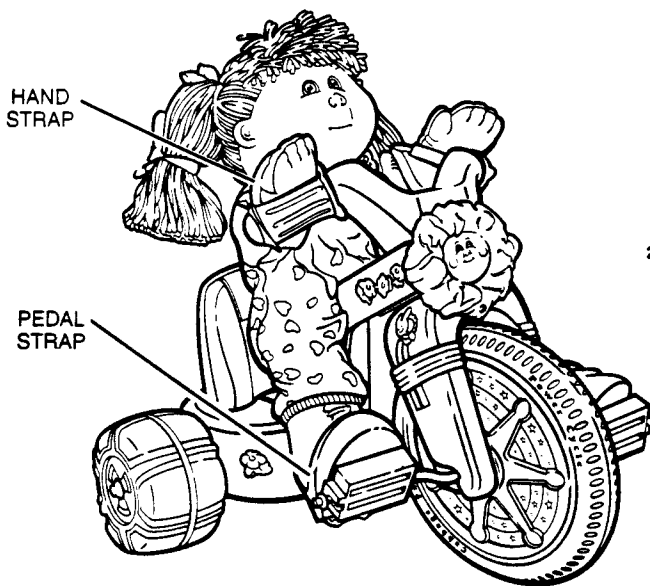

Seat your CABBAGE PATCH KID® on the Freewheeler™. Slip each hand through loop of handstrap up to doll's wrist as shown.

If your KID™ is less than 16" tall, you can start the fun rolling now (your doll's feet aren't long enough to be secured to the pedals). Find an open area, give the cycle a push and watch it go, go, GO!

If your KID™ is 16" tall, place each foot in a pedal and secure by attaching pedal straps. Now you're ready to go! Find an open area, then push the cycle and watch as your KID™ "pedals" away!

If you have any questions, comments, or need additional information concerning this product or its parts, please call Hasbro Consumer Service at 1-401-431-8697, Monday through Friday, 8:00 AM to 5:00 PM Eastern Time.

All written inquiries should be mailed to:

Hasbro Consumer Service Department  
P.O. Box 200  
Pawtucket, Rhode Island 02862-0200

©Copyright 1991, ORIGINAL APPALACHIAN ARTWORKS, INC. ALL RIGHTS RESERVED.  
MADE UNDER LICENSE FROM ORIGINAL APPALACHIAN ARTWORKS, INC.  
Manufactured for Hasbro, Inc., Pawtucket, RI 02862 U.S.A. **MADE IN U.S.A.**

P/N 42085100