

FIREBALL ISLAND[®]

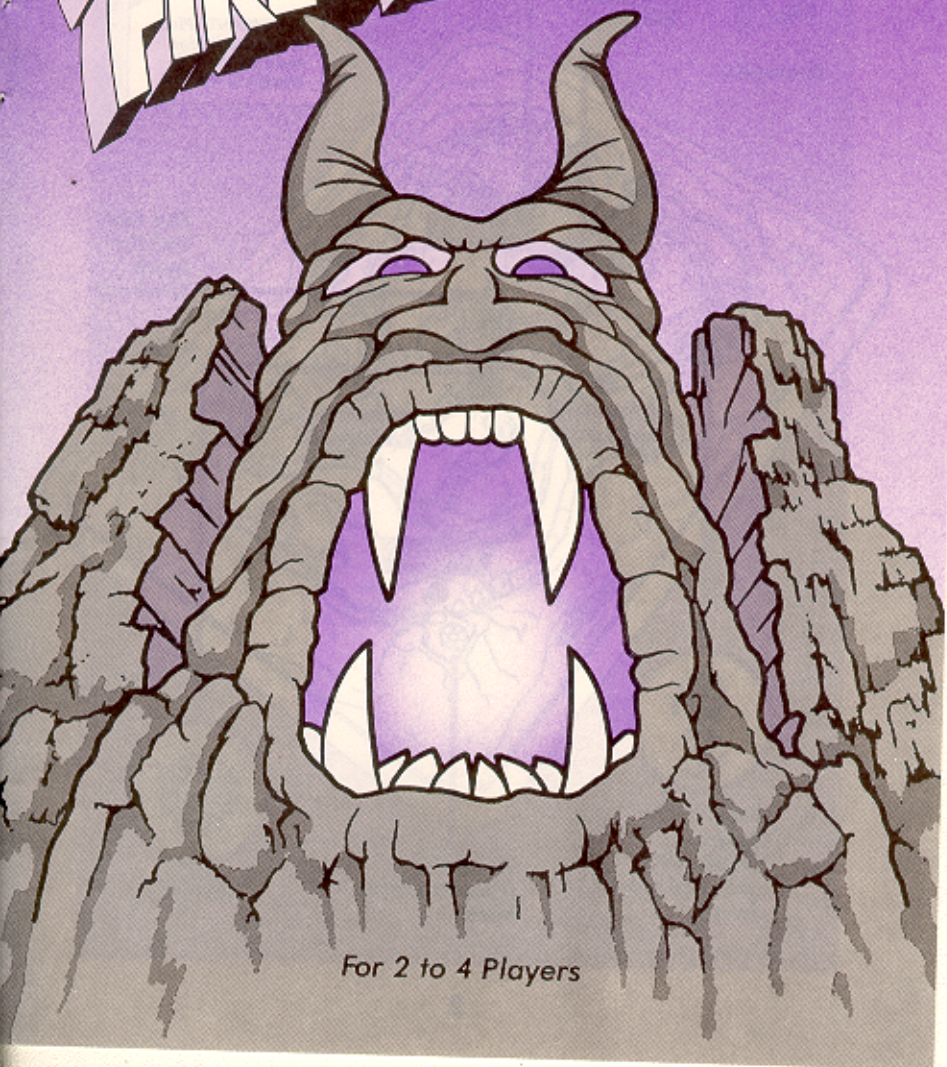

For 2 to 4 Players

FIGURE 1: Gameboard Setup

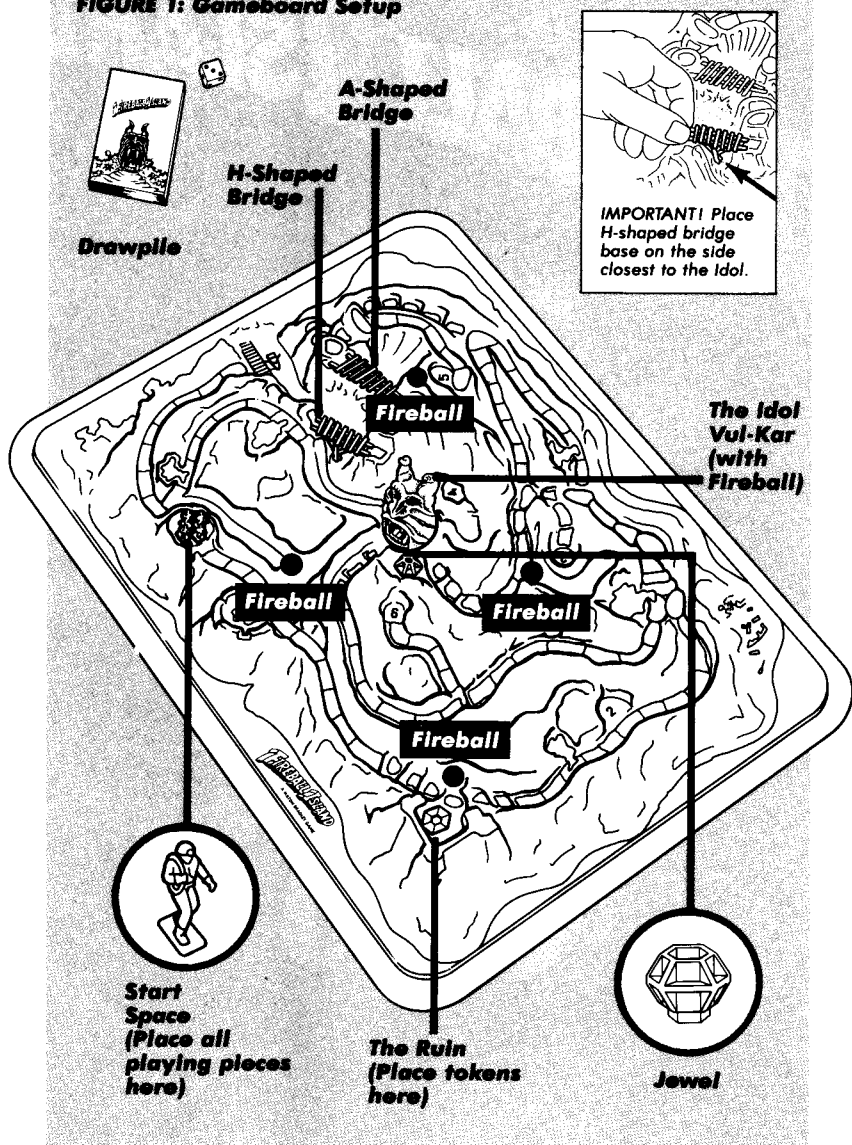

OBJECT

Capture the jewel, and be first to reach the Dock with it.

CONTENTS

- | | |
|--------------------------|------------------------|
| 1 gameboard | 4 plastic tokens |
| 4 plastic playing pieces | 5 red Fireball marbles |
| 1 three-piece Idol | 1 red jewel |
| 2 two-piece bridges | 1 die |
| 1 deck of 48 cards | 1 rulebook |

GAME SETUP

1. Set the gameboard on a flat level surface. Figure 1 shows the gameboard set up and ready for play. Refer to it for parts placement as you read the setup steps below.
2. Carefully break the plastic parts off the runner.
3. IDOL ASSEMBLY. Assemble the Idol as shown in Figure 2. Then place the Idol on the gameboard.

FIGURE 2
Assembling
the Idol

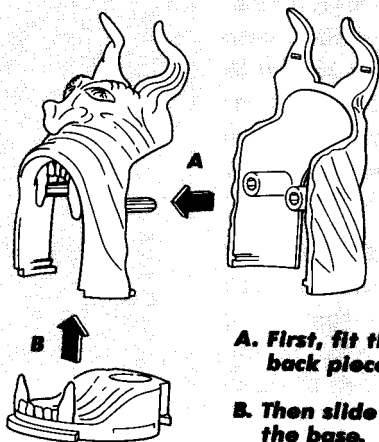

- A. First, fit the front and back pieces together.
- B. Then slide the top onto the base.

4. **BRIDGE ASSEMBLY.** Assemble the two bridges as shown in Figures 3A and 3B. Then place them on the gameboard.

FIGURE 3A

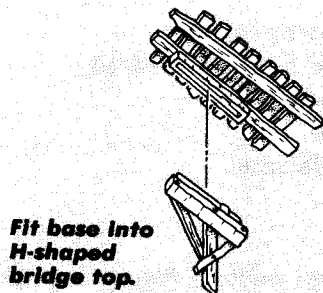
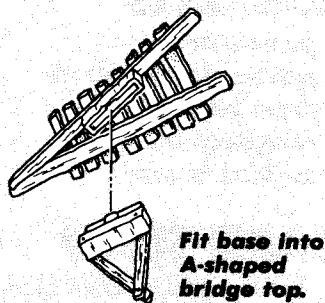

FIGURE 3B



5. Place the 4 tokens in the *Ruin* space. They'll fit best if you stand them up against the inside wall.

6. Fit the jewel in the recessed circle next to the *Idol*.

7. The 5 marbles are your *Fireballs*. Load one *Fireball* into the *Idol Vul-Kar*, as shown in Figure 4. Then place the 4 remaining *Fireballs* in the 4 gameboard indentations showing a flaming fireball.

8. Shuffle the cards, then deal one card facedown to each player. Place the remaining cards facedown next to the gameboard, to form a draw-pile.

Look at your card, but keep it a secret from your opponents. All players do the same.

FIGURE 4
Loading the *Idol's Fireball*



9. Choose a playing piece, and place it on the Start Space. All players do the same.

GAME PLAY

WHO GOES FIRST?

All players roll the die. Highest roller goes first. Play continues to the left after each player's turn.

BASIC PLAY.

As the game begins, players take turns rolling the die and moving along the trails toward the jewel in the center of the gameboard. The first player to reach the jewel captures it, then heads toward the Dock with it. All other players race after the player who owns the jewel, trying to steal it. Throughout the game, players play cards either to help themselves, or to slow their opponents' progress.

On the way to the Dock, ownership of the jewel will probably change several times. The player who reaches the Dock with the jewel wins the game!

A LOOK AT THE GAMEBOARD.

Take a look at Figure 5 on page 6. From Dead Man's Plateau (the Start Space), follow Witchlord Trail toward Vul-Kar Point, where the jewel rests beside the Idol Vul-Kar. The trails that lead to Vul-Kar Point are Thunder Alley, Skeleton Head Beach, Blister Run and Fireflash Chute. Along the way, players can choose to enter a cave, looking for a shortcut to another trail.

One player will capture the jewel on Vul-Kar Point. The owner of the jewel then races for the Dock, following Fireflash Chute and continuing on toward the bridges, Viper Pass and Dock Run. All other players then race after the player who owns the jewel, taking any trails (or caves) that will best help them catch up.

FIGURE 5: The Gameboard Trails

Low Road

Skeleton Head Beach

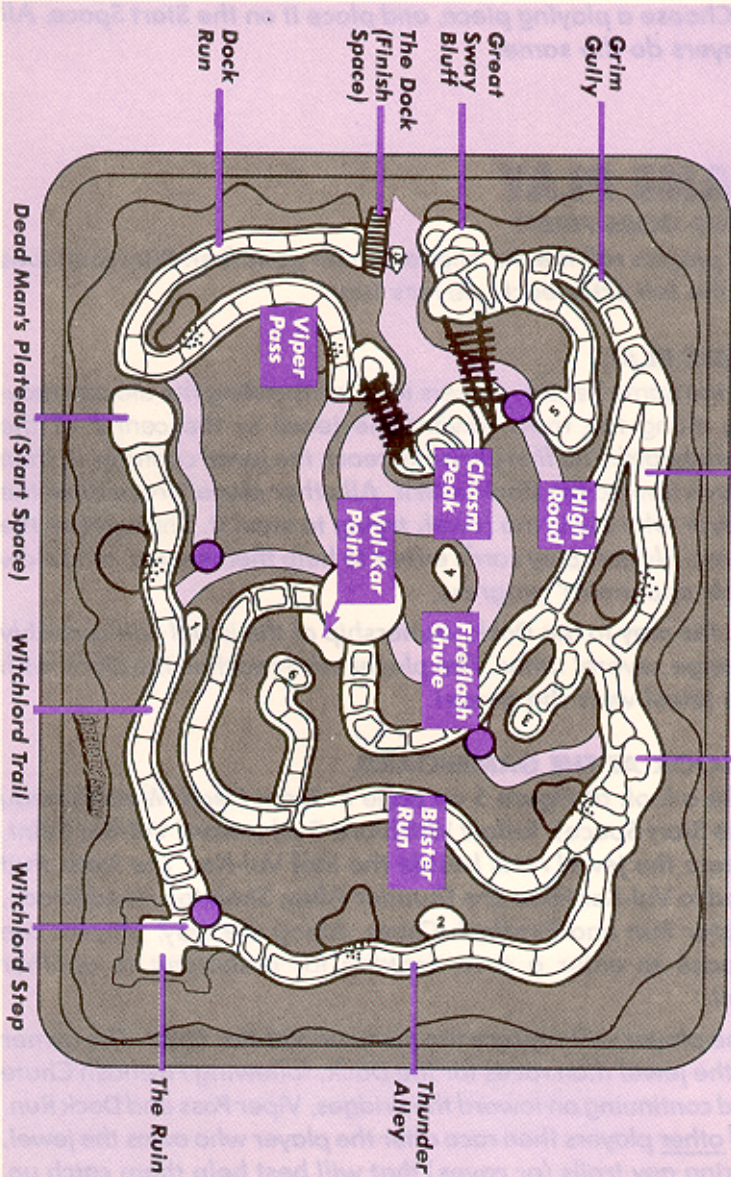

WHAT YOU DO ON YOUR TURN.

Roll and Move: On your turn, roll the die, then move your playing piece along the trails, the number of spaces indicated on the die. As you move, count each space whether it's occupied or not. If you land on a space occupied by an opponent's playing piece, move to the next open space.

Move your playing piece by the full die count. NOTE: You may have to stop short of your full count if you move onto a Special Space. See SPECIAL SPACES, below.

If you roll a "1" on the die, don't move your playing piece along the trail! Instead, you must roll a Fireball! See ROLLING A FIREBALL, on page 9.

You can move along the trails in any direction, as long as you don't move onto the same space twice during one move.

Playing The Cards: Card play is discussed in detail under PLAYING YOUR CARDS on pages 12-15.

Ending Your Turn: Signal the end of your turn by passing the die to the player on your left.

SPECIAL SPACES.

Dark Trail Spaces: Whenever you land on (not just pass over) a dark trail space, take a card from the drawpile and add it to your hand. YOUR 4-CARD LIMIT: You can never have more than 4 cards in your hand at one time. Never draw a card if you already have 4 of them.

Witchlord Step and the Magic Charm Tokens: If you land on or pass Witchlord Step, collect one Magic Charm token from the Ruin. A Magic Charm token can be traded in on any one of your turns, to give you a full hand of 4 cards. You can only collect one token during the game.

How to trade in your token: Return it to the Ruin, then take enough cards from the drawpile to fill your hand to 4 cards.

Vul-Kar Point: To capture the jewel, you don't have to land on

Vul-Kar Point by exact count. After the jewel is captured, Vul-Kar Point may be used by players on Blister Run as a connecting space to Fireflash Chute.

Caves: There are six numbered caves on the gameboard. As an alternative to traveling along the trail, you may enter a cave, hoping for a shortcut to another trail.

1. Counting the cave as a space on your die roll, move your playing piece into the cave from the trail space next to it. It's not necessary to land in a cave by exact die count.

2. On your same turn, roll the die again, and move your playing piece into the cave that matches the number on the die. For example, if you roll a "5," move into Cave 5. If the cave you roll is occupied by your own playing piece or an opponent's, leave your playing piece where it is—don't roll again on this turn.

NOTE: If you roll a "1" while in a cave, move to Cave 1 (if you can), then roll a Fireball! See **ROLLING A FIREBALL**, on page 9.

3. Before rolling the die on your next turn, declare whether you wish to enter a new cave, or to move out of your cave onto the trail. **NOTE:** Cave 4 is a dead-end cave. From Cave 4, you must roll the die to enter a new cave.

4. If you wish to move to a new cave, follow Steps 2 and 3, above. If you wish to move out of the cave and onto the trail, roll the die, then move out along the trail, starting on the space next to the cave you're exiting.

Bridges: A bridge counts as a space on your die roll. If an opponent's playing piece occupies a bridge, you may cross it. If there is no playing piece on the bridge, you must stop your playing piece on the bridge—even if you haven't moved your full die count.

The Dock: The Dock is the Finish Space. You don't have to land on the Dock by exact count.

ROLLING A FIREBALL.

Whenever you roll a "1" on the die, you must roll one of the 5 Fireballs down a trailway or rollway. (See the arrows in Figure 6, on page 11, for trailways and rollways leading from each of the 5 Fireballs.) Any playing pieces hit as the result of the rolling Fireball are penalized. See **GETTING FIREBALLED**, below.

To roll a Fireball, follow the rules below.

1. If possible, the Fireball you roll must hit at least one target (playing piece) along a trail. If all playing pieces are in safe areas except your own, you must choose your own playing piece as the target!
2. Push (don't flick) the Fireball down a trailway or rollway that leads to your target(s). If you're rolling the Vul-Kar Fireball, turn Vul-Kar so that its mouth faces the chosen trailway or rollway. Then push the Fireball through the tunnel, out of Vul-Kar's mouth.
3. When the Fireball stops rolling, return it to its original location.

GETTING FIREBALLED.

Getting Fireballed on a Trail: If your playing piece is knocked down, moved or even touched by a rolling Fireball, or by any other game part as a result of a rolling Fireball, it is Fireballed! Follow the rules below.

1. Immediately, place your playing piece on its side in the specified smolder pit. (Figure 6 on page 11, and the chart beside it, show which smolder pits belong to which trails). Any number of playing pieces may occupy the same smolder pit.

Fireballed With the Jewel: If you own the jewel, place it on the Rock Chip trail space right next to your smolder pit. (See Figure 6 for an example of a Rock Chip space). The jewel is now un-

owned, and the first player to move onto or pass the Rock Chip space captures it!

2. On your next turn, place your playing piece upright in the smolder pit. You cannot roll, move or play any cards on this turn.

3. On your following turn, roll the die, then move your playing piece out onto the trail, starting on the Rock Chip space right next to your smolder pit.

Getting Fireballed on a Bridge: If your playing piece is knocked off a bridge, it is Fireballed! Move it immediately to the water penalty area (shown in Figure 6) at the bottom of Great Sway Bluff. You do not lose your next turn. However, to get back to the bridges again you must climb the 5 trail spaces to the top of the bluff from the water's edge.

Fireballed With the Jewel: If you own the jewel when Fireballed on a bridge, place it on the bridge. The jewel is now unowned, and the first player to move onto the bridge captures it!

FIREBALL PENALTY AREAS

<i>If your playing piece is Fireballed here...</i>	<i>...you must move here.</i>
Witchlord Trail	A
Thunder Alley	B
Skeleton Head Beach Blister Run	C
Fireflash Chute High Road Low Road	D
Viper Pass	E
Dock Run	F
Either of the two bridges	W

NOTE: The dark gray trails and spaces are not affected by rolling Fireballs.

FIGURE 6: Fireball Trailways, Rollways and Penalty Areas

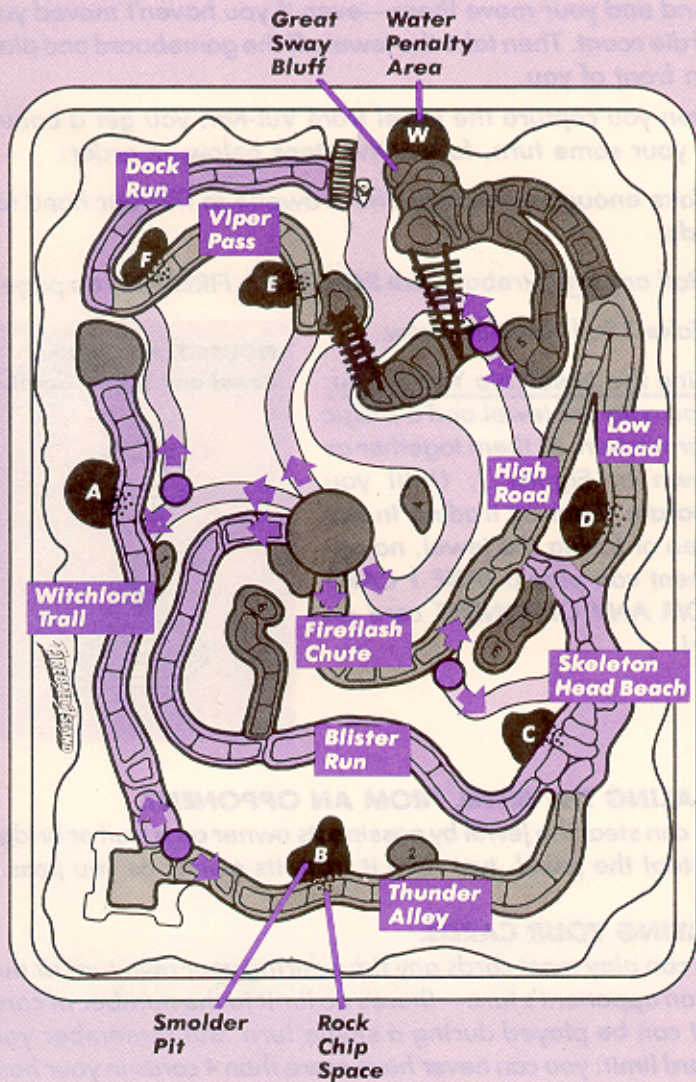

CAPTURING THE JEWEL FROM VUL-KAR.

Counting Vul-Kar Point as a space on your die roll, move onto it and end your move there—even if you haven't moved your full die count. Then take the jewel off the gameboard and place it in front of you.

When you capture the jewel from Vul-Kar, you get a bonus! On your same turn, follow the steps below, in order:

1. Take enough cards from the drawpile to fill your hand to 4 cards.
2. Roll any one Fireball. See ROLLING A FIREBALL, on page 9.
3. Take 3 full turns in a row.

Fitting the Jewel Into Your Token:

If you own the jewel and a Magic Charm token, fit them together as shown in Figure 7. Until you separate them by trading in the token or losing the jewel, no opponent can play a TAKE 1 CARD FROM ANY OPPONENT card on you!

FIGURE 7: Fitting the Jewel and Token Together

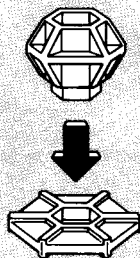

STEALING THE JEWEL FROM AN OPPONENT.

You can steal the jewel by passing its owner on a trail or bridge. To steal the jewel, just take it from its owner as you pass.

PLAYING YOUR CARDS.

You can play most cards any time during your own turn or during an opponent's turn—there's no limit to the number of cards that can be played during a single turn. But remember your 4-card limit: you can never have more than 4 cards in your hand at one time.

Place the cards you play in a faceup discard pile next to the drawpile. If the drawpile runs out, shuffle the discard pile and turn it face-down to create a new drawpile.

FIREBALL! Play this card any time on your own turn or on an opponent's turn. Then roll a Fireball according to the rules on page 9.

FAKE JEWEL! Play this card only when an opponent tries to steal the jewel from you. You keep the jewel, and the opponent must move on—empty-handed!

CANCEL ANY CARD EXCEPT FIREBALL CARD! You may play this card on top of a card just played—even another CANCEL card—to cancel its effect before any action is taken. **EXCEPTION:** The FIREBALL! card can never be canceled!

MAGIC TALISMAN STOPS A FIREBALL! This card prevents you or an opponent from rolling any of the 5 Fireballs. Play it when an opponent is just about to roll a Fireball; or play it after you roll a "1" on the die, if your playing piece is the target.

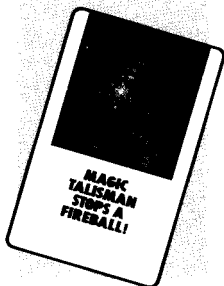
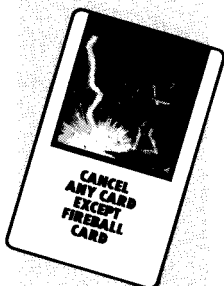

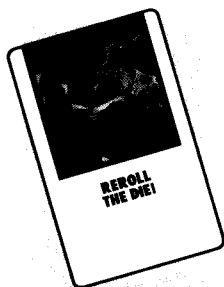

REROLL THE DIE! Play this card after you or an opponent rolls the die. The player who rolled must ignore the first roll, and roll again. If the first die roll was a "1," a Fireball is not rolled.



TAKE ANOTHER TURN AFTER YOUR TURN! After any of your turns, play this card for an extra full turn.



TAKE 1 CARD FROM ANY OPPONENT Play this card on your own turn or on an opponent's turn. Then take one card at random from any opponent's hand. **NOTE:** This card can never be played against a player who owns the jewel and the token at the same time!



MOVE AHEAD (4 SPACES, 5 SPACES OR 6 SPACES) INSTEAD OF ROLLING DIE Play one of these cards on your turn, to move ahead the indicated number of spaces. Or play one on an opponent's turn, to force the opponent to move ahead the indicated number of spaces.

MOVE ANY OPPONENT BACK (1 SPACE, 2 SPACES OR 3 SPACES) Play one of these cards on any opponent's turn, to move the opponent back on the trail the number of spaces indicated on the card. If you play the card before the opponent rolls the die, the opponent must move back before rolling. If you play the card after the opponent has rolled the die, the opponent must finish the move, then move back.



NOTE: These cards do not move players out of caves, smolder pits, or the water penalty area at the bottom of Great Sway Bluff. If one of these cards moves an opponent back onto an unoccupied bridge, the opponent must end his or her move on the bridge.



DOUBLE THE NEXT DIE ROLL Play this card on your own turn or on an opponent's turn, to double the next die roll. For example, a die roll of "1" becomes a "2"—and a Fireball is not rolled.

HOW TO WIN THE GAME

The player who reaches the Dock with the jewel wins the game!