

FLYING FIGHTERS™

AGES: 5 AND UP

AH-64 APACHE ATTACK HELICOPTER "1st CAVALRY DIVISION" INSTRUCTIONS

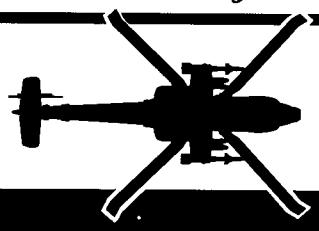

Remove all pieces from plastic frames.
If you have difficulty, use safety scissors.

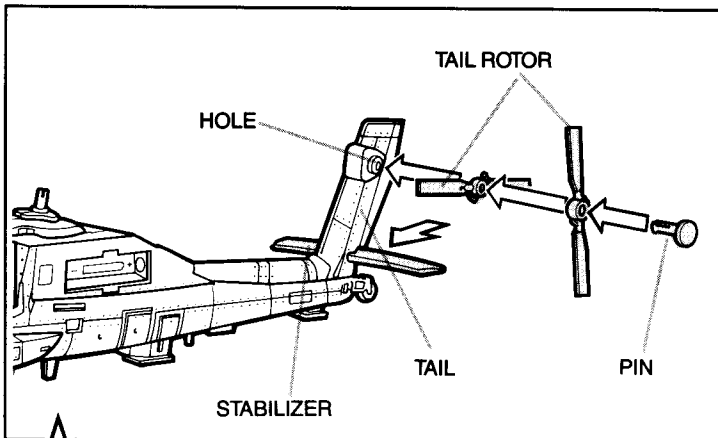

1 Fit tail rotor blades onto tail rotor pin. Snap tail rotor assembly into hole in tail section. Snap stabilizer into slot in tail as shown.

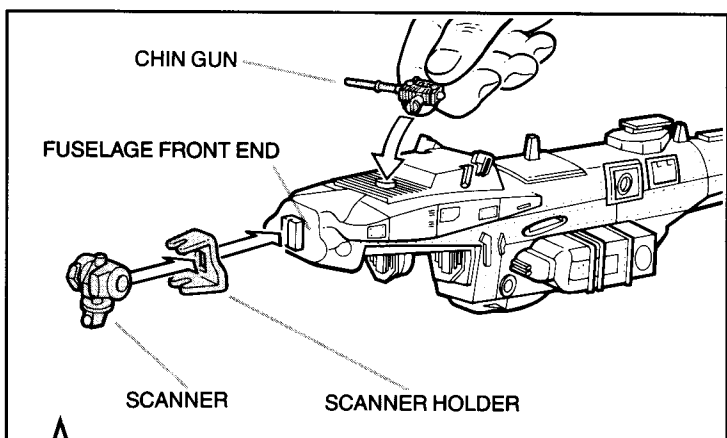

2 Turn fuselage upside down. Snap chin gun into hole in front end of helicopter. Snap scanner holder onto fuselage front end. Snap scanner into scanner holder as shown.

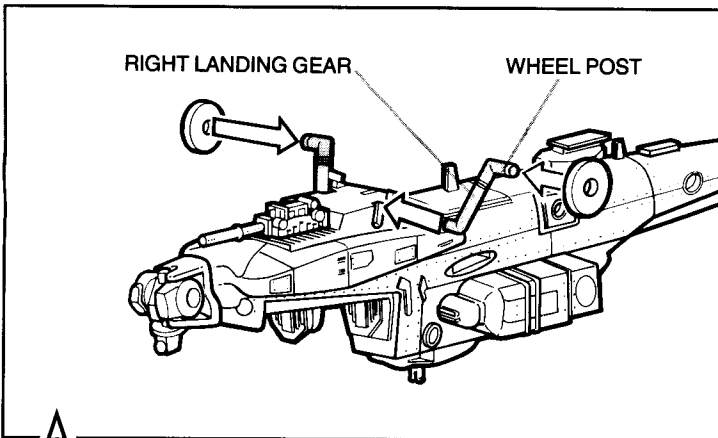

3 Fit wheel post on right landing gear strut, marked "R". Repeat for left landing gear strut, marked "L".

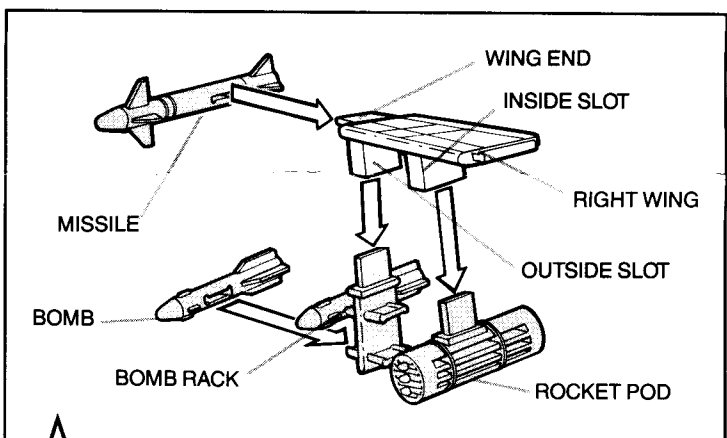

4 Slide bomb rack into outside slot in right wing. Snap rocket pod into inside slot in right wing. Repeat for left wing pylons. Fit missile onto tab on end of wing as shown.

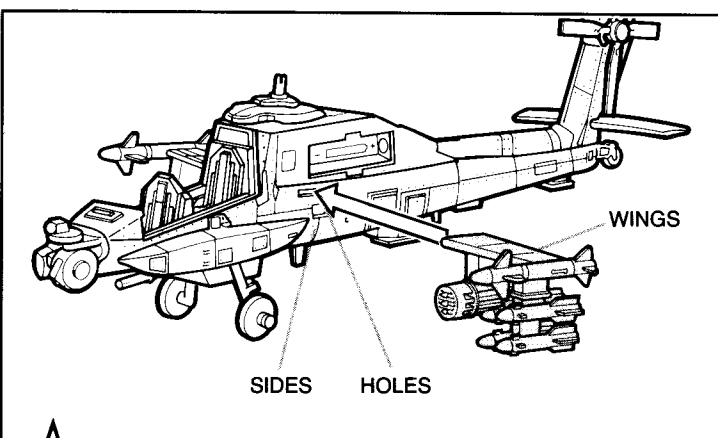

5 Turn fuselage right side up. Snap right and left wings into holes in fuselage sides as shown.

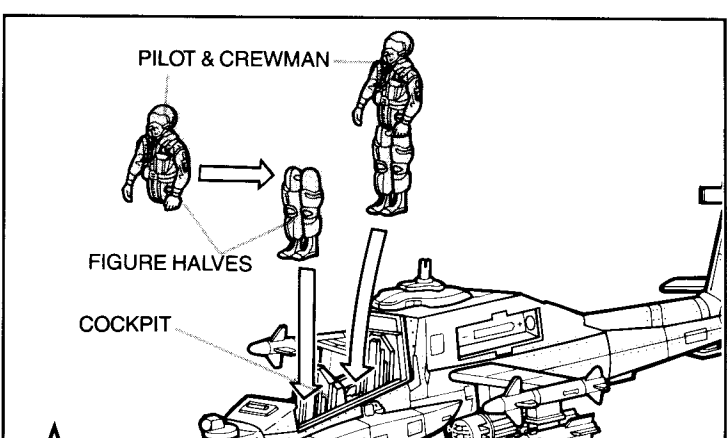

6 Snap figure halves together. Place figure into cockpit. Repeat for other figure.

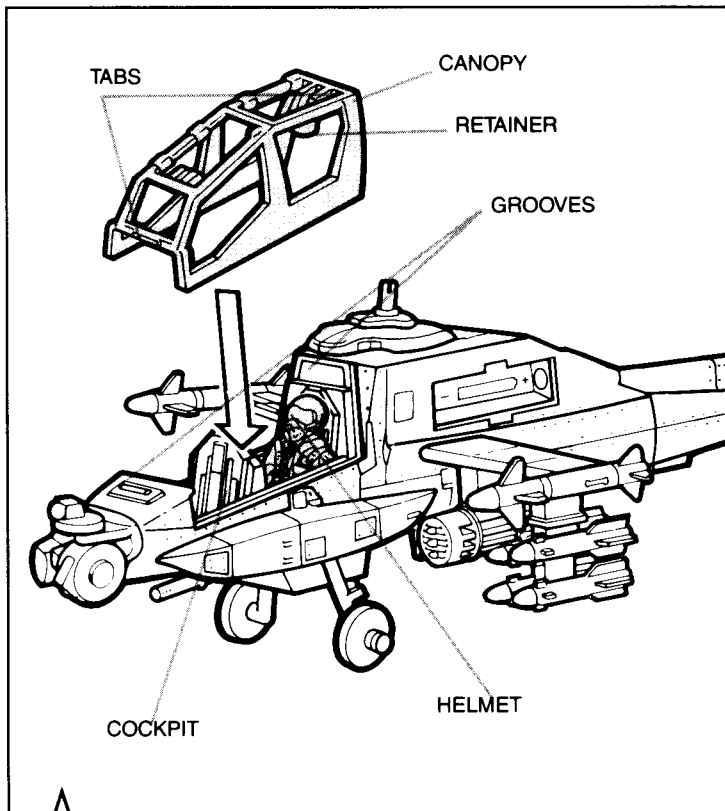

7 Snap front and rear tabs on canopy into front and rear grooves in cockpit area. Make sure figures' retainers fit over each one's helmet as shown.

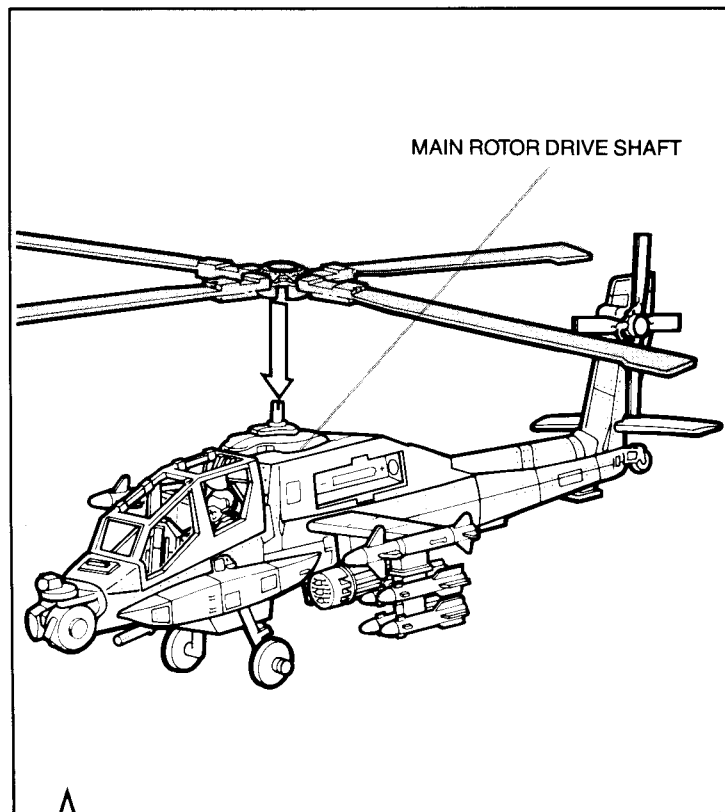

9 Snap rotor hub onto main rotor drive shaft as shown.

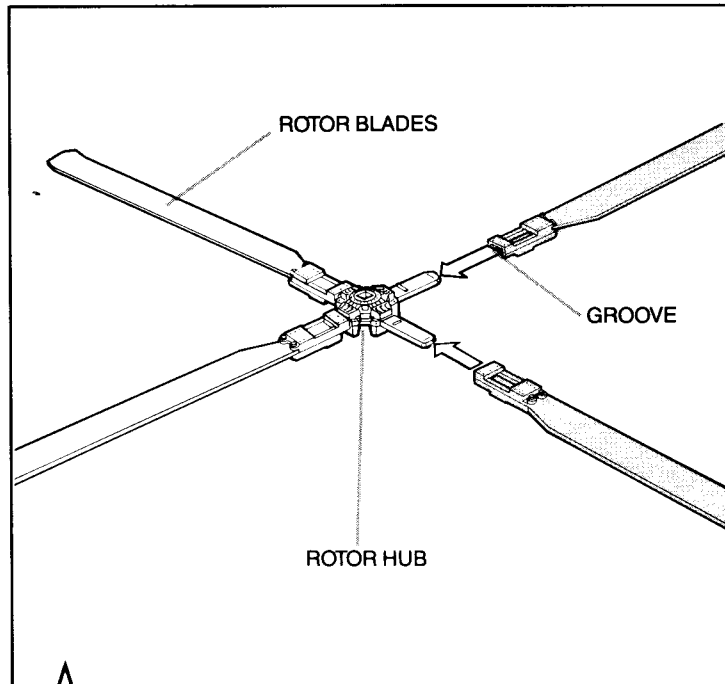

8 Flatten blades if they come bent in package. Slide main rotor blades onto rotor hub and snap into place. Make sure rotor blade posts lock into groove on rotor hub.

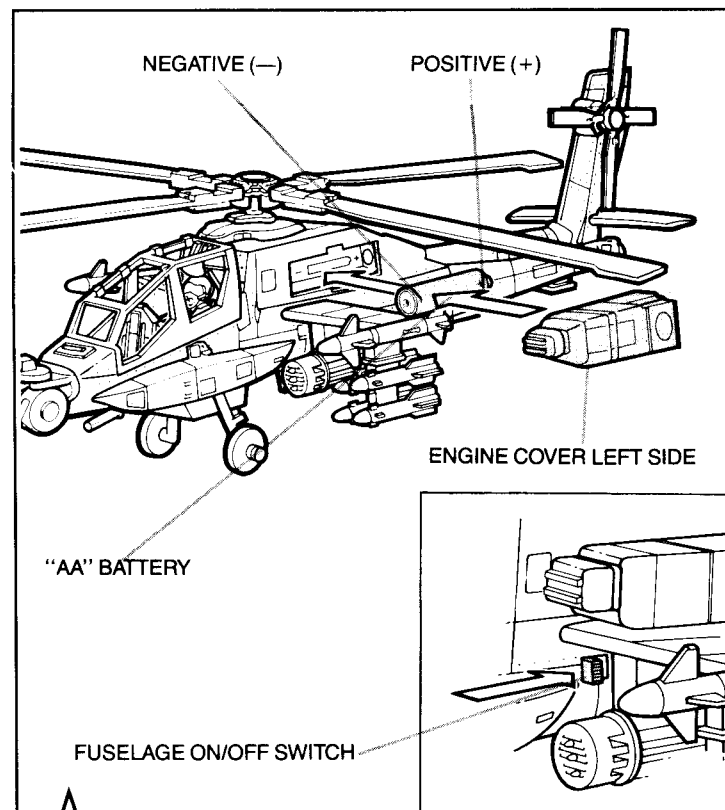

10 Insert one "AA" size battery into left side engine area battery compartment as shown. Be sure the positive end (+) and the negative end (-) on the battery match the corresponding markings in the engine area. Snap left side engine cover over engine area. To activate rotor blades, slide the fuselage ON/OFF switch in the direction indicated. Should blades not turn when switch is on, start with hand.

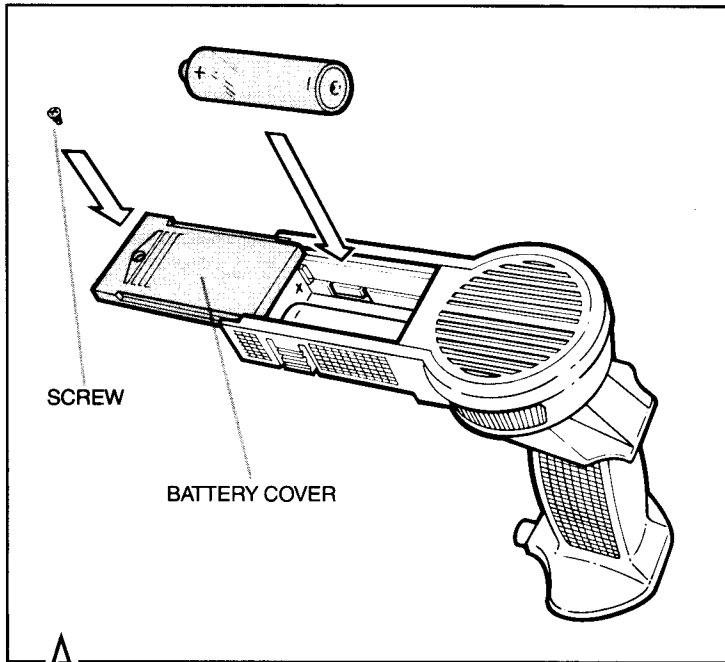

11 Place two "AA" alkaline batteries into compartment as shown. Be sure positive end (+) and negative end (—) on batteries match the corresponding markings in the compartment. Using a Phillips® head screwdriver (not included), slide and screw compartment cover onto compartment.

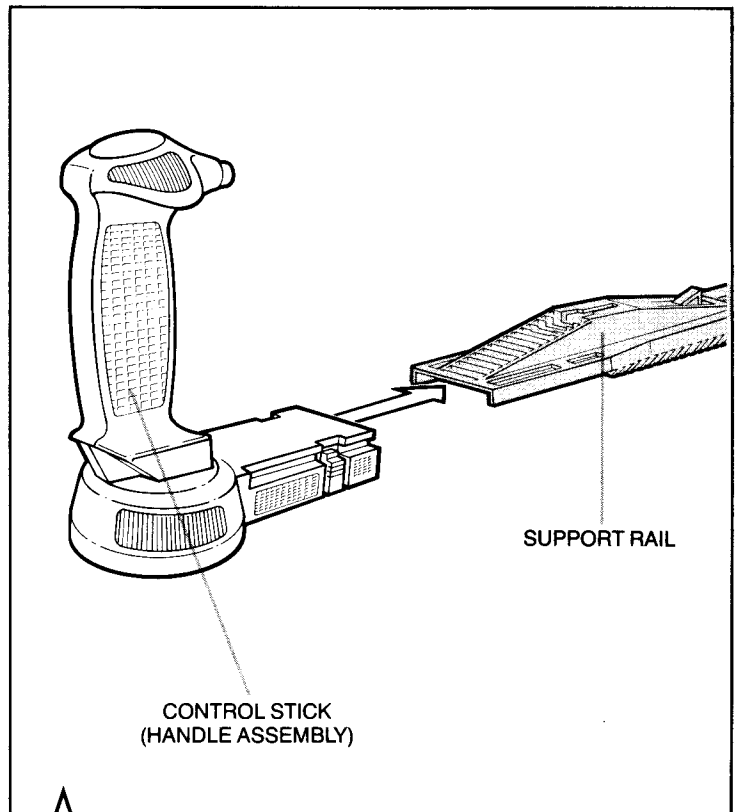

12 Slide and snap helicopter support rail onto control stick as shown.

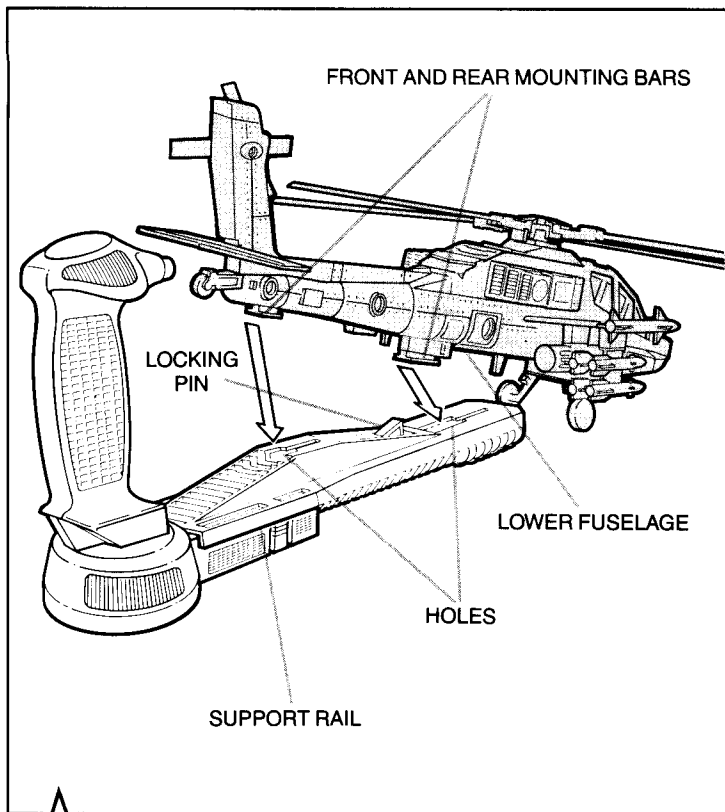

13 Align front and rear mounting tabs on lower fuselage with holes in helicopter support rail as shown. Slide fuselage forward until fuselage locks into place with helicopter support rail. To remove helicopter from support rail, grasp and slide fuselage toward rear and lift outward.

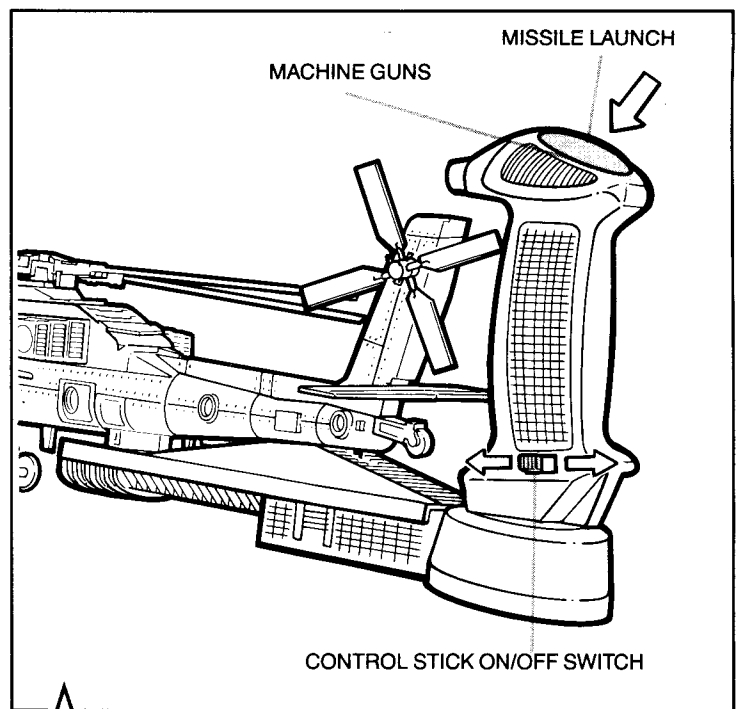

14 To produce in-flight electronic sounds, slide control stick ON/OFF switch into the ON position as indicated. Hold control stick in one hand and press control stick button to the left to activate the machine gun, and to the right for the missile launch. Activate fuselage ON/OFF switch on fuselage side to produce rotor blade sound. (See Step 10) NOTE: Machine gun and missile fire sounds will not activate until helicopter sound is up to full speed. CAUTION: Keep rotor blades away from face and eyes.

LABEL PLACEMENT

Peel and apply labels as shown.

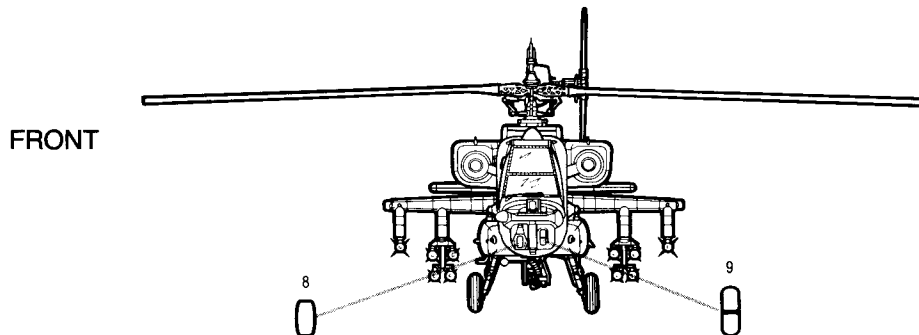
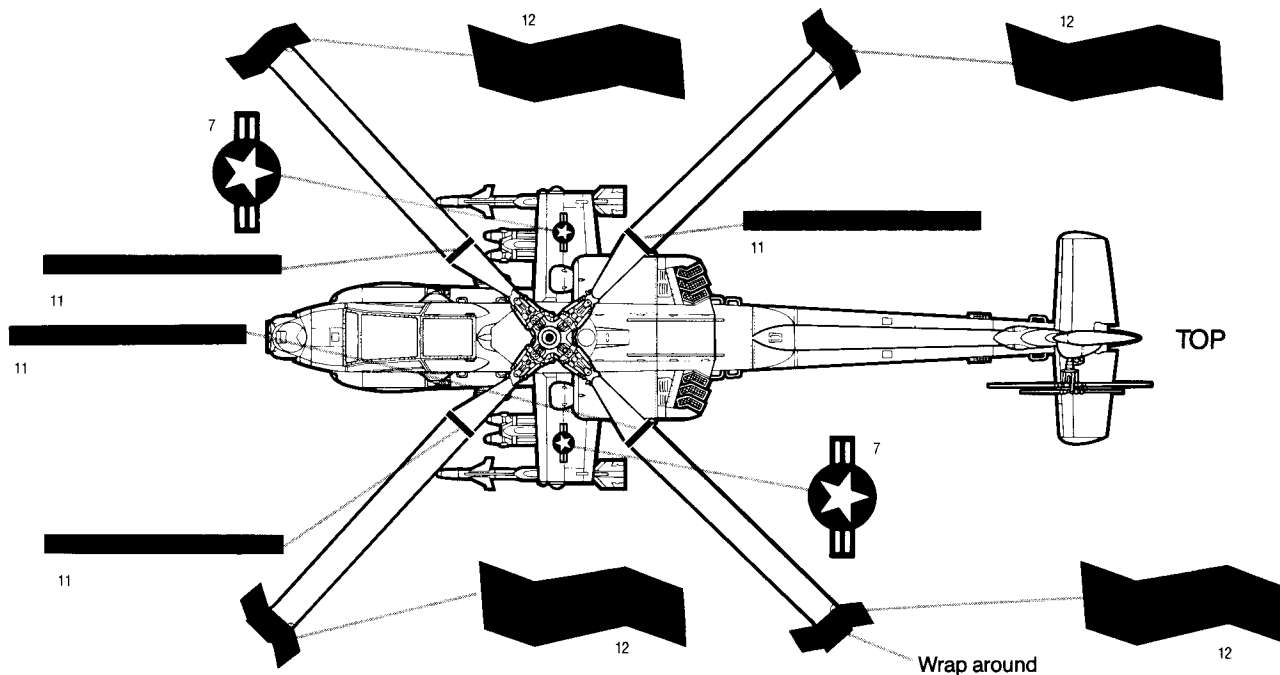
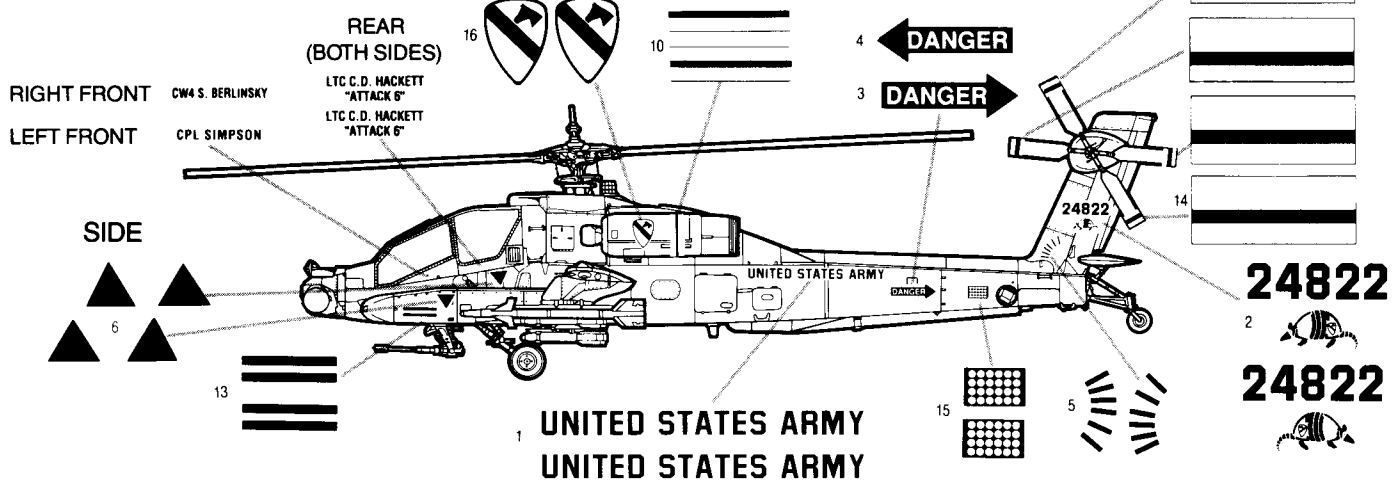

Labels grouped together go on opposite sides of helicopter.