

FLYING FIGHTERS™

AGES 5 & UP

F/A-18 HORNET "WILDCATS" INSTRUCTIONS

Remove all pieces from plastic frames
If you have difficulty use safety scissors

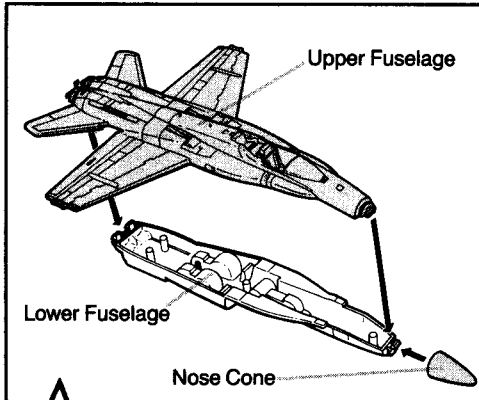
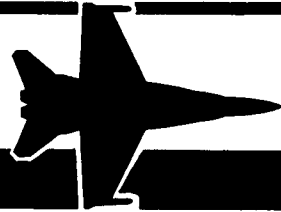

1 Snap upper fuselage onto lower fuselage. Align indentation in nose cone with tab on fuselage front end and snap together.

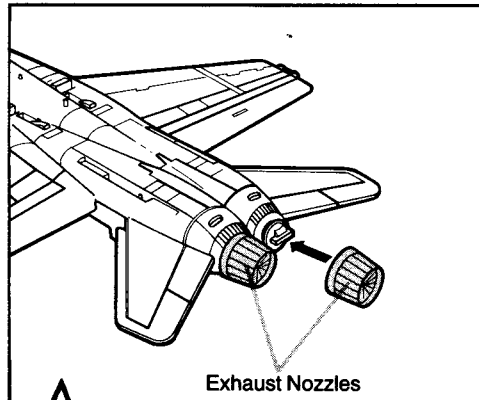

2 Snap exhaust nozzles over fuselage rear end.

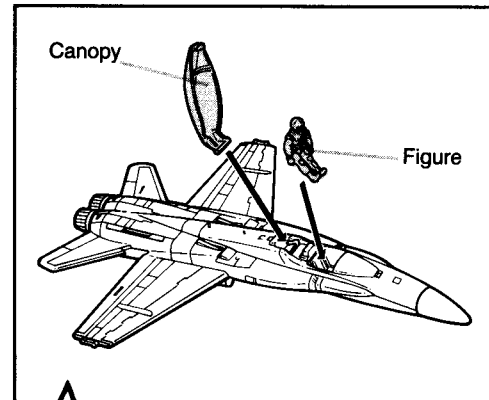

3 Snap figure halves together. Place figure into cockpit. Remove F/A-18 tab from canopy. Snap canopy over cockpit and slide toward rear of plane.

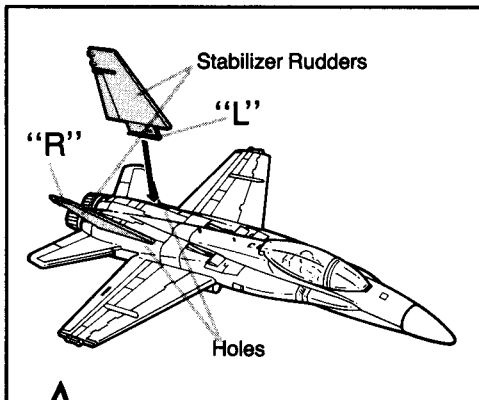

4 Snap right and left stabilizer rudders, labeled "L" and "R", into holes in rear of fuselage.

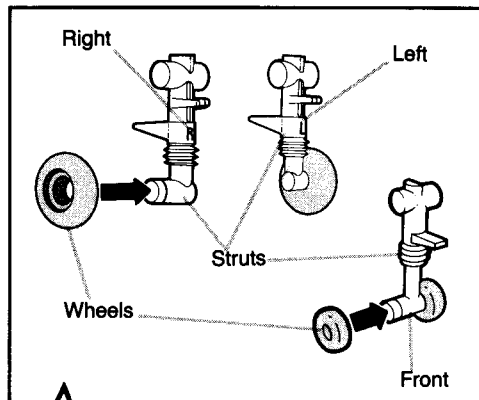

5 Snap wheels onto landing gear struts so that large hole is facing outside.

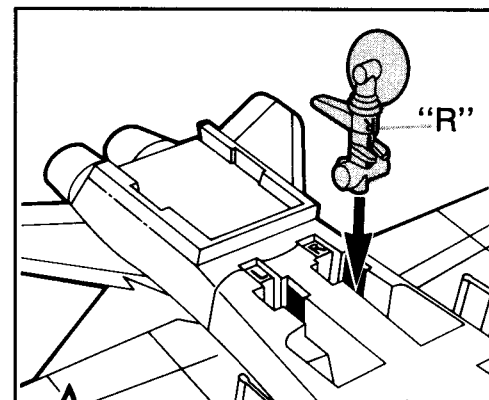

6 Turn fuselage upside down. Match "R" on fuselage with "R" on landing gear, then snap into compartment as shown. To flip down landing gear, press down on tabs.

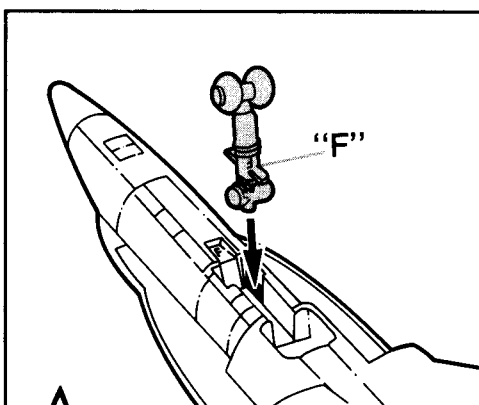

7 Snap landing gear, marked "L" and "F", into landing gear compartments, also labeled "L" and "F", as shown. To flip down landing gear, press down on tabs.

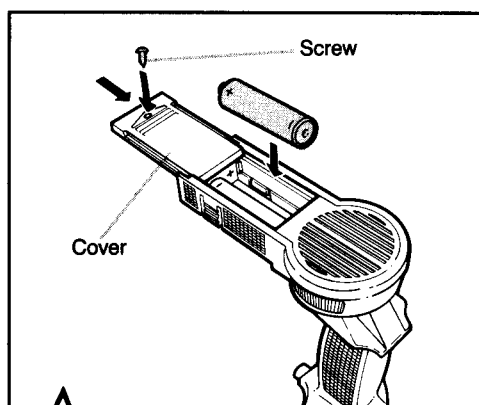

8 To insert batteries, unscrew the battery compartment cover using a Phillips head screwdriver (not included). Place two "AA" alkaline batteries into compartment as shown. Be sure positive end (+) and negative end (-) on batteries match the corresponding markings in the compartment. Slide and screw compartment cover onto compartment.

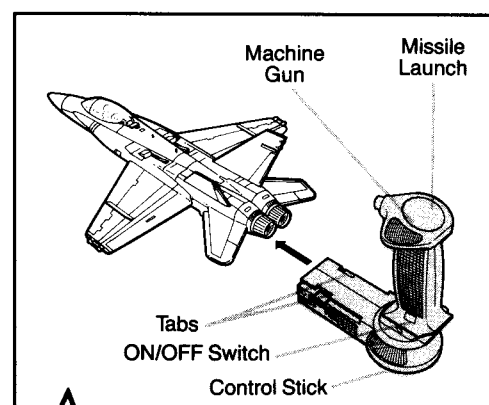

9 Slide and snap control stick into rear of fuselage. To activate, flick ON/OFF switch into the ON position. To remove, press side tabs and pull. To produce in-flight electronic sounds, hold control stick in one hand then point plane upward for acceleration or downward for deceleration. Press control stick button to the left to activate the machine gun, and to the right for the missile launch.

MISSILE PLACEMENT

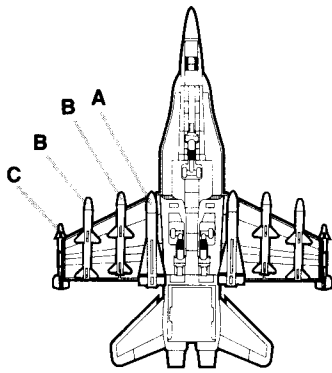

Air-to-Air Missions

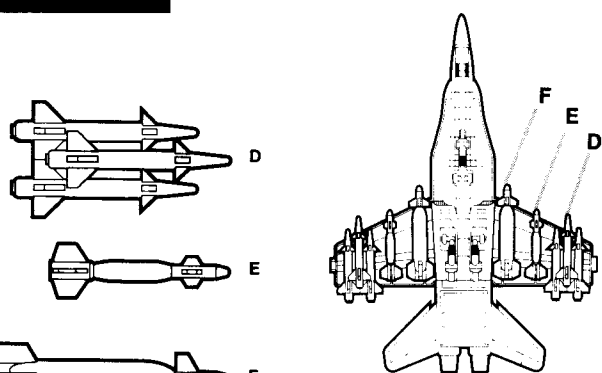
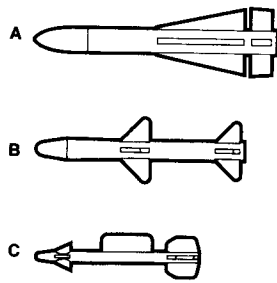

Air-to-Ground Missions

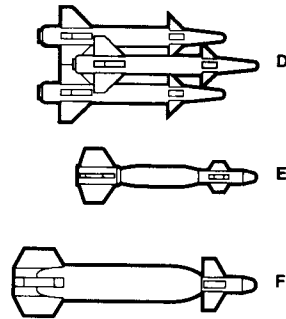

WEAPONS LOADING FOR AIR-TO-AIR MISSIONS:

- A (2) Long range AIM-54 Phoenix missiles
- B (4) Medium range AIM-7 Sparrow missiles
- C (4) Short range AIM-9 Sidewinder missiles

WEAPONS LOADING FOR AIR-TO-GROUND MISSIONS:

- D (2) AGM-12B Bullpup missiles
- E (2) GBU-10 Laser Guided Bombs
- F (2) GBU-12 Laser Guided Bombs

Your orders are to knock out incoming enemy aircraft using your outlined air-to-air missiles listing, then return to base and rearm your fighter with the suggested air-to-ground ordnance to take out its air base.

LABEL PLACEMENT

Peel and apply labels as shown.

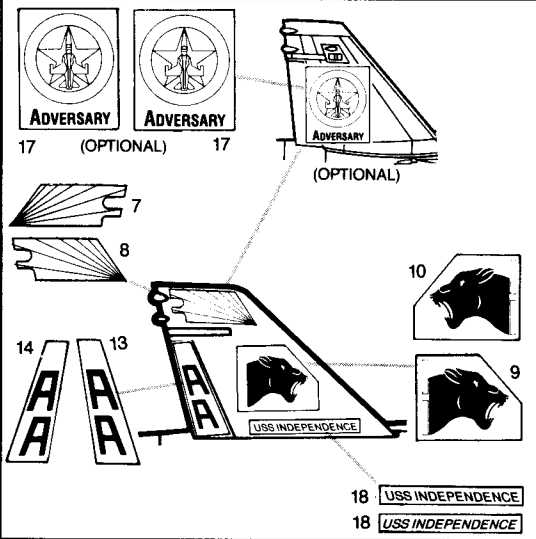

TOP

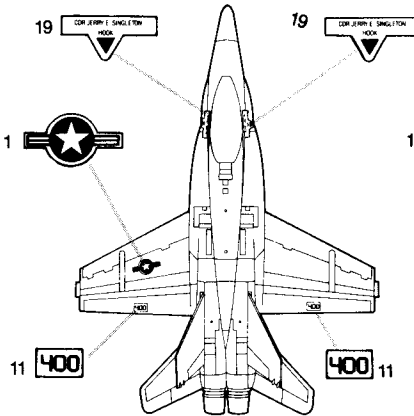

BOTTOM

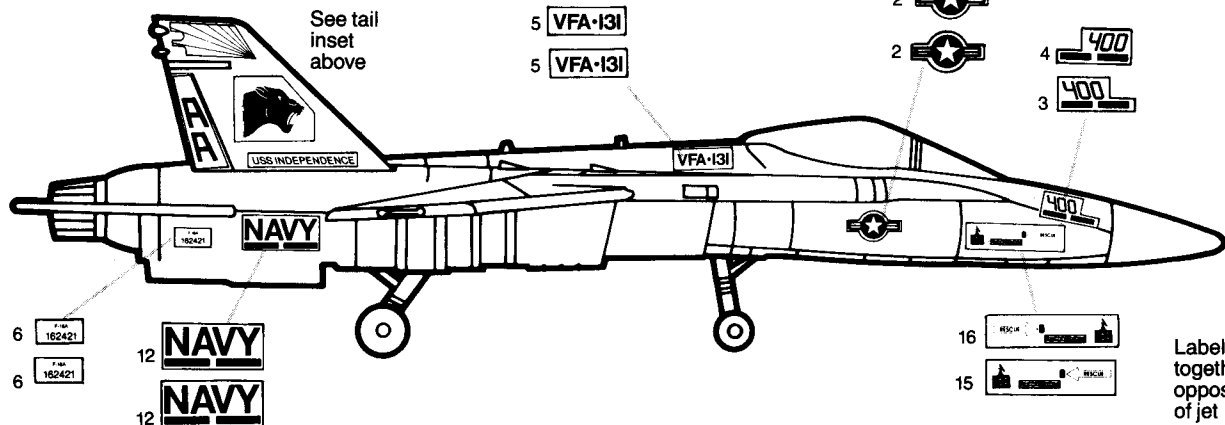
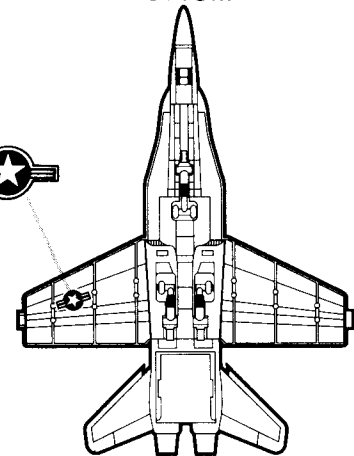

Labels grouped together go on opposite sides of jet