

Remove all pieces from plastic frames. If you have difficulty, use safety scissors.

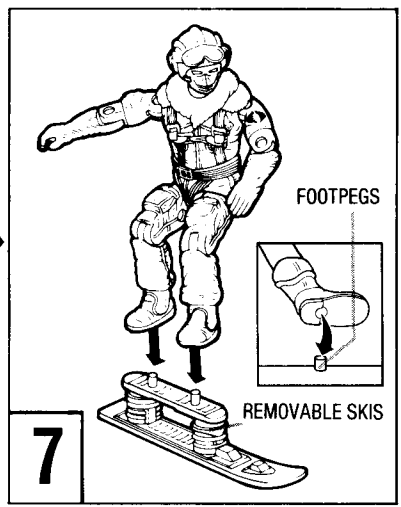
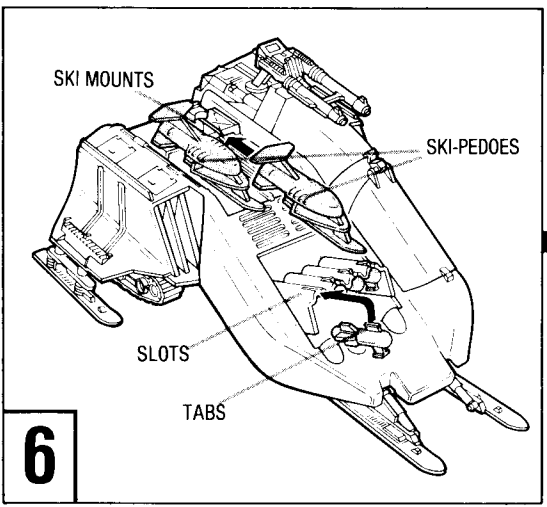
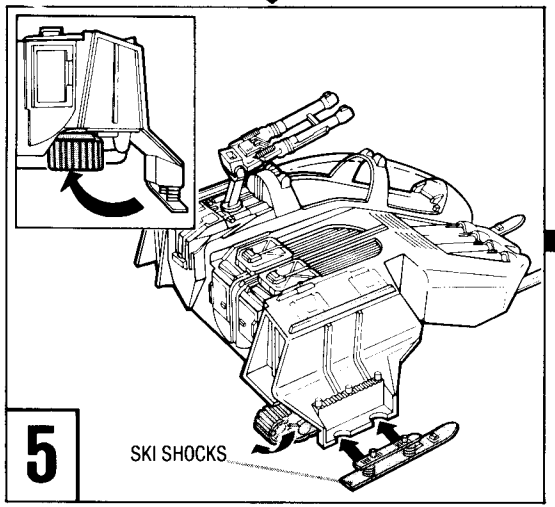
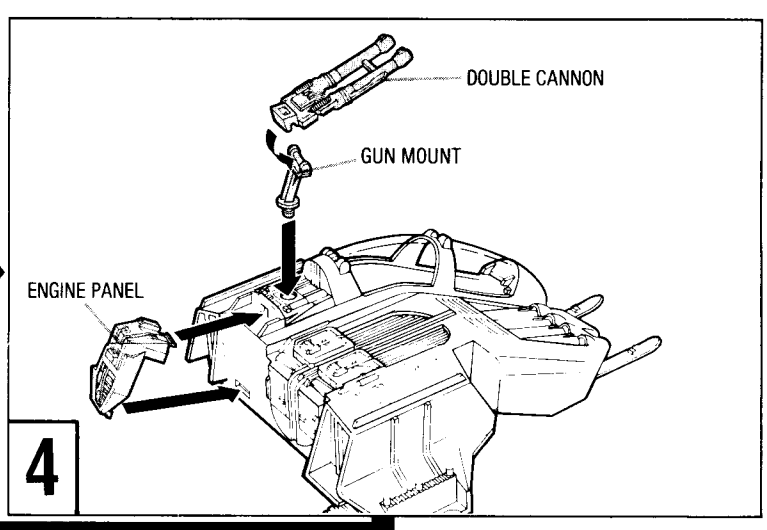
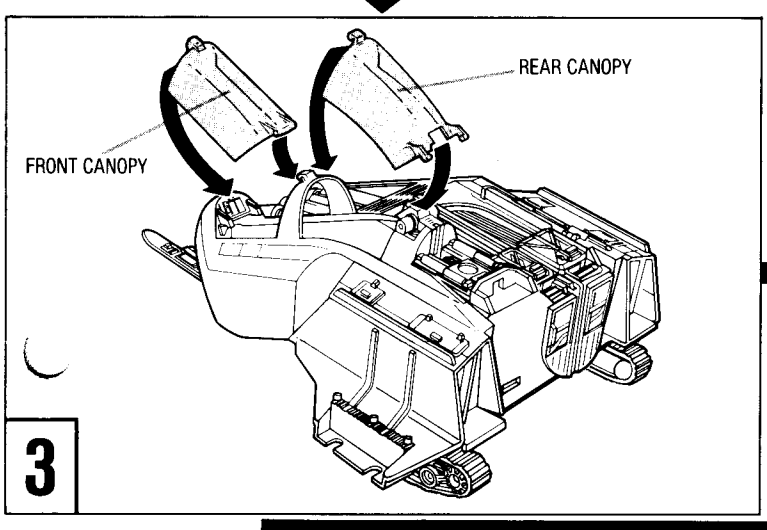
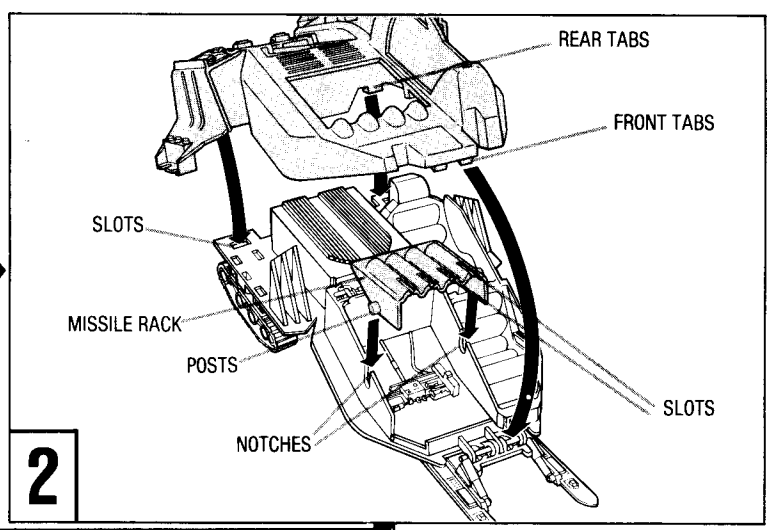
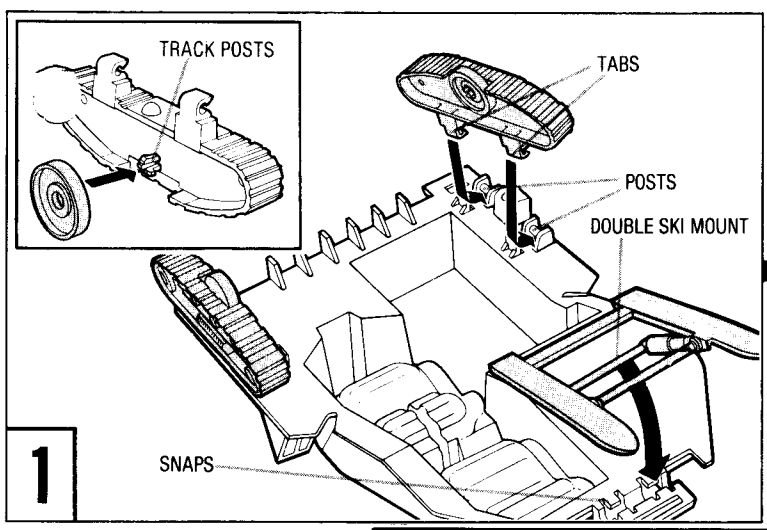

- 1 Snap wheels over track posts. With wheels on inside of track, *snap one tab at a time* over posts underneath chassis. Snap rear bar of double ski mount into snaps underneath front of body. (ILL. 1)
- 2 With *slots in missile rack facing forward*, rest posts in notches. Fit body top over chassis and snap 2 rear tabs and 2 front tabs into slots in chassis. (ILL. 2)
- 3 Mate FRONT (straight) and REAR (curved) canopies (marked FRONT and REAR). Snap one post at a time into holes in FRONT and REAR cockpits. (ILL. 3)
- 4 Hook top tab on rear engine panel into snap on rear of body. Snap lower tab into slot. Snap gun mount into hole behind cockpit. Snap double cannon onto gun mount post. (ILL. 4)
- 5 Slide ski shocks into notches on each side of vehicle. **TRACKS PIVOT INWARD AND LOCK INTO PLACE WHEN VEHICLE IS IN "SKI MODE".** (ILL. 5)
- 6 Slide ski-pedoes *all the way* into ski mounts. Slide TABS ON TOP OF MISSILES into missile rack slots. Pivot missile rack to close. (ILL. 6)
- 7 Cobras can ski on removable rear skis when vehicle is in "track mode". Place up to 10 additional figures on footpegs. (Includes Cobra ICE VIPER.) (ILL. 7)

COBRA WOLF

- 1) "SNARL" (SNOW ENVIRONMENT - ADVANCED ATTACK RANGE LASER) SKI TORPEDOS
- 2) DUAL TRACK PROPULSION UNITS
- 3) PIVOTING REAR SKI SUPPORT ARM
- 4) CROSS-WEAVE CARBON BASE REAR SKIS
- 5) SINTERED-BASE SKIS/NITROGEN COMPRESSION SHOCKS
- 6) SELF-CLEARING SLOPED NOSE SECTION
- 7) DUAL-LAYER INTERNAL-HEATING CANOPIES
- 8) PILOT COMMAND SEAT/HUD (HEAD UP DISPLAY)
- 9) HIGH-VISIBILITY REAR GUNNER SEAT
- 10) "RIPPER" PIVOTING 20 MM REPEATING CANNONS
- 11) SIDE-MOUNTED PERSONNEL TRANSPORT PLATFORMS
- 12) WEATHER-CUTTING PNVs (PILOT NIGHT VISION SYSTEM)
- 13) WHAM-4 (WINTER-ORIENTED HEAVY-ORDNANCE SURFACE-TO-AIR MISSILES
- 14) PIVOTING REMOTE MISSILE LAUNCH PANEL
- 15) GUNNER-OPERATED FIRE CONTROL COMPUTER
- 16) OFFICIAL G.I. JOE BATTLE INSIGNIA SPECIFICATIONS.

To apply your official battle insignias, refer to the diagram below.

