

Remove all pieces from plastic frames. If you have difficulty, use safety scissors.

Contents: Body top & bottom, turret, turret base, engine cover, right & left hatches, front & rear gatling guns, rocket pod, cannon barrel, battering ram, turret struts, mine box, support bar, 4 missiles, 4 mines, 4 wheels, G.I. Joe folder, label sheet and instructions.

NOSE GUN/BODY ASSEMBLY

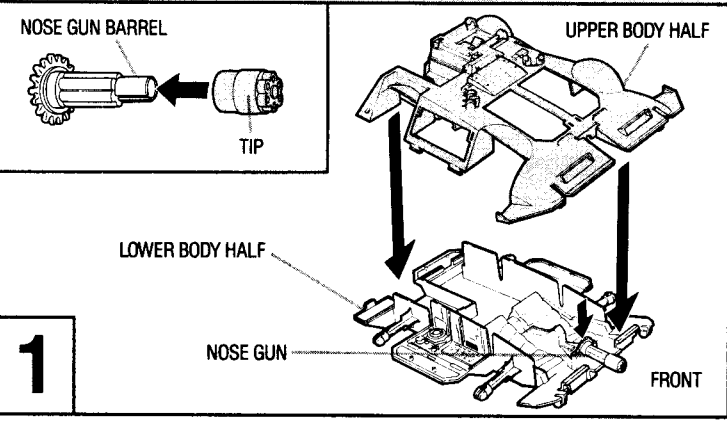

1

WHEEL INSTALLATION

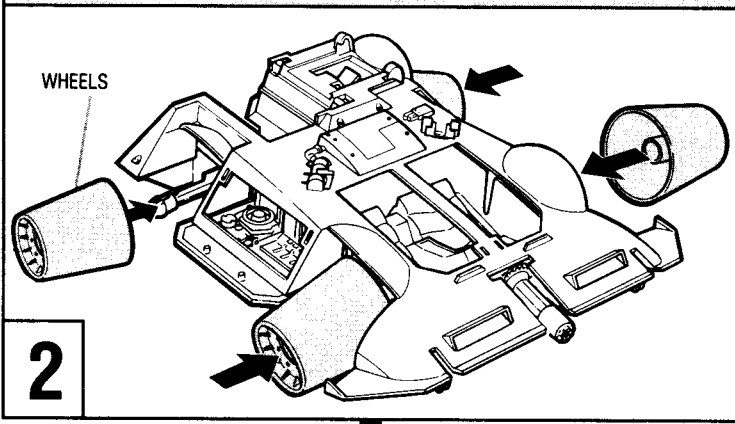

2

MINE DISPENSER INSTALLATION

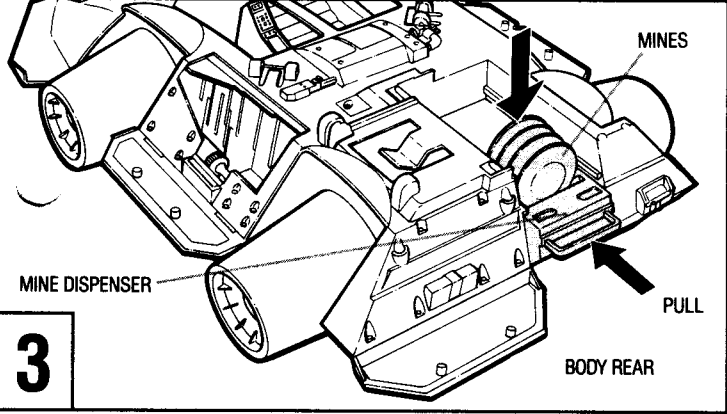

3

TURRET ASSEMBLY

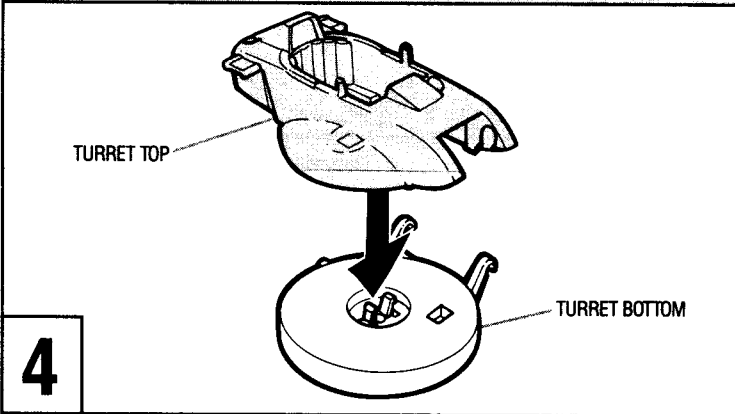

4

MACHINE GUN IMPLEMENTATION

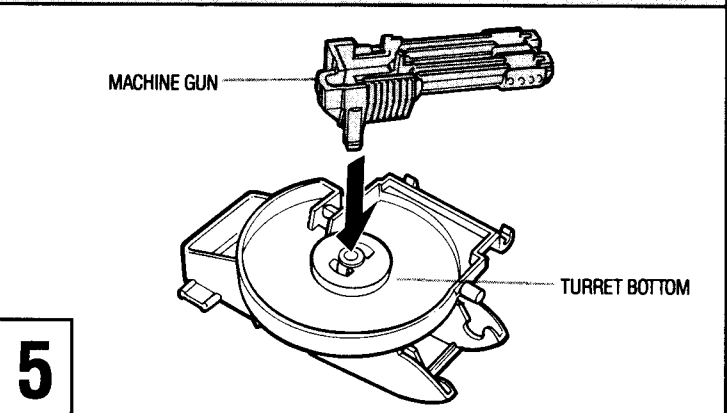

5

TURRET CANNON

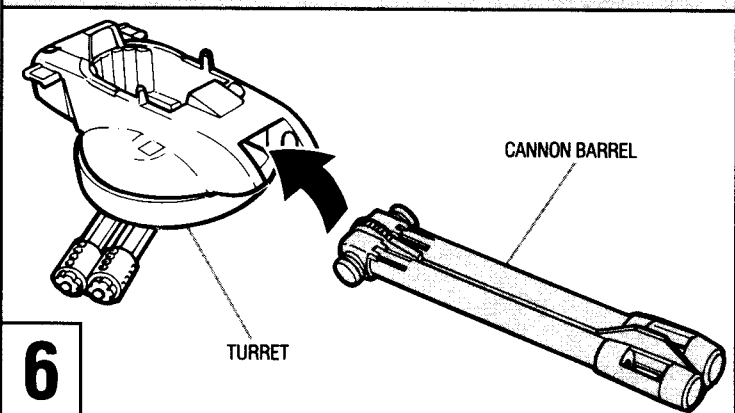

6

- 1 Snap nose gun tip onto nose gun barrel. (INSET) Fit nose gun into slot in front end of lower body half, then snap upper body half over lower body half trapping nose gun. (ILL. 1)
- 2 Snap wheels (4) over posts on body sides. (ILL. 2)
- 3 Slide mine dispenser into body rear. Load 4 mines into dispenser as shown. To activate, pull out dispenser. (ILL. 3)
- 4 Snap turret top onto turret bottom. (ILL. 4)
- 5 Turn turret upside down. Snap machine gun over post on turret bottom. (ILL. 5)
- 6 Turn turret right side up. Snap cannon barrel into turret as shown. (ILL. 6)

STRUT ASSEMBLY

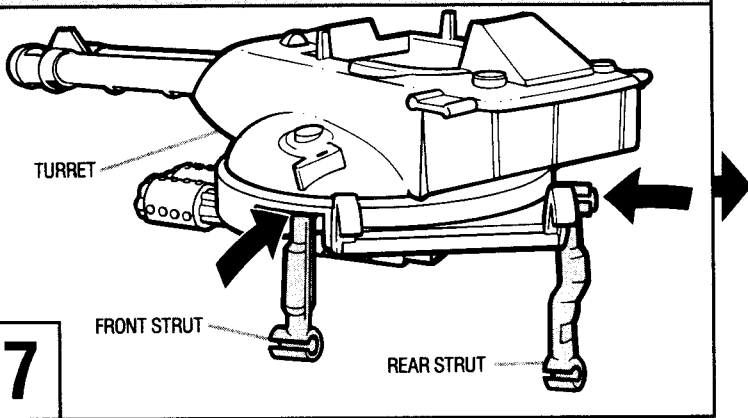

MISSILE LAUNCH PLATFORM INSTALLATION

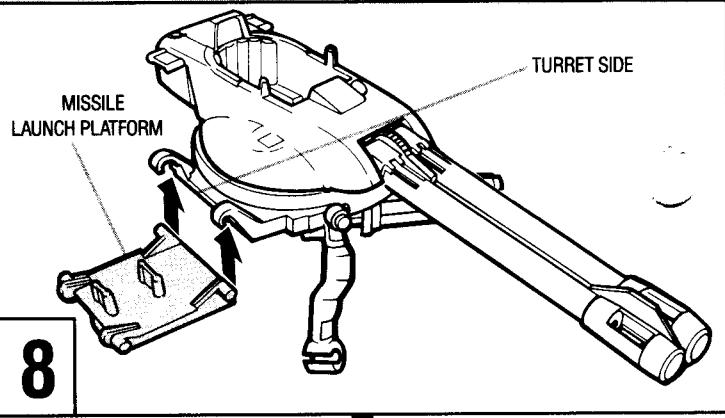

TURRET ACTIVATION

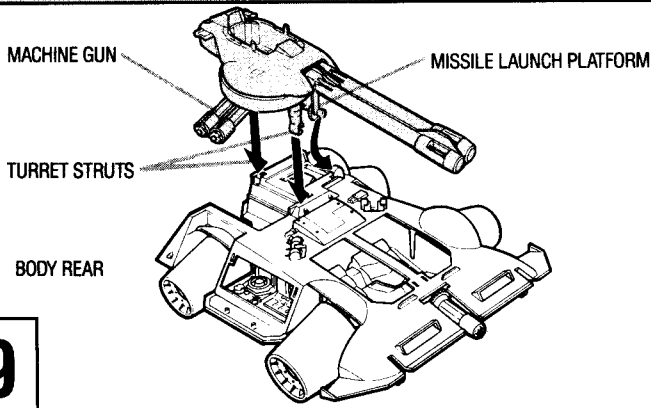

BUMPER RAM ASSEMBLY

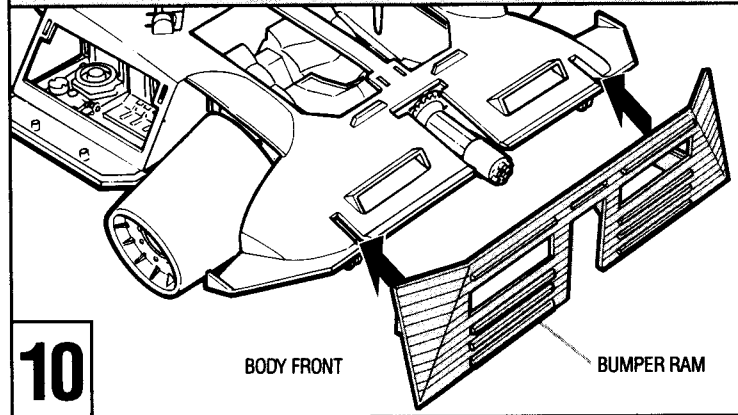

ENGINE HATCH INSTALLATION

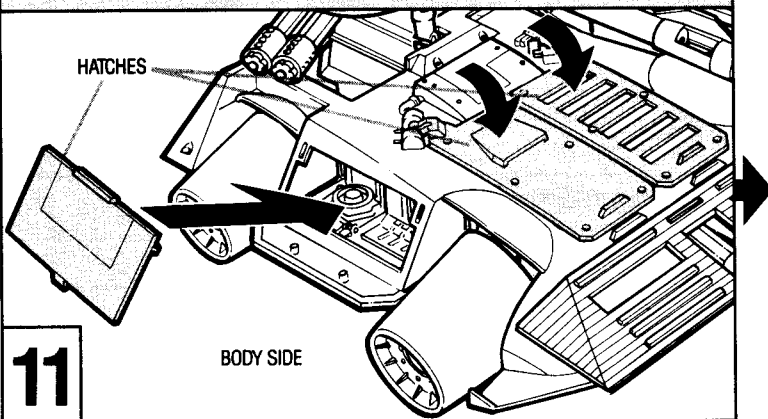

ROCKET POD ASSEMBLY/INSTALLATION

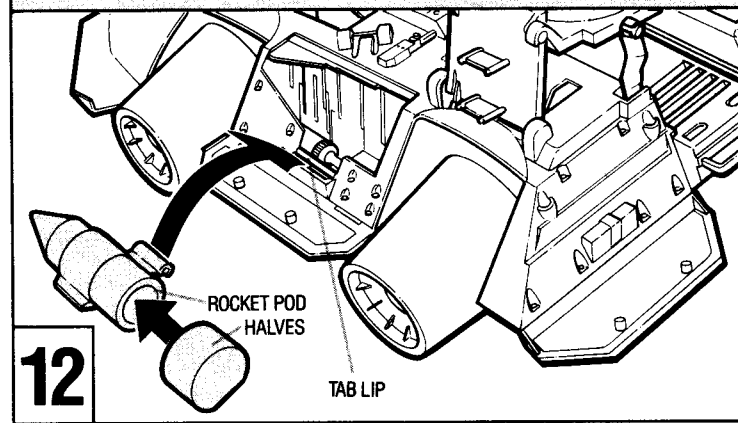

HAND RAIL INSTALLATION

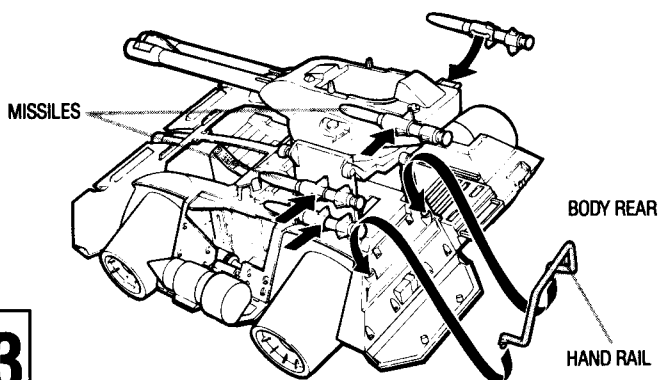

- 7 Snap front and rear elevating struts onto posts on turret as shown. (ILL. 7)
- 8 Snap missile launch platform onto turret side. (ILL. 8)
- 9 Fit turret struts and missile launch platform into grooves on body as shown. To place into battle position, lift up turret as shown. To lower turret, swing downward, making sure machine gun is facing rear of body. (ILL. 9)
- 10 Fit bumper ram into notches in body front end. To activate pivot bumper ram upwards. (ILL. 10)
- 11 Snap hatches over openings on body top and right body side. (ILL. 11)
- 12 Snap rocket pod halves together, then snap onto tab lip on left body side. (ILL. 12)
- 13 Snap hand rail into holes in body rear. Fit missiles onto tabs on missile launch platform. (ILL. 13)

Peel and apply labels as shown.

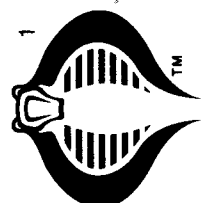
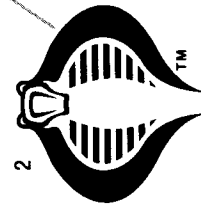
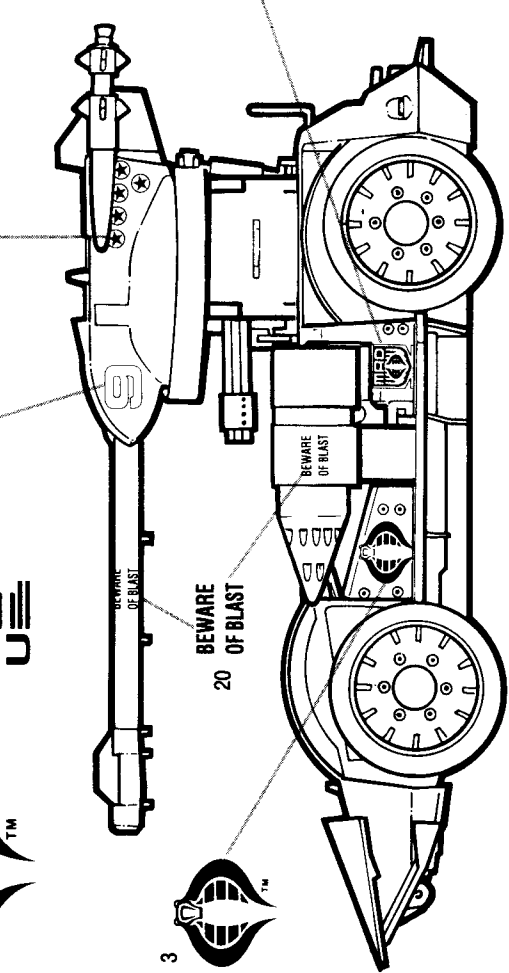
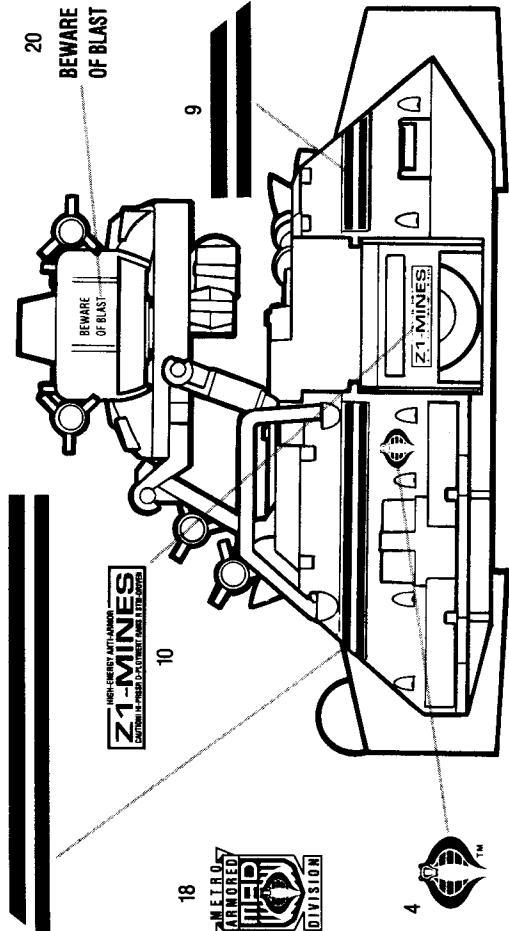
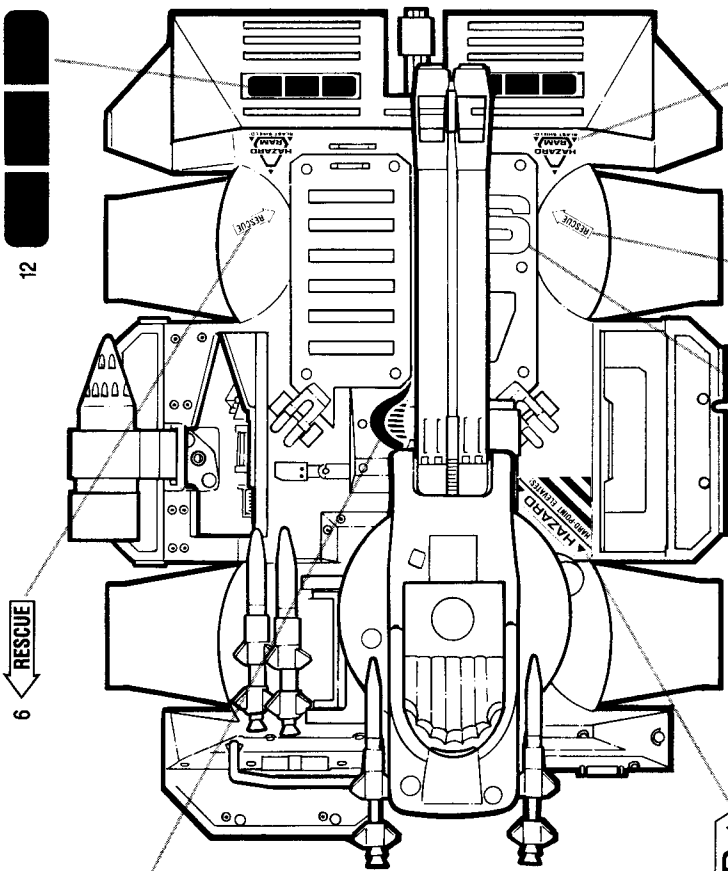

20 BEWARE OF BLAST



16 Place onto cockpit dashboard.

5 PANEL REMOVAL



PANEL REMOVAL



12

6 RESCUE

1

20

19

16

5

11

3

2

15

17

21

14

7

13

8

9

10

18

4

20

COBRA™ RAGE™

- 1) TITANIUM REINFORCED, REAR TURRET, STABILIZER SECTION
- 2) LASER COMPUTER GUIDED, AIR-TO-AIR FULL BLAST MISSILES
- 3) LOW-LINED, SIDEWALL, STABILIZING WINGLETS
- 4) FULL ROTATING, MULTI-SHOT, HIGH-INTENSITY MACHINE CANNON
- 5) BLAST PROOF, AERODYNAMIC, PROGRAMMABLE CANNON TURRET
- 6) REMOTE, SWING-DOWN, BURST ACTIVATED PROJECTILE LAUNCHER
- 7) LONG RANGE, DUAL BARRELED, CONCUSSION CANNON
- 8) HYDRO-CHARGED, MULTI-PORT, 25 VALVE THRUSTER ENGINE
- 9) POSITIONABLE, RAMMING SPEED, BATTERING RAM DEFENSE SYSTEM
- 10) FULL ROTATING, FRONT MUZZLE CANNON

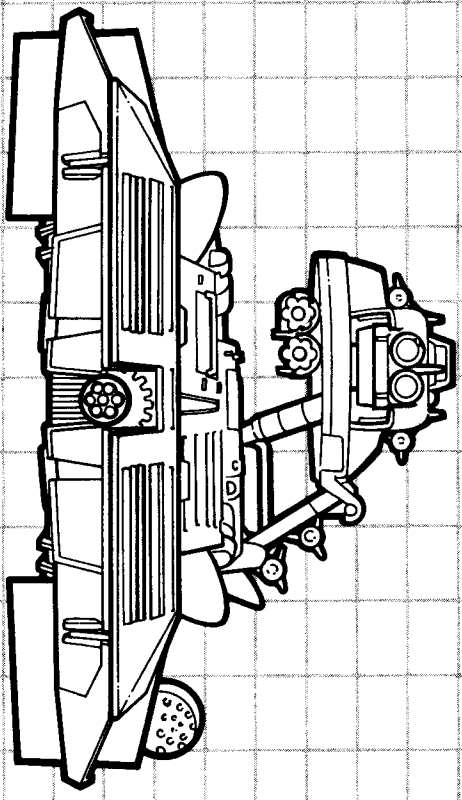

(10)

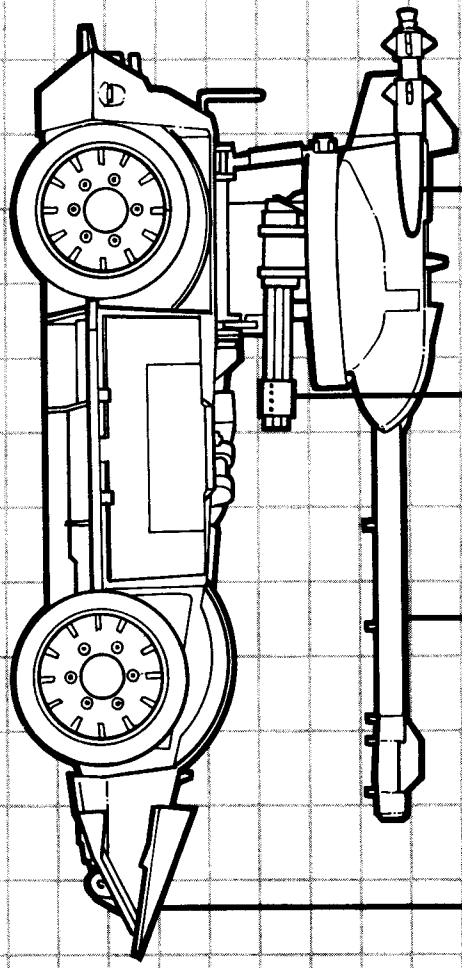
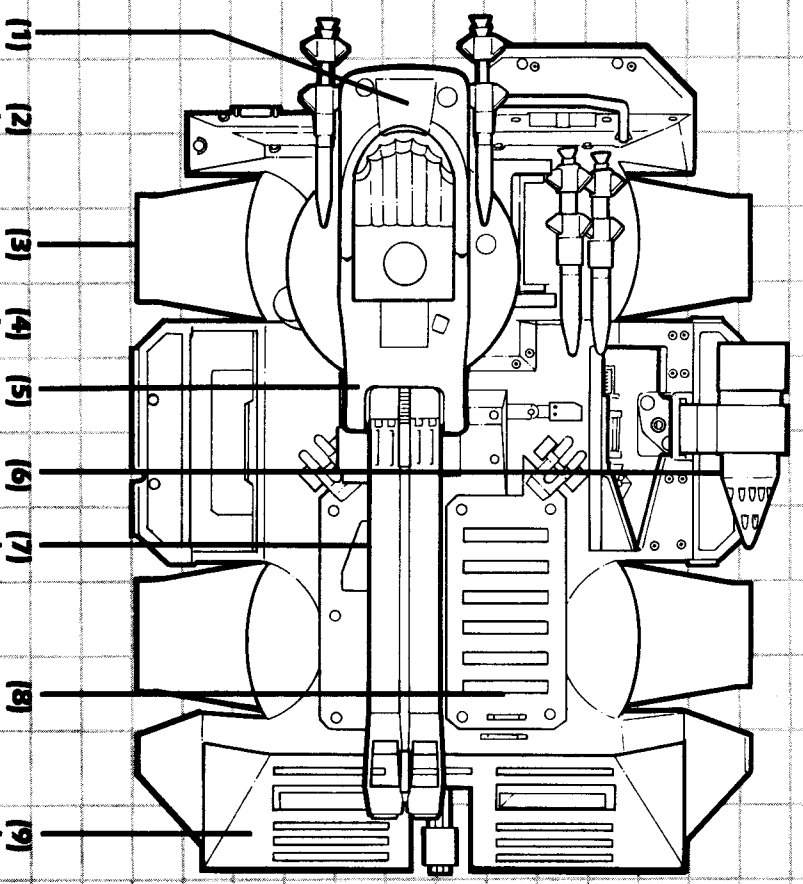

(10)