

PLAYSKOOL
Ride-ons

Ages 3-8
Weight limit: 70 lbs

THE REAL GHOSTBUSTERS™ 16" Power Cycle®

#50545

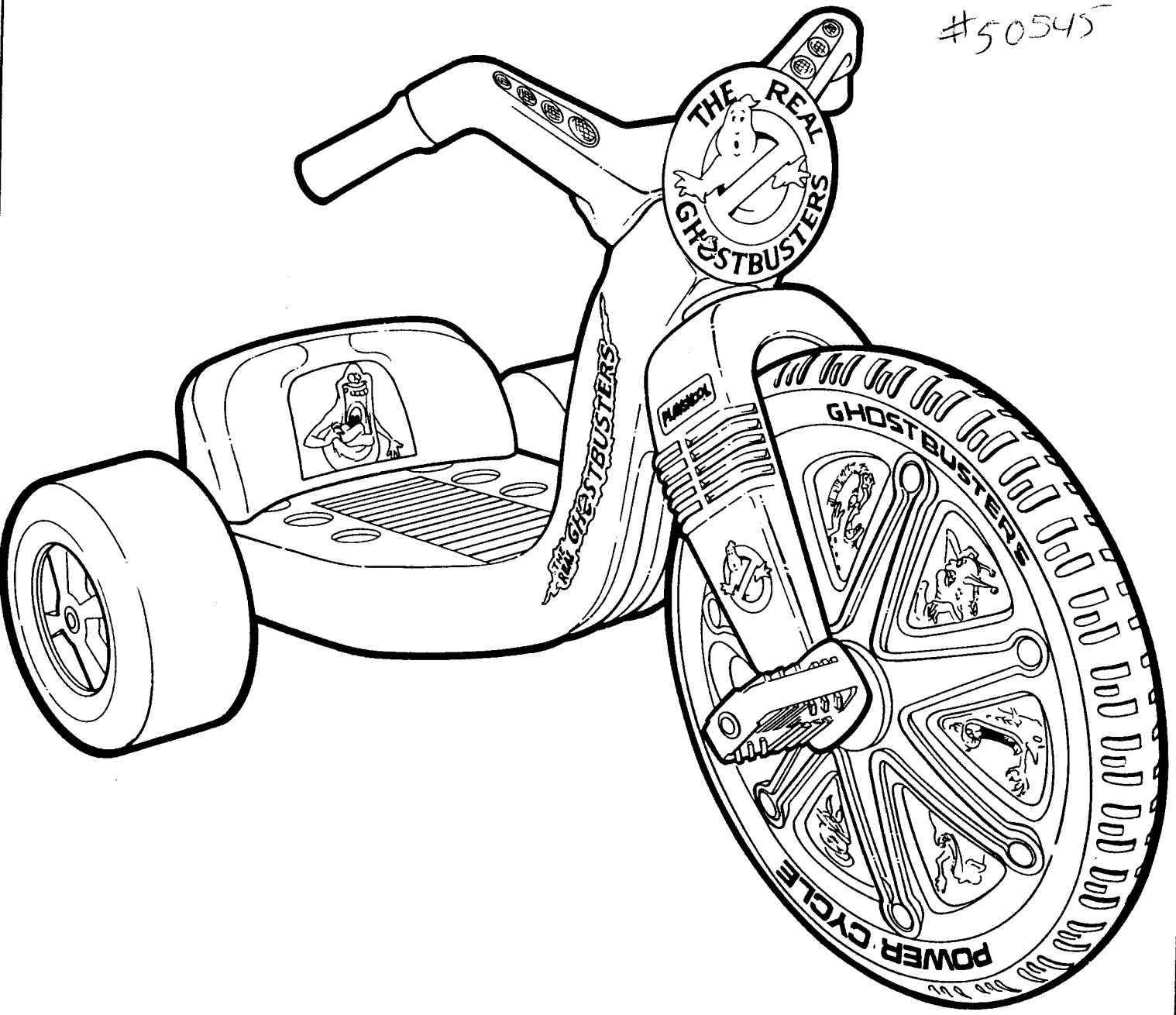

PLEASE NOTE: THIS PRODUCT SHOULD BE ASSEMBLED BY AN ADULT. PLEASE READ INSTRUCTIONS PRIOR TO ASSEMBLY. STUDY EACH STEP CAREFULLY TO FAMILIARIZE YOURSELF WITH PROCEDURE AND PARTS (REFER TO BACK PAGE FOR ILLUSTRATED PARTS LIST).

TOOLS REQUIRED (NOT INCLUDED) Hammer, Phillips head screwdriver and a small block of wood (approx. 2" x 2" x 3/4").

CAUTION: ADULT SUPERVISION AND INSTRUCTION REQUIRED REGARDING THE PROPER USE OF THIS TOY. THIS RIDE-ON TOY SHOULD NOT BE USED NEAR SWIMMING POOLS, ON OR NEAR HILLS, ROADWAYS, SLOPED DRIVEWAYS, ALLEYS OR STEPS. SHOES MUST BE WORN AT ALL TIMES. ONLY ONE RIDER AT A TIME. DO NOT RIDE AFTER DARK. DO NOT CARRY ANYTHING, PARTICULARLY OBJECTS THAT IMPAIR VISION, WHILE RIDING THIS TOY.

ADULTS PLEASE NOTE
PERIODICALLY CHECK ALL HARDWARE
TO BE SURE IT IS SECURE

ASSEMBLY INSTRUCTIONS

STEP 1. REAR WHEEL ASSEMBLY

1A) Place rear axle on small block of wood as shown. Position palnut over top end of axle. Fit palnut tool over nut. Using hammer, tap palnut onto end of axle.

1B) Slide axle through hole in spoked side of rear wheel. Slide clicker onto axle as shown. Slide axle through hole in rear of cycle and fit clicker into body as shown.

1C) Slide second clicker onto axle and into body as shown. Slide other rear wheel over end of axle, so that spokes on wheel face out.

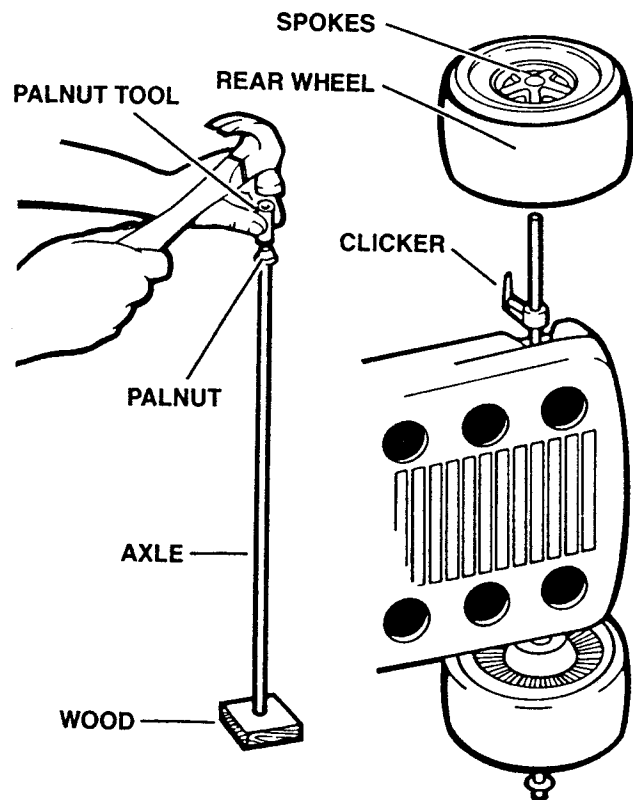

NOTE: For easier assembly, trim excess plastic from all parts before starting.

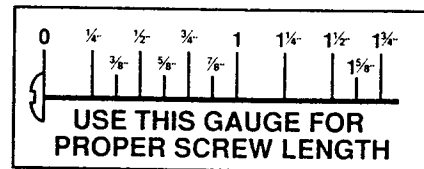

STEP 2. REAR WHEEL/BODY ASSEMBLY

Stand cycle on its side, with open end of axle pointing up. Place block of wood under other end of axle. Fit palnut over open end of axle. Fit palnut tool over palnut. Using hammer, tap palnut onto end of axle.

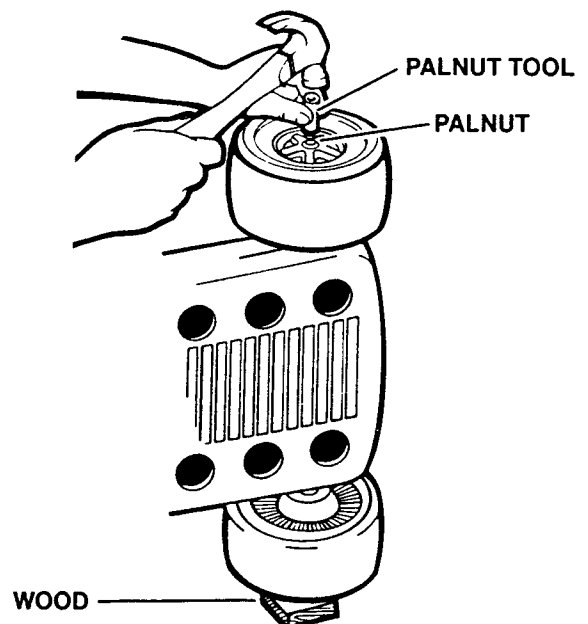

STEP 3. FRONT PEDAL ASSEMBLY

Slide pedal over end of pedal crank-shaft. NOTE: The flat end of the pedal should be facing in, and the rounded corners should be pointing out as shown. Fit palnut over end of crank shaft.

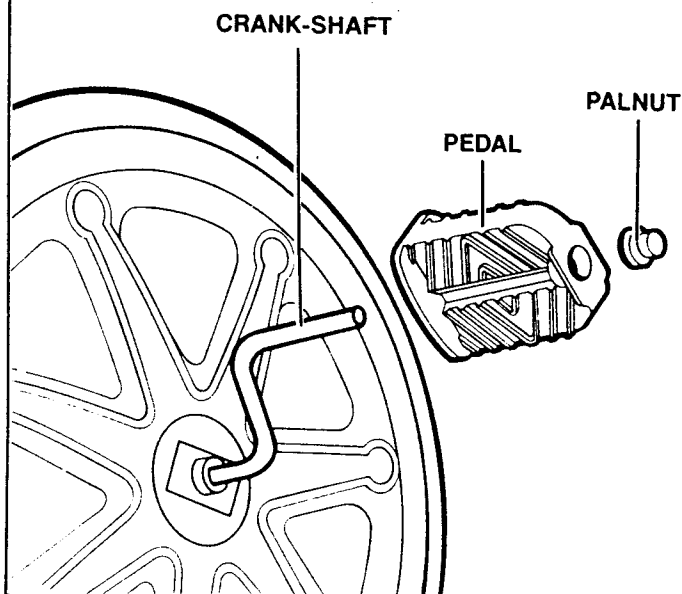

STEP 4. FRONT PEDAL ASSEMBLY (CONT.)

Place block of wood under other end of crankshaft for support as shown. Fit palnut tool over palnut. Using hammer, tap palnut onto end of axle. Repeat Steps 3 & 4 with other side of crank-shaft and other pedal.

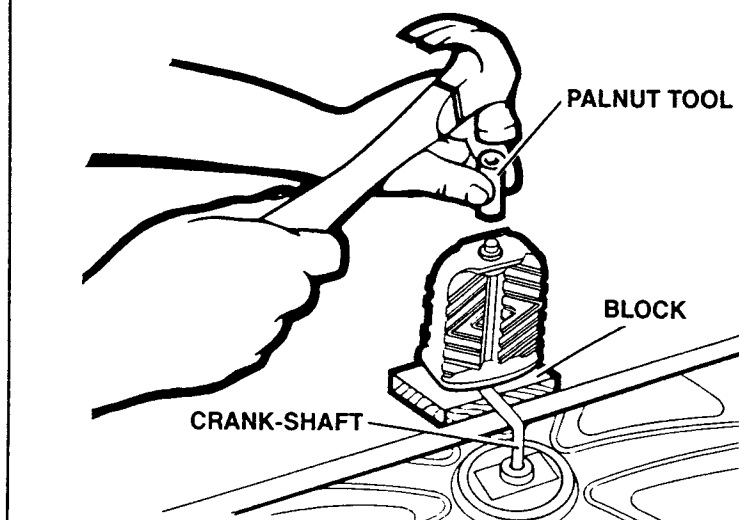

STEP 5. FORK & WHEEL ASSEMBLY

Fit front wheel axle into grooves in front fork.

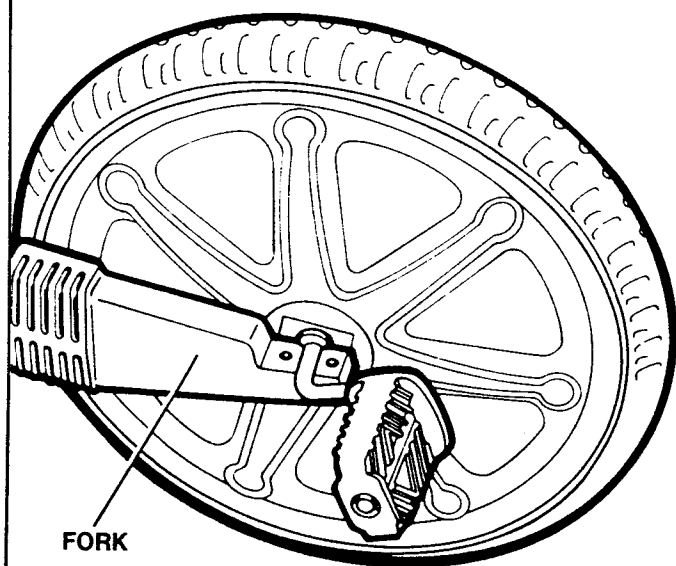

STEP 6. FORK & WHEEL ASSEMBLY (CONT.)

Place axle cap over one end of axle as shown. Line up holes in axle cap with holes in fork. Fit 1" screw into top hole in axle cap and tighten, using Phillips head screwdriver. Fit 5/8" screw into bottom hole in axle cap and tighten, using a Phillips head screwdriver. DO NOT OVERTIGHTEN SCREWS. Repeat step with other axle cap and screws.

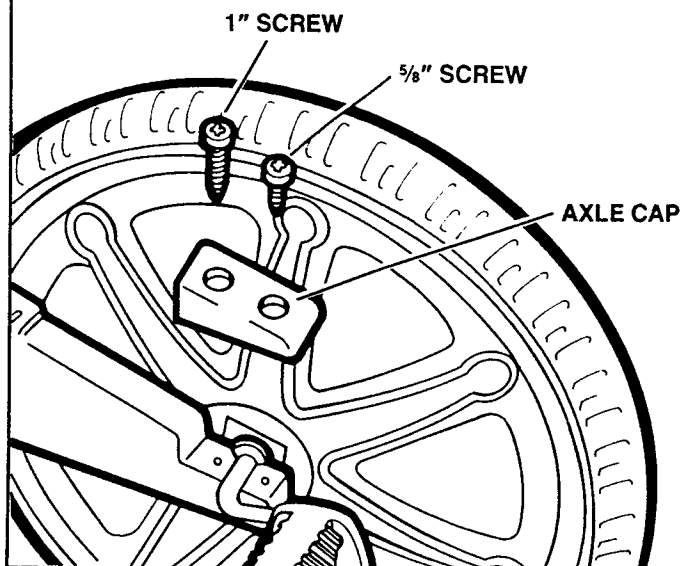

STEP 7. HANDLEBAR ASSEMBLY

Insert post on fork through hole in front of body. Slide handlebars over post on fork. **IMPORTANT NOTE:** The axle caps and the handlebar handles should be facing the rear of the cycle.

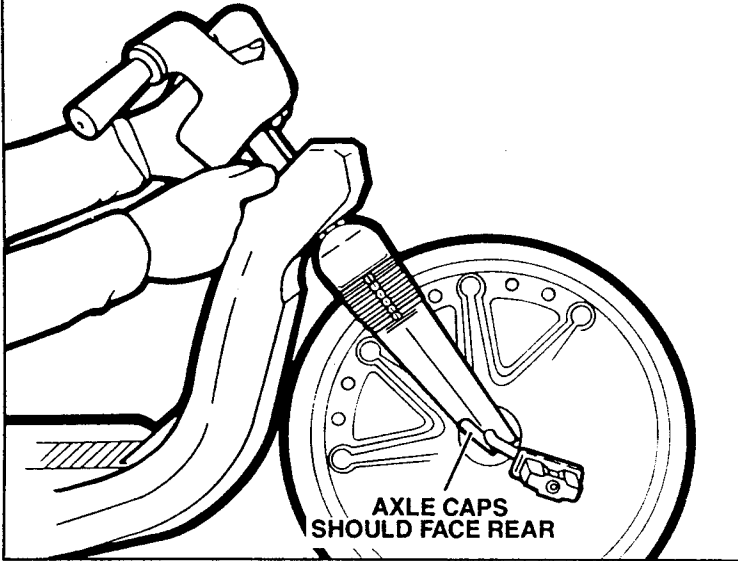

STEP 8. HANDLEBAR ASSEMBLY (CONT.)

Turn cycle upside down. Push down on fork and fit two 1 1/2" screws into holes in handlebars. Tighten screws, using Phillips head screwdriver. **DO NOT OVER-TIGHTEN SCREWS.**

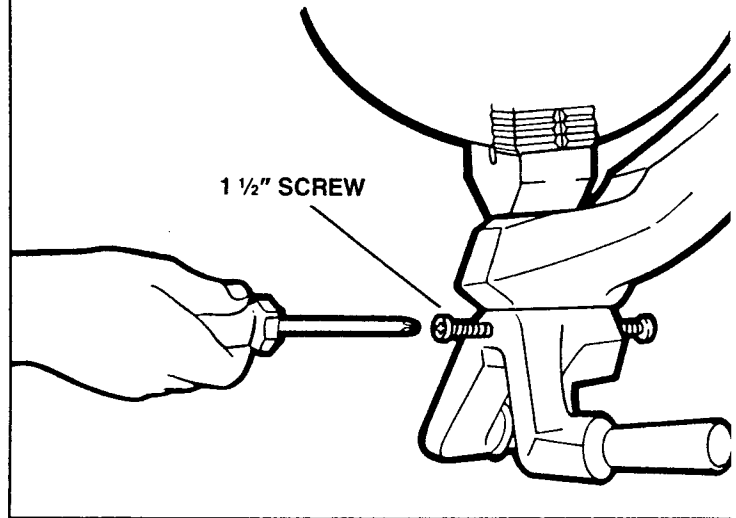

STEP 9. PLAQUE ASSEMBLY & DECAL APPLICATION

Wipe plaque with clean, dry cloth. Make sure holes are at bottom of plaque. Remove decal from decal sheet and apply to plaque as shown. Line up holes in plaque with holes in body. Fit two 5/8" screws through decal and into holes in body. Tighten screws using a Phillips head screwdriver. **DO NOT OVER-TIGHTEN SCREWS.** (ILL.9)



— DECAL

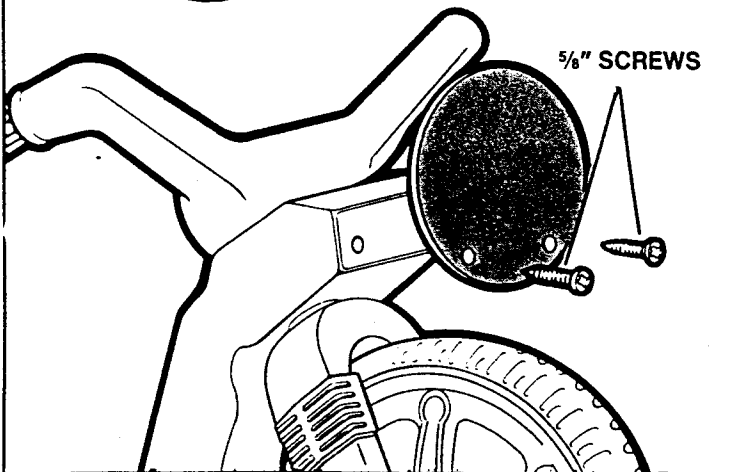

STEP 10. SEAT ASSEMBLY

Insert posts on seat rest into holes in body as shown. **NOTE:** You can adjust the seat to 3 different positions. Be sure your child's feet rest firmly on the pedals when riding this toy.

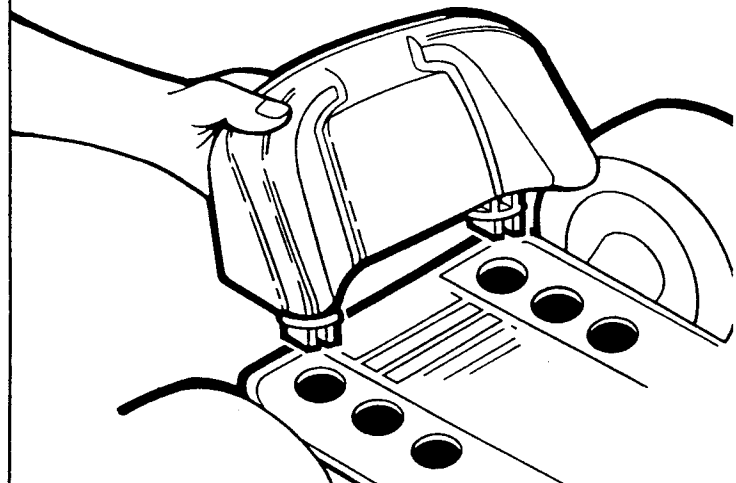

STEP 11. DECAL APPLICATION

IMPORTANT:
DECALS HAVE QUICK-SETTING ADHESIVE, BE SURE
OF DECAL PLACEMENT BEFORE APPLYING. DECALS
CANNOT BE LIFTED AFTER SETTING.

NOTE: Thoroughly wipe decal areas clean with dry cloth
before applying decals.

Peel decals from decal sheet one at a time. Apply decals to
appropriate positions on ride-on as shown. NOTE: For best
results, be sure all decals are positioned on cycle exactly as
shown.

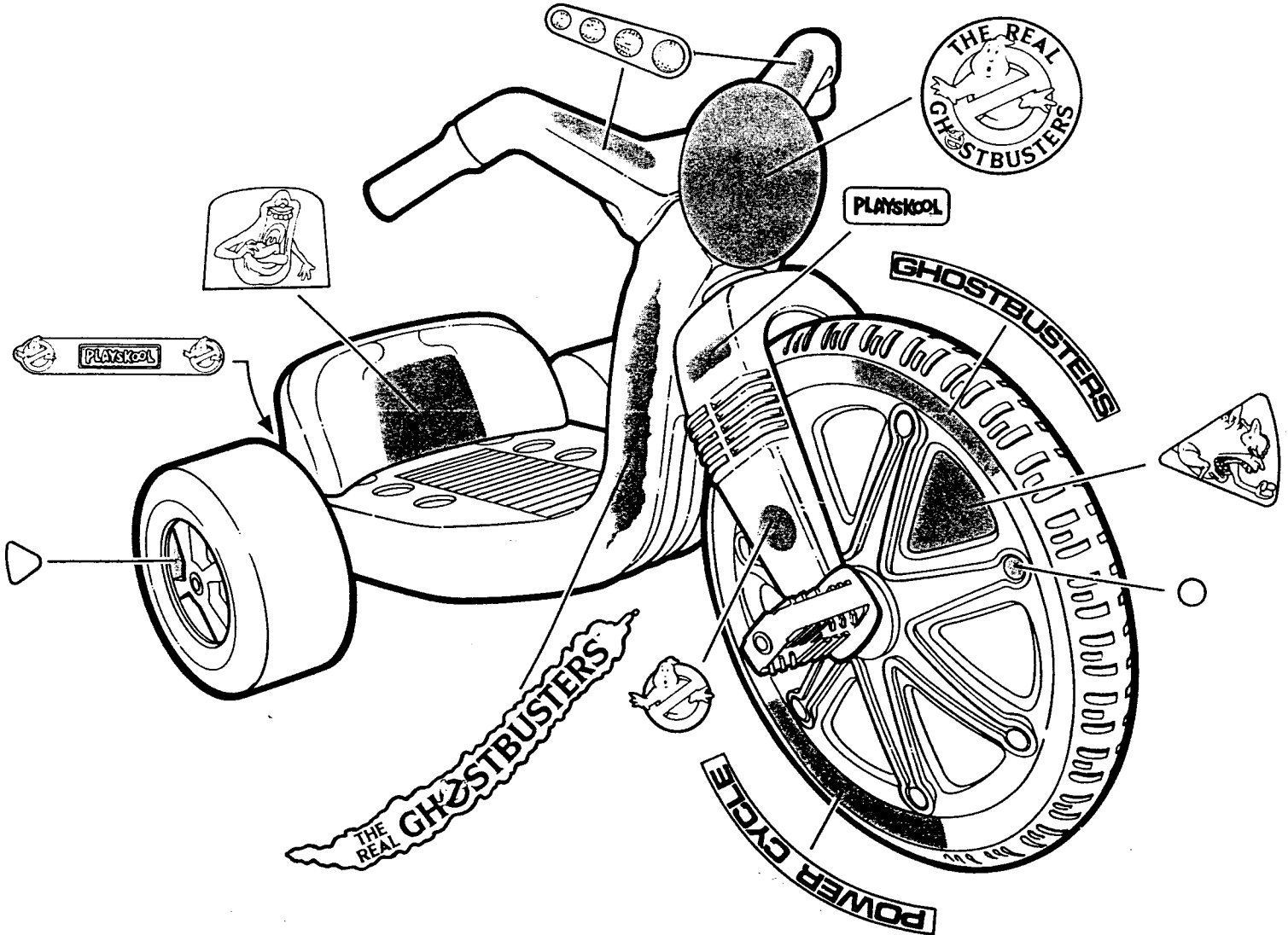
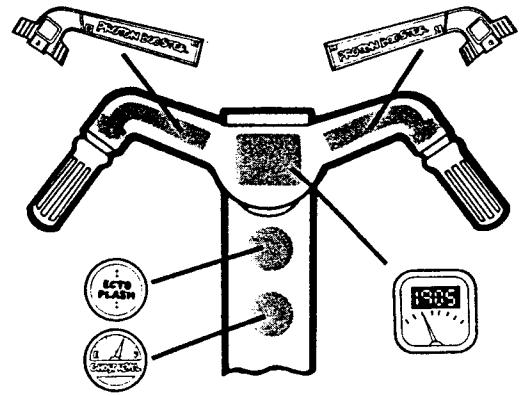

Replacement Parts Order Form

GH^{OST}BUSTERS™

16" Power Cycle® Ride-on Model 50545

Please check all parts carefully before assembly.

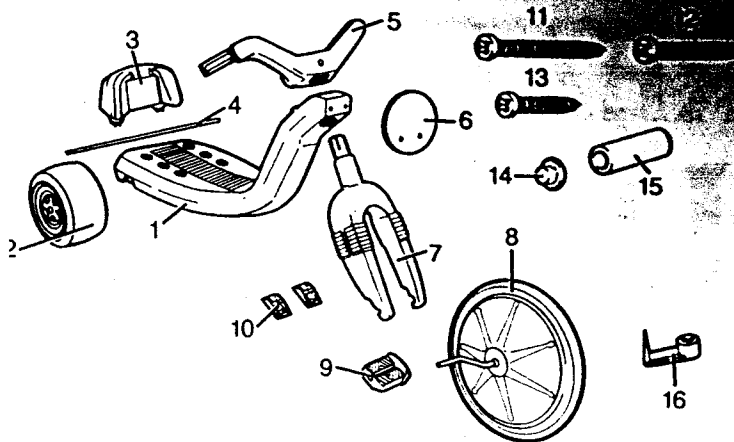

- | | |
|--------------------|-----------------------------|
| 1. BODY | 10. AXLE CAPS (2) |
| 2. REAR WHEELS (2) | 11. 1½" SCREWS (2) |
| 3. SEAT REST | 12. 1" SCREW |
| 4. REAR AXLE | 13. ¾" SCREWS (4) |
| 5. HANDLEBARS | 14. PALNUTS (4) |
| 6. PLAQUE | 15. PALNUT TOOL |
| 7. FRONT FORK | 16. CLICKERS (2) |
| 8. FRONT WHEEL | 17. DECAL SHEET (NOT SHOWN) |
| 9. PEDALS (2) | |

PLEASE NOTE: If you have any questions or comments concerning this product, call our Playskool Consumer Service hotline at 1-800-237-0063 Monday through Friday, 8:30 AM to 4:30 PM Eastern Standard Time. In Rhode Island, call 431-8697.

All Written inquiries should be mailed to:
Playskool Consumer Service Division, P.O. Box 5839, Pawtucket, Rhode Island 02862
This will provide you with quick and reliable service for your product.
Do not request the same from the store where you bought this toy.

PART NO.	DESCRIPTION	KIT NO.	QUANTITY	PRICE	TOTAL
2	2 Rear Wheels	40282900		\$1.80	
	1 Seat Back	40282606		1.10	
	1 Rear Axle	40282800		1.00	
5	1 Set of Handlebars	40282504		2.40	
7	1 Set of Front Forks	40282704		1.75	
8	Front Wheel with Crank-Shaft	40284700		7.60	
9, 15	2 Pedals with 2 Palnuts	40283106		1.50	
10	Axle Cap Kit	Kit 1006		1.00	
12, 13, 14, 15 & 16	Hardware Bag — (2) 1½" Screws, (2) 1" Screws, (4) ¾" Screws & (4) Palnuts	Kit 1004		3.25	
6, 17	Decal Sheet & Plaque	Kit 990		3.10	

HERE'S HOW TO ORDER:

Fill out the shipping label below. Print clearly in ink, as label will be applied to the outside of your package for shipping. Be sure to include your ZIP code.

Fill in the information requested on the order form.

Enclose it with your shipping label, check or money order (NO CASH OR STAMPS, PLEASE) made payable to: **PLAYSKOOL**

Mail it to:

PLAYSKOOL® CONSUMER SERVICE
P.O. Box 5839
PAWTUCKET, RI 02862

C.O.D. orders accepted.

We reserve the right to substitute parts whenever necessary. Parts and prices are all subject to change.

MERCHANDISE TOTAL	
STATE TAX (RI, NY & PA residents please add 6% sales tax to your order)	
SHIPPING & HANDLING	3.00
TOTAL	



PLAYSKOOL® CONSUMER SERVICE
P.O. Box 5839
PAWTUCKET, RI 02862

SHIP TO:

NAME _____
STREET _____
CITY _____ STATE _____
ZIP _____ COUNTY _____

GH^{OST}BUSTERS™

16" Power Cycle® Ride-on Model 50545

FOR OFFICE USE ONLY

DATE REC'D. _____
AM'T. REC'D. _____
REC'D. BY _____
DATE SHIPPED _____
VIA _____
NOTES _____

© 1984 Columbia Picture Industries, Inc.
© 1986 CPT Holdings, Inc. All Rights Reserved.
Manufactured under license by Playskool, Inc., Pawtucket, RI 02862
USA a subsidiary of Hasbro, Inc. Authorized User.
PRINTED IN U.S.A.

POSTMASTER: CONTENTS MERCHANDISE • RETURN POSTAGE GUARANTEED
MAY BE OPENED FOR POSTAL INSPECTION IF NECESSARY.