

AGES 8+

 **i-Dog's™**
beggin' for the beat™
pup

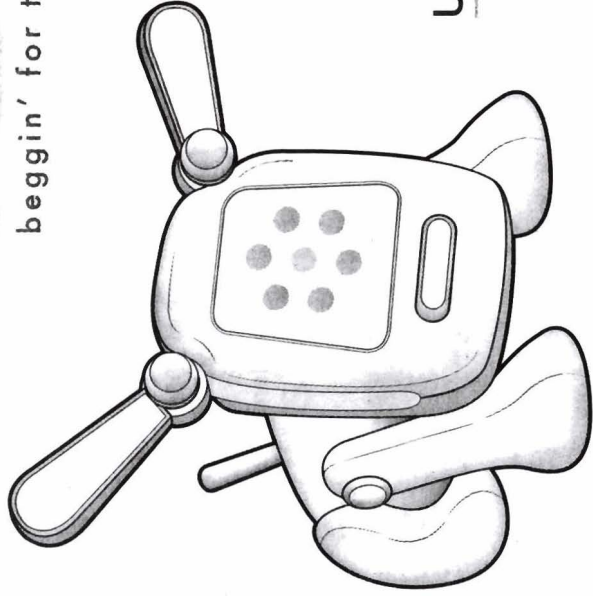

USER'S GUIDE

Thank you for purchasing I-DOG PUP.
Be sure to read and follow all instructions carefully before using this product.

I-DOG PUP moves and grooves, and displays light animations to the beat of the music he hears. This dog's got music skills. Turn off your music and he'll play 12 of his own riffs. I-DOG PUP loves to show you his moods – if your music's making him mellow, turn up your tunes!

X3 BATTERIES INCLUDED

Replace with 3 x 1.5V "AAA" or LR03 size alkaline batteries. Phillips/cross head screwdriver (not included) needed to replace batteries.

Getting To Know I-DOG PUP

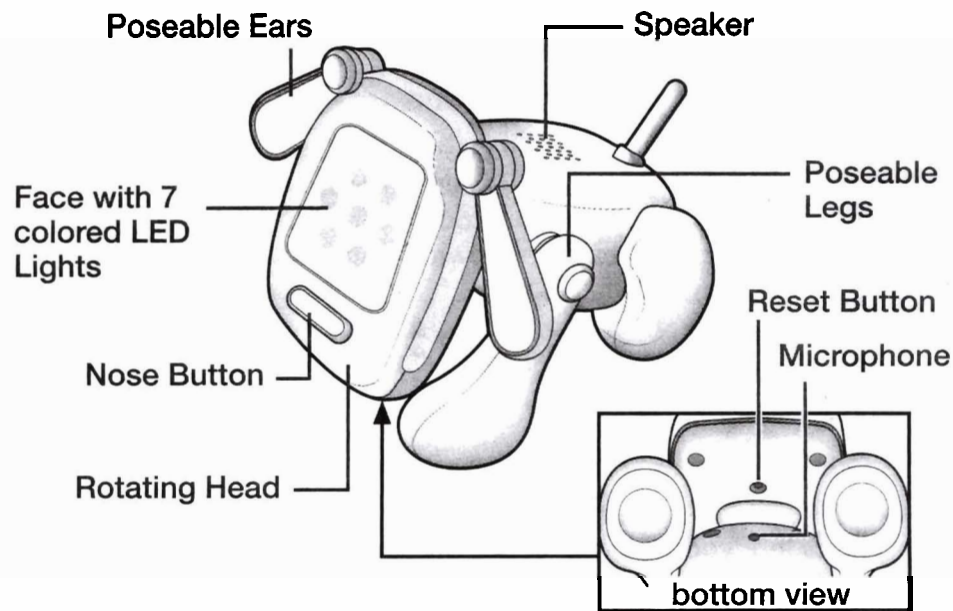

Which I-DOG PUP do you have?

Rock – Plays rock riffs and glows red.

Dance – Plays dance tunes and glows green.

Hip Hop – Plays hip hop beats and glows yellow.

Pop – Plays pop songs and glows orange.

To Replace Batteries

Using a Phillips/cross head screwdriver, loosen screw in battery compartment cover (screw stays attached to cover) on the center of I-DOG PUP's tummy. Insert 3 x 1.5V "AAA" or LR03 size alkaline batteries in the battery compartment. Replace cover and tighten screw.

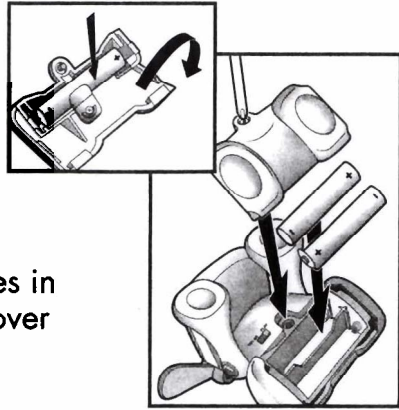

CAUTION:

- 1. As with all small batteries, the batteries used with this toy should be kept away from small children who still put things in their mouths. If they are swallowed, promptly see a doctor and have the doctor phone (202) 625-3333 collect. In other countries, have the doctor call your local poison control center.**
- 2. Make sure the batteries are inserted correctly and always follow the toy and battery manufacturers' instructions;**
- 3. Do not mix old batteries and new batteries or alkaline, standard (carbon zinc) or rechargeable (nickel-cadmium) batteries.**

IMPORTANT: BATTERY INFORMATION

Please retain this information for future reference.
Batteries should be replaced by an adult.

CAUTION:

- 1. Always follow the instructions carefully. Use only batteries specified and be sure to insert item correctly by matching the + and - polarity markings.**
- 2. Do not mix old and new batteries or standard (carbon-zinc) with alkaline batteries.**
- 3. Remove exhausted or dead batteries from the product.**
- 4. Remove batteries if product is not to be played with for a long time.**
- 5. Do not short-circuit the supply terminals.**
- 6. Should this product cause, or be affected by, local electrical interference, move it away from other electrical equipment. Reset (switching off and back on again or removing and re-inserting batteries) if necessary.**
- 7. RECHARGEABLE BATTERIES: Do not mix these with any other types of batteries. Always remove from the product before recharging. Recharge batteries under adult supervision. DO NOT RECHARGE OTHER TYPES OF BATTERIES.**
- 8. As with all small items, these batteries should be kept away from children. If swallowed, seek medical attention immediately.**

Getting Started

Your I-DOG PUP comes in "Try-Me" mode. Turn I-DOG PUP over and move the switch to "Play" mode.

NOTE: Only do this once: switching between "Try-Me" and "Play" mode resets I-DOG PUP to the default personality setting of "lonely and hungry."

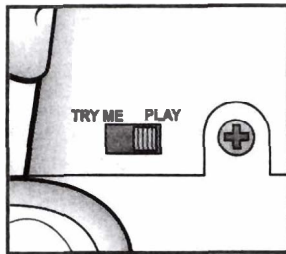

1. Once in "Play" mode, turn I-DOG PUP ON by pressing the Nose Button. I-DOG PUP will display a special LED light animation and sound to show you that he's awake and ready to play!
2. When you are finished playing with I-DOG PUP, press and hold down the Nose Button for at least 2 seconds to turn him OFF. I-DOG PUP will display an LED animation and make a sound to signal that he's going to sleep.

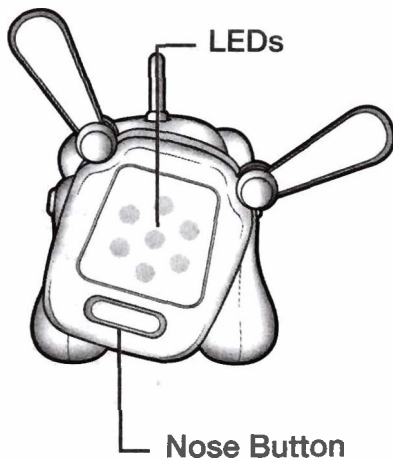

“Feed” I-DOG PUP Music

To keep I-DOG PUP satisfied and healthy, be sure to “feed” (play) him lots of music!

If I-DOG PUP is hungry and needs more music from you, his center LED will slowly pulsate yellow-green-yellow-green. The sequence will blink faster as he gets hungrier. When you see this happen, “feed” him some music!

If I-DOG PUP is lonely and needs more attention from you, his center LED will slowly pulsate red-orange-red-orange. The sequence will blink faster as he gets more desperate for your attention. When you see this happen, press his Nose Button a few times to show him attention!

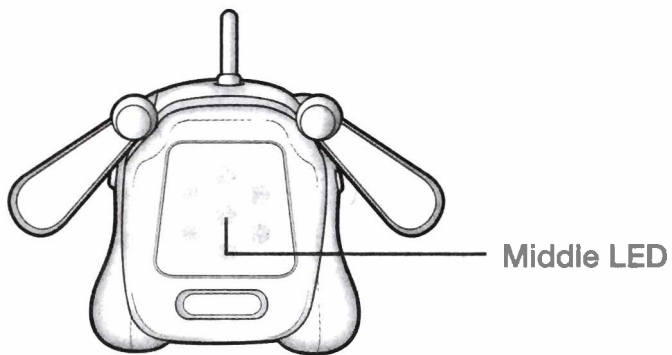

How to “Feed” I-DOG PUP

I-DOG PUP listens to music through its built-in Microphone. Simply place him near a speaker, where the volume is at a higher level, and watch him react! Observe his funky light patterns that pulse to the music he hears.

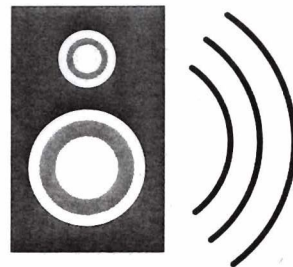

Give I-DOG PUP Lots of Love and Attention

To keep I-DOG PUP happy, be sure to give him plenty of love and attention. Press his Nose Button and he will make a scratching sound effect while displaying a spinning LED light pattern. Double-click his Nose Button quickly and repeatedly to hear music and see LED patterns that represent what mood I-DOG PUP currently has. If I-DOG PUP whines instead of playing a musical riff in return, that means he has become sick from not getting enough music and attention.

Moods

When music is not being played, double-click the Nose Button and I-DOG PUP will show you a mood.

I-DOG PUP changes his moods based on how much love and attention you give him (or don't give him) and how much music you've played for him. You can tell what kind of mood he's in from listening to the sounds he makes and the LED light patterns he displays.

When you're done "feeding" I-DOG PUP (no music is playing), double-click the Nose Button and pay attention to the light patterns I-DOG PUP displays to determine what mood he's in.

EXCITED

This means that you're "feeding" I-DOG PUP lots of music and giving him a lot of love and attention. You're pressing his nose so much he's excited. When you double-click his nose, he'll play excited music and show you the following light sequence:



NOTE - this light sequence moves quickly

HAPPY

This means that you're "feeding" I-DOG PUP enough music and giving him the right amount of love and attention. When you

double-click his nose, he'll play happy music and show you the following light sequence:

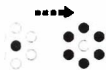

LONELY

This means that I-DOG PUP really needs to be "fed" more music and shown more love and attention! Be sure to press his nose and play him some more music! When you double-click his nose, he'll play lonely music and show you the following light sequence:

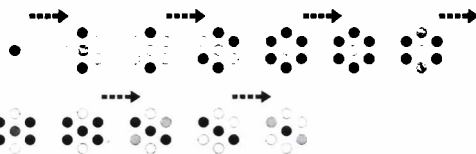

SAD

This means that you've left I-DOG PUP alone for too long. He needs more music and attention soon, or he may get sick! When you double-click his nose, he'll play sad music and show you the following light sequence:

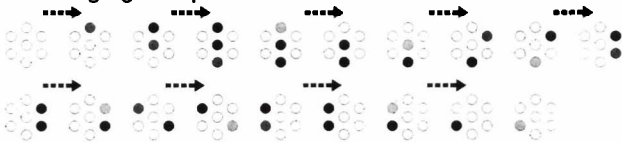

Important Tips

1. If you are not playing with I-DOG PUP, please remember to press and hold down the Nose Button for at least 2 seconds to turn him OFF. This will help conserve battery life.
2. If you do not interact with I-DOG PUP for one hour, he will automatically shut off.
3. I-DOG PUP may react to other sounds or noises that he hears, other than music.

Troubleshooting Guide

What to do if:

I-DOG PUP Freezes Up	Press the Reset Button using a pen tip.
I-DOG PUP Begins Acting Erratically	Change the batteries.

FCC STATEMENT

This device complies with part 15 of the FCC Rules. Operation is subject to the following two conditions: (1) This device may not cause harmful interference, and (2) this device must accept any interference received, including interference that may cause undesired operation.

This equipment has been tested and found to comply with the limits for a Class B digital device, pursuant to Part 15 of the FCC Rules. These limits are designed to provide reasonable protection against harmful interference in a residential installation.

This equipment generates, uses and can radiate radio frequency energy, and, if not installed and used in accordance with the instructions, may cause harmful interference to radio communications. However, there is no guarantee that interference will not occur in a particular installation. If this equipment does cause harmful interference to radio or television reception, which can be determined by turning the equipment off and on, the user is encouraged to try to correct the interference by one or more of the following measures:

- Reorient or relocate the receiving antenna.
- Increase the separation between the equipment and the receiver.
- Consult the dealer or an experienced radio/TV technician for help.

Product and colors may vary.



© 2005 Hasbro. All Rights Reserved. TM & ® denote U.S. Trademarks.



76316
PN 6588780000