

AGES 8+
71970

LAZER TAG

TEAM OPS™

Deluxe 1 Player System

Thank you for purchasing the LAZER TAG Deluxe 1 Player System. Please be sure to read and follow all instructions carefully before using this product.

Includes 1 Tagger™* Unit, 1 HUD™* Unit, 1 Connector Cable, Stickers & Instructions.

Requires 6 x 1.5V "AA" or LR6 size alkaline batteries (not included).
Phillips/cross head screwdriver (not included) needed to insert batteries.



Tiger®* recommends
ENERGIZER® batteries for
ideal performance.

FIND 6 HIDDEN LAZER TAG [CODES]
THROUGHOUT THIS BOOK.

Log-on to lazertag.com and enter your
codes to unlock secret bonus game
strategies!

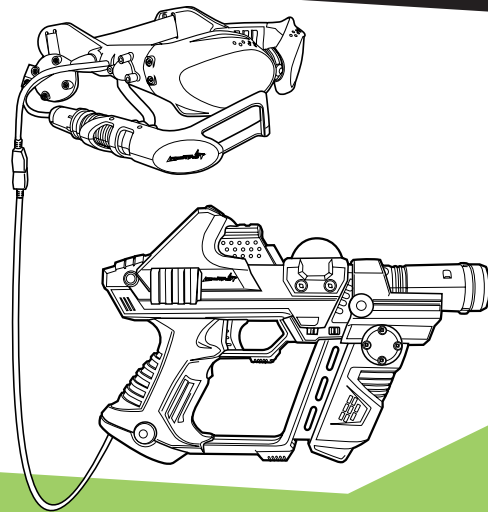

CAUTION: Do not look directly at the sun.

NOTE: Not for nighttime play.

TABLE OF CONTENTS

Quick Start Guide.....	1	Ending Games Early	17
Introduction.....	2	11 Pre-Programmed Games	18
Battery Installation Information.....	3	Classic Lazer Tag [®] /Custom Lazer Tag [®]	18
Tagger™* Unit Illustration.....	4	2 and 3 Team Custom Lazer Tag [®]	18
TAGGER Buttons.....	5	Hide and Seek	19
LCD Screen.....	5	Hunt the Prey	20
HUD™* (HEADS UP DISPLAY) UNIT Illustration.....	6	2 and 3 Kings.....	20
How to Connect your TAGGER to the HUD (HEADS UP DISPLAY)	7	Zone Games	21
To Wear the HUD	8	Own the Zone	22
Lazer Tag [®] Code Of Conduct.....	8	Energizer Coupon.....	23
Lazer Tag [®] Game Features	9	2 and 3 Teams Own the Zone	25
Medic Mode.....	11		
Programmable Games.....	12		
How to Host a Game.....	13		
How to Join a Game	15		
End of Game Debriefing and Scoring.....	16		

QUICK START GUIDE

For a quick, “Grab & Go” game of Lazer Tag®, simply follow these steps:

1. Press the TRIGGER to wake your TAGGER up.
2. Verify that the power-up SFX are played, and “LTAG” appears on the LCD screen.
3. Press the Trigger to start the Classic LAZER TAG “LTAG” game. All players should press their triggers together, so that everybody starts at the same time.
4. The LCD Screen will display a 10-second countdown during which time the players should take their desired positions.
5. At T-0 the TAGGER will say “GOOD LUCK” and the game will begin.
6. Aim and get tagging!

The Classic LAZER TAG game is an “individuals” game, which means that all other players are your opponents. The winner is the last player not tagged out. Each player has unlimited reloads, 10 Mega-Tags, 15 seconds of shields, and is tagged out after receiving 10 tags from other players.

After a player is tagged out, their Game Time will continue to run for another 2 minutes and the number of minutes and seconds which they lasted before being tagged out will be shown below the Game Time. Any player who has cheated by restarting their TAGGER in mid-game will have a much lower Game Time than anyone else, so players can check each others’ timers to ensure no player has done this.

A TAGGER will go to sleep if there is no activity for two minutes after being tagged out. To maintain your game timer longer than this, press OK once a minute or so until the game is over for all players, then you can compare timers.

Classic LAZER TAG is not a Hosted game, so it does not require Hosting and Joining the way the other more advanced games do. It also does not support Debriefing and Scoring at the end of the game.

To turn your TAGGER off, press 2nd F + CANCEL.

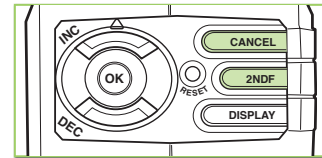

If you'd like to start another game, just press the TRIGGER.

IMPORTANT NOTE: When joining, hosting or debriefing, switch the Speaker On/Off Switch to Off [🔇].

HELPFUL HINTS

1. For Zone Games, set the Indoor/Outdoor Switch to “Outdoor” for a larger zone, or “Indoor” for a smaller zone.
2. During general use, the Indoor/Outdoor Switch should be set at “Outdoor.” If you experience stray or incidental tags when playing in an enclosed area, switch the Indoor/Outdoor switch to “Indoor” to minimize reflective signals.

TAGGER RIGHT SIDE VIEW

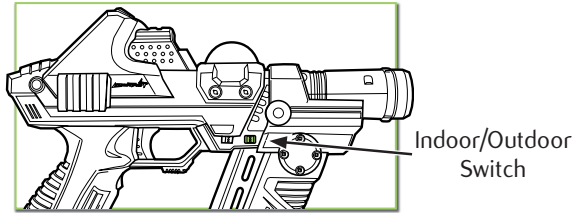

3. There are two sights on the left side of the Tagger™* Unit to assist in accurate launching of tags. Line up your target by using the two sights for increased accuracy in targeting.

TAGGER LEFT SIDE VIEW

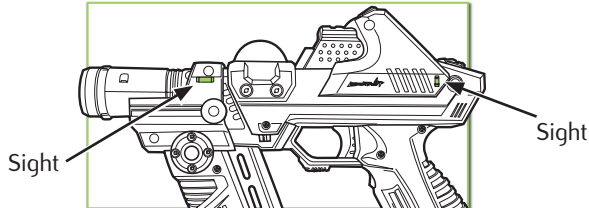

4. Tags can be registered from a distance, even if it exceeds your lock-on and verification capabilities. This means you can sometimes score a long distance tag without audio/visual verification. Even if your TAGGER is not locking on to its target, it is often worth attempting a long distance tag in excess of 100 feet using the manual sight alone.

Thank you for purchasing the Lazer Tag® Deluxe 1 Player System! Step into LAZER TAG – where video game action comes to life!™* LAZER TAG combines extreme team competition with hi-tech accuracy. Assemble your team and lead them into The Ultimate Game of Electronic Tag™* to become the Tag Master™*!

Please be sure to read and follow all instructions carefully before using this product. Before you can begin playing with your LAZER TAG Deluxe 1 Player System you must first install batteries.

Be the TAG MASTER!

Think you've got what it takes to be the TAG MASTER? Prove it by being the winner in your first game of LAZER TAG! Earn this title and you will have the privileges of being the host for every game!

TO INSERT BATTERIES

Using a Phillips/cross head screwdriver, loosen the screw in the battery compartment cover of each TAGGER (screw stays attached to cover). Remove cover. Insert 6 x 1.5V “AA” or LR6 size alkaline batteries. Replace cover and tighten screw.

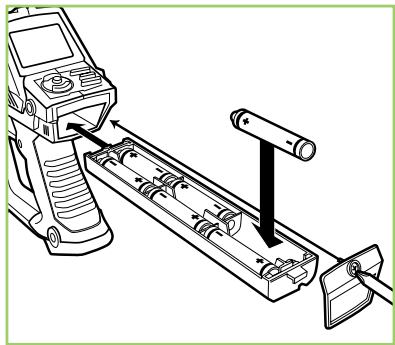

CAUTION: TO AVOID BATTERY LEAKAGE

1. Be sure to insert the batteries correctly and always follow the toy and battery manufacturers' instructions;
2. Do not mix old and new batteries or alkaline, standard (carbon-zinc) or rechargeable (nickel-cadmium) batteries;
3. Always remove weak or dead batteries from the product.

IMPORTANT: BATTERY INFORMATION

Please retain this information for future reference. Batteries should be replaced by an adult.



CAUTION:

1. Always follow the instructions carefully. Use only batteries specified and be sure to insert item correctly by matching the + and – polarity markings.
2. Do not mix old batteries and new batteries or standard (carbon-zinc) with alkaline batteries.
3. Remove exhausted or dead batteries from the product.
4. Remove batteries if product is not to be played with for a long time.
5. Do not short circuit the supply terminals.
6. Should this product cause, or be affected by, local electrical interference, move it away from other electrical equipment. Reset (switching off and back on again or removing and re-inserting batteries) if necessary.
7. **RECHARGEABLE BATTERIES:** Do not mix these with any other types of battery. Always remove from the product before recharging. Recharge batteries under adult supervision. **DO NOT RECHARGE OTHER TYPES OF BATTERIES.**

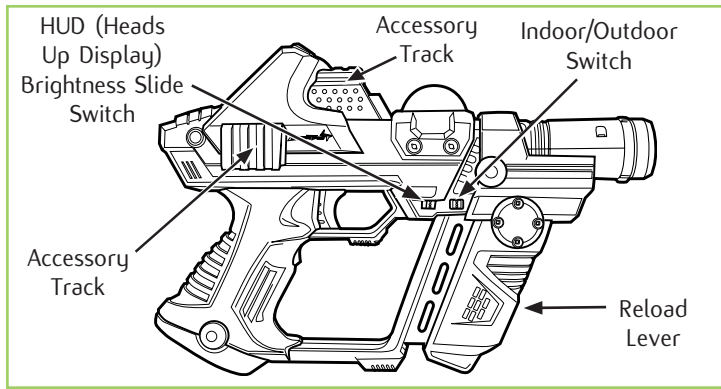

TAGGER RIGHT SIDE

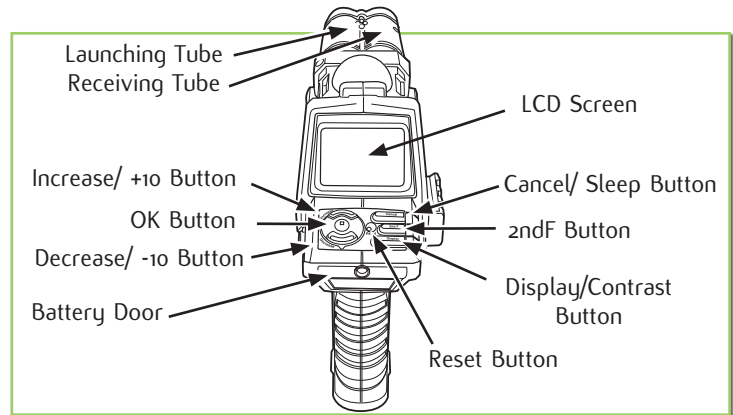

TAGGER REAR VIEW

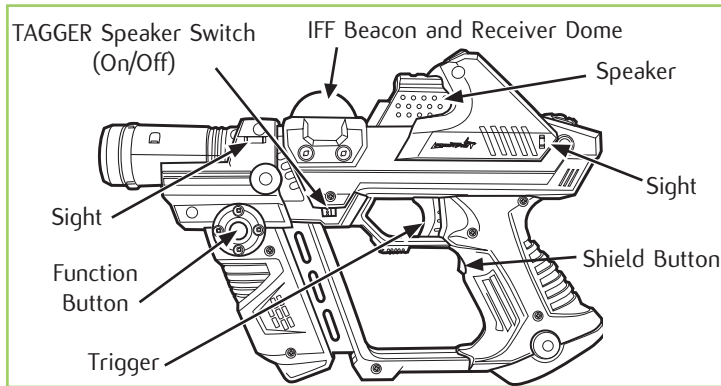

TAGGER LEFT SIDE

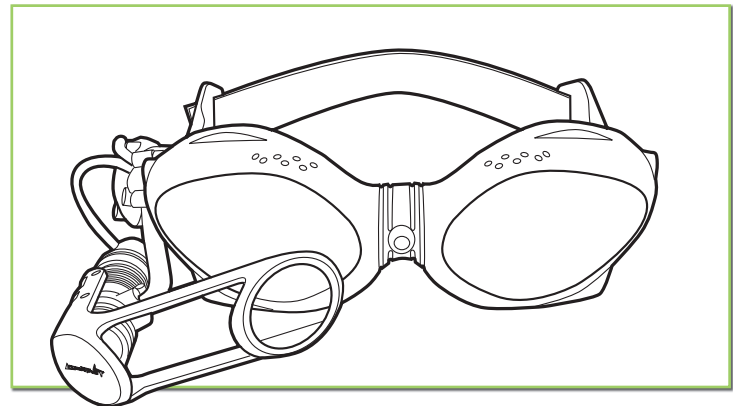

HUD (HEADS UP DISPLAY)

BUTTONS

The following buttons are used to enter information into your TAGGER before, during, and after the game. Each button has two functions: its Main Function and its Second Function.

2ndF: Hold this button down and quickly press then release any of the other buttons to perform that button's Second Function. Pressing and holding 2ndF for more than 2 seconds at any time during an actual game mutes or un-mutes the sound effects.

INC: Selects the next item in a list of options, or increases a number value by 1. Second Function: 2ndF + INC = Increases the number value by 10.

DEC: Selects the previous item in a list of options, or decreases a number value by 1. Second Function: 2ndF + DEC = Decreases the number value by 10.

OK: Enters the selected option or value. Second Function: Starts or ends the game immediately (only the Host can do this).

CANCEL: Cancels the value or option just selected and backs-up a step, or dismisses Medic-Mode requests. Second Function: 2ndF + CANCEL = Quits the game and turns the TAGGER off.

DISPLAY: Selects which set of data is to be displayed during

the game. Second Function: 2ndF + DISPLAY = Adjusts the LCD contrast.

FUNCTION: Selects the special modes for the Trigger and the Shield. Holding this button while pulling the Trigger adds Mega-Tag power to the next tag that you launch. Holding this button while pulling the Shield initiates Medic Mode.

INDOOR/OUTDOOR SWITCH: Decreases the intensity of the tag signal for use indoors so that you don't accidentally "splatter" your teammates with reflecting tags.

LCD SCREEN

VISUAL CONFIRMATION SYMBOLS



Flashes when you are tagged by another player.



Flashes when you tag another player.



Flashes when your TAGGER is aimed directly at another player.



Displays when there is an opposing player nearby.

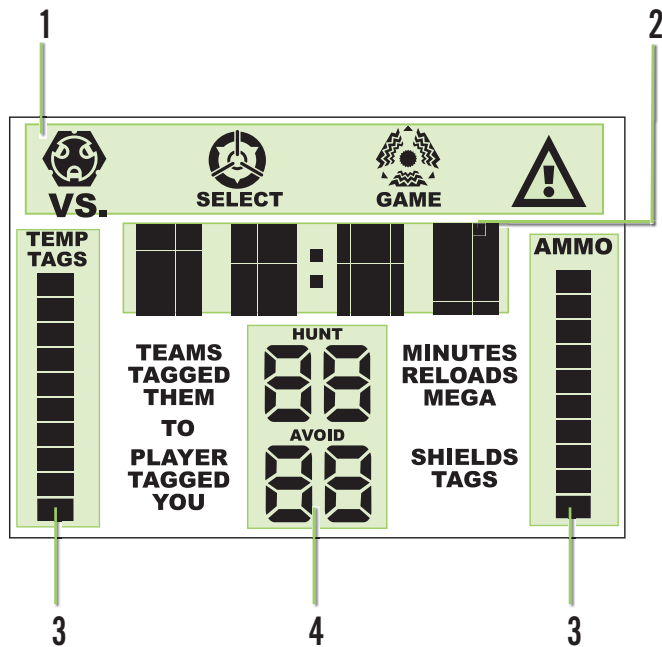

1. Alert Icons (Tagged, Locked-On, Scored, Danger)
2. Alpha-Numeric Display (Instruction, Game Type, Time, Warnings)
3. Multipurpose Bar Graphs (Ammo, Tags)
4. Reconfigurable Numeric Display (Team, Player, Ammo, Shields, Tags)

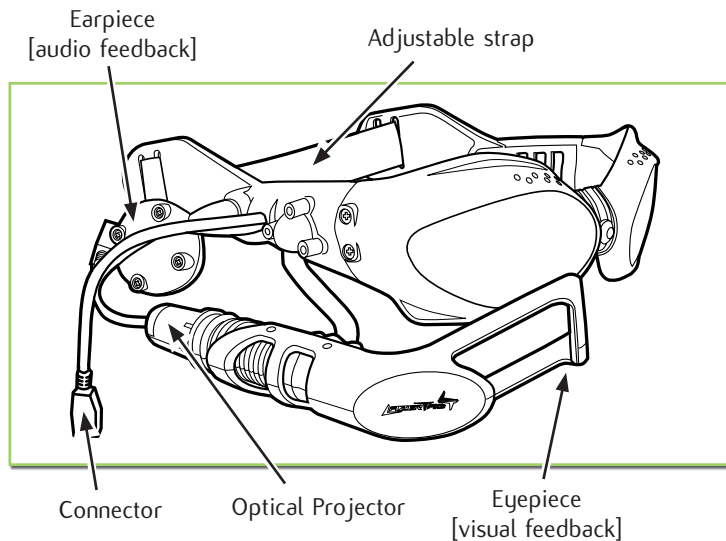

HUD (HEADS UP DISPLAY)



VISUAL CONFIRMATION SYMBOLS:

- Red  Flashes when you are tagged by another player.
- Yellow  Flashes when you tag another player.
- Green  Flashes when your TAGGER is aimed directly at another player.

TO HOOK UP THE TAGGER TO THE HUD (HEADS UP DISPLAY) HEADSET SYSTEM

Plug this end of the Connector Cable into the HUD (HEADS UP DISPLAY) Cable Port.

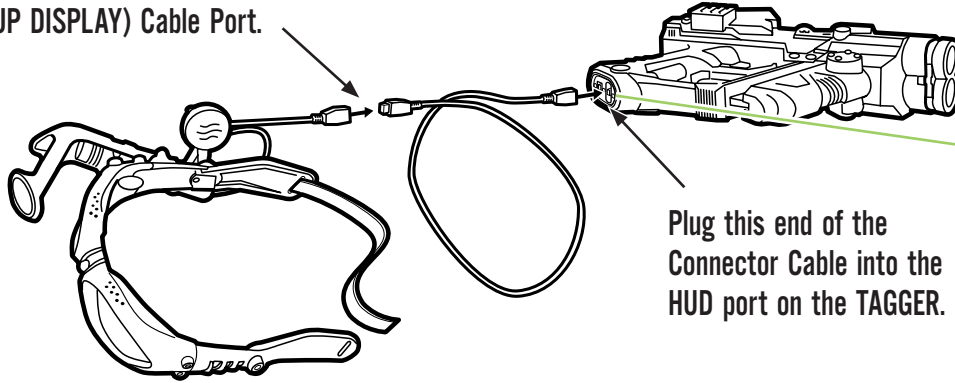

Plug this end of the Connector Cable into the HUD port on the TAGGER.

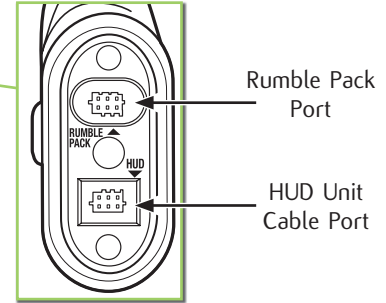

STICKERS

Several stickers have been included for you to decorate your TAGGER. Please apply the stickers anywhere you like on your TAGGER with the exception of the: LCD screen, IFF Beacon/ Receiver Dome and the Launching and Receiving Tubes.

NOTE: Stickers are a one-time application.

PLEASE NOTE: Do not cover HUD lenses with stickers.

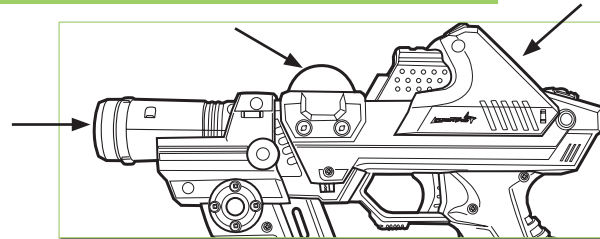

Do not place stickers where arrows are indicating.

TO WEAR THE HUD (HEADS UP DISPLAY) HEADSET SYSTEM

1. Wake up the TAGGER by pressing the TRIGGER.
2. Put the HUD (HEADS UP DISPLAY) HEADSET on over your head, similar to putting on a pair of sunglasses. Take the right side of the headband, and stretch it across the back of you head, and loop it through the holder on the left side. Pull the headband tight to the back of your head and fasten by pressing down firmly. Adjust the strap on the back of your head so that the headset is firmly in place. Make sure the HUD (HEADS UP DISPLAY) OPTICAL PROJECTOR is on your right side, and that you can see clearly through the lenses.
3. Move the OPTICAL PROJECTOR to position the EYEPIECE so that you can clearly see your Visual Confirmation Symbols.
4. Adjust the brightness of the Visual Confirmation Symbols using the DISPLAY BRIGHTNESS SLIDE SWITCH.

NOTE: The TAGGER will function properly without the HUD (HEADS UP DISPLAY) attached.

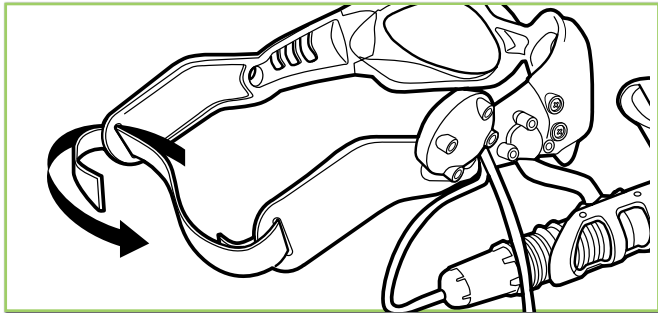

LAZER TAG® CODE OF CONDUCT

LAZER TAG Players follow a strict code of conduct when playing LAZER TAG. The following is the Official LAZER TAG Code Of Conduct that should be strictly adhered to in every game of LAZER TAG.

Rule 1: LAZER TAG is a non-contact sport

This means no physical contact between you and other players – EVER!

Rule 2: No covering the Receiver Dome

This means do not use anything to cover up the Receiver Dome thereby preventing you from receiving tags. If you want to avoid being tagged, you must use your defensive shields or take cover behind something.

Rule 3: Equipment Failure means Disqualification

In the event that your TAGGER fails to work, you are disqualified and must wait until the end of the game to join the next one. Please check your TAGGER and HUD (HEADS UP DISPLAY) carefully before entering a game to ensure that it is working properly.

Rule 4: LAZER TAG is a Game

Players must remember that LAZER TAG is only a game. It is designed purely for recreational use and for fun. Not having fun is against the code.

Rule 5: LAZER TAG is a Team Sport

Although LAZER TAG is a highly competitive sport, in many of the games you must consider the success of the team first. Players will win and lose as teams, not individuals. There's no "I" in "TEAM!"

LAZER TAG[®] GAME FEATURES

Common to all LAZER TAG games are:

- **Lock-On** – Your  on your LCD screen will blink to indicate that there is another player in your sight. The green light icon in the HUD (HEADS UP DISPLAY) will also flash. Tag your opponent when you are locked-on.
- **IFF** – (Identification, Friend or Foe) You will hear the sounds “bee-bee-beep, bee-bee-beep” if the player you are locked-on to is someone you are supposed to tag (your enemy), or “poonk-poonk-poonk” if they are someone you are not supposed to tag (your teammate).
- **Proximity** – You will hear “Danger” if your enemy is nearby.
- **Reloads** – You must reload after launching 10 tags. You can reload sooner without losing the tags you haven't launched. You will hear a mechanical click.
- **Shields** – You can raise defensive shields, lasting up to 10 seconds each by pressing the SHIELD BUTTON once to raise the shield and again to lower the shield. When your shields

are raised, your opponents cannot tag you, you cannot launch any tags, and no other player can get a lock-on to you or any IFF info about you. When shields are raised, both bar graphs will be shown as “full” until you have less than 10 seconds of shield time left in the game. Below 10 seconds, these bars will decrease to warn you that you should conserve your remaining shield time. There is a mandatory 2-second cool down period between lowering and raising your shield again.

- **Mega-Tags** – You can create a Mega-Tag by adding up to 3 additional tag points to a tag that you are about to launch. You add tag points by holding FUNCTION and pressing TRIGGER once for each additional tag you want to add to the basic tag. Once you have added the extra tags, release the FUNCTION button. The next time you pull the TRIGGER you will be launching that Mega-Tag. A Mega-Tag will cause your TAGGER to “overheat” for 2 seconds per extra tag added. During that time you can't launch any more tags or raise your shields, but you can still be tagged by other players.
- **T-Minus** – The counter that counts down to start a game.
- **Medic Mode** – Allows you to transfer some of your remaining tags to a teammate, either to help them if they are nearly tagged out, or to build them up so they can withstand a large number of tags without fear of being tagged out. This is an advanced feature, and is described in detail in the MEDIC MODE section.

- **Team Tags** – The Host can choose whether tags from your own teammates will or will not affect you. Make sure you ask whether the TAG MASTER has selected Team Tags or not! Tagging members of your own team counts against your ranking at the end of the game and in some games can hurt your team's ranking as well.

- **Alternate Displays** – You can select which game data you want to display by pressing DISPLAY at any time during the game to switch between them. The display modes are:

- **Primary** – Displays the game timer, number of Mega-Tags, and seconds worth of shields you have left in the game.
- **Secondary** – Displays the game timer, number of Reloads you have left, and the number of Tags you have left until you are tagged out.
- **Last Tagger (Hosted games only)** – Displays “TAGR” and the ID of the last player to tag you.
- **ID (Hosted games only)** – Displays “ID:” and your Team and Player ID in this game.
- **Zone Time (Zone games only)** – Displays “ZONE” and the number of minutes and seconds of Zone Time you have accumulated.
- **Hunt / Avoid (Hunt the Prey games only)** – Displays “HUNT” and which team you are supposed to be hunting and which team you are supposed to be avoiding.
- **Hide / Seek (Hide And Seek games only)** – Displays “HIDE” or “SEEK” to remind you which mode you are in.

These displays may become temporarily overridden in the event

that you need to be alerted to special conditions – such as being Overheated or Neutralized, having raised your shields, or if a direction swap has just taken place.

- **Team and Player Ranking** – At the end of all games except Classic LAZER TAG, the performance of each team and individual player is ranked against all others in the game.

- **Head-To-Head Scoring** – All games except Classic LAZER TAG support head-to-head score comparisons after the Rankings are done. Each player can see how many times they tagged each of the other players in the game, and how many times they were tagged by each of the other players.

- **Mute** – The SFX may be turned on or off by pressing and holding the 2ndF button for 2 seconds once the game is going – there will be one “beep” to let you know when the button has been recognized, and then there will be no more SFX until the game ends or you press and hold 2ndF for another 2 seconds.

- **Contrast/Brightness** – You can adjust the brightness (darkness) of the LCD screen by holding 2ndF and pressing DISPLAY. Remember not to hold 2ndF for too long, or the TAGGER will think you are muting the SFX.

- **Sleep** – You can quit a game at any time by holding 2ndF and pressing CANCEL. The TAGGER will go to sleep and the game will be lost. Do not do this in Hosted games, because it means your score data is lost and that could affect other player's scores (see the section on Debriefing).

MEDIC MODE

Medic Mode is used to give assistance to, or receive assistance from, other players on your team. It can be used to assist a player who is in danger of being tagged out, or to build-up one of your team's players into a "bulldog" by giving them the ability to take extra tags. Bulldogs can charge into the middle of the opposing team to break-up their defensive formations or scout for their king, without having to worry so much about being tagged out.

You may assist each of your teammates only once per game.

Medic Mode is a close-proximity operation requiring the team members to remain very close to one another (within approximately 10 feet) until the Medic Mode operation is completed.

Medic Mode is always initiated by a Requesting Player, who does so by holding FUNCTION while pressing and releasing the SHIELD BUTTON, then releasing FUNCTION. The Requesting Player's LCD screen will display "HELP" for approximately 3 seconds and will automatically call out to all other teammates within a 10-20 ft. radius for help. The Requesting Player then waits for assistance from a willing teammate. The Requesting Player will know when assistance is received by hearing a sound effect, and their LCD screen will display "RCVD TAGS." The Requesting Player can also

select the Secondary Alternate Data Display to watch the Tags counter increase as tags are added.

When a nearby teammate requests assistance, all the TAGGER units of players who have not yet assisted the Requesting Player will display "SEND" along with "00" shown as the amount of assistance to send, and the Requesting Player's ID. If the team member does not wish to send assistance at this time, he may simply press the CANCEL button to dismiss the request, or OK to send zero assistance, which is the same as dismissing the request (either way, they can still assist this player later in the game if needed).

To provide assistance to the Requesting Player, the Assisting Player selects the number of tags to send by using the INC. and DEC. buttons. To help determine the number of tags to send, the DISPLAY button switches between the "SEND" screen showing the number of tags to send, and a "HAVE" screen showing the remaining tags the Assisting Player can take until being tagged out. Pressing OK from within the "SEND" screen sends the selected number of tags to the Requesting Player.

Tags sent from the Assisting Player are subtracted from the number of tags the Assisting Player can take until being tagged out. Tags received from the Assisting Player are added to the number of tags the Requesting Player can take before being tagged out. The players will hear a sound effect to confirm

that the Medic Mode operation has concluded successfully. The actual transfer is performed via the Receiver Dome.

Medic Mode has many benefits, but it also has important limitations. Please note the following:

- The Assisting Player must respond within 20 seconds of receiving the request for assistance.
- The Assisting Player can never send his/her last tag, and can never send more than 40 tags at one time.
- The tags sent are lost to the Assisting Player, even if the Requesting Player does not receive them.
- Players cannot initiate or respond to a request for assistance if they have been tagged out, neutralized, overheated, or have their shields raised.
- If an Assisting Player is tagged out after pressing OK, and before the assistance has been received by the Requesting Player, the Medic Mode transfer will fail and no transfer of tags will take place. Make sure you are in a safe place before starting a Medic Mode operation!
- The Requesting Player is still limited to having only 99 tags at any one time so don't request or send any more – they will just be lost.
- Players can still be tagged and launch tags while requesting or assisting in Medic Mode.

NOTE: If multiple Assisting Players wish to assist the same Requesting Player, they must be within 10 feet of the Requesting Player, and they should take turns sending their assistance (this may require the Requesting Player to make multiple requests). This will minimize the possibility of confusing the Requesting Player's TAGGER, which could result in lost assistance.

PROGRAMMABLE GAMES

Be the TAG MASTER!

Think you've got what it takes to be the TAG MASTER? Prove it by being the winner in your first game of LAZER TAG! Earn this title and you will have the privileges of being the host for every game!

All of the games except Classic LAZER TAG require the game options to be programmed by the TAG MASTER. Any player can be the TAG MASTER, but there is only one per game. Once the TAG MASTER has programmed all of the game options into his/her TAGGER, it will automatically transfer the options to all of the other TAGGER units as they join the game (these players are called Joiners). The TAG MASTER will have exactly the same powers and abilities as all of the other Joiner Players in the game.

All programmed games run for a given time (programmed by the TAG MASTER). Once the game ends, all players bring their TAGGER units together with the TAG MASTER TAGGER, which automatically "debriefs" them. The TAG MASTER TAGGER learns how well each player did in the game, and then automatically ranks all players and teams, so that each player can see how well they did as compared to the other teams and players in the game.

In all of the games except for Zone games (OWNZ, 2TOZ, and 3TOZ) the TAG MASTER plays using the TAG MASTER TAGGER. In Zone games, the TAG MASTER must program the game into one TAGGER, which becomes the ZONE TAGGER, and then use his/her own TAGGER to JOIN the game like any other player.

The Zone TAGGER should be set-up so that it is level, is not hidden from view, and can easily broadcast it's beacon to a large enough area that players may move around in it and still remain "In the Zone."

NOTE: When setting up to Host or Join a game, and during Debriefing, please make sure to hold all TAGGER units level and at similar heights. If possible, all players should stand in a circle and face each other during these processes.

TO HOST A GAME OF LAZER TAG®

1. Press the TRIGGER to wake up your TAGGER.
2. The TAGGER will make a power-up sound and then display the Main Menu which has four options:
 - LTAG – Play a basic Grab & Go game of Classic LAZER TAG.
 - JOIN – Join a game Hosted by another player.
 - HOST – Be the TAG MASTER and host a game for other players to join.
 - QUIT – Return to "sleep" mode.
3. Use the INC. and DEC. buttons to scroll to HOST and press OK.

You are now in the Host Menu where you will have the following 10 game options to choose from:

- CUST – customized game for individual players
- 2TMS – customized game for 2 teams
- 3TMS – customized game for 3 teams
- HDSK – Hide and Seek game for 2 teams
- HUNT – Hunt the Prey game for 3 teams
- 2KNG – Kings game for 2 teams
- 3KNG – Kings game for 3 teams
- OWNZ – Own the Zone game for individual players
- 2TOZ – Own the Zone game for 2 teams
- 3TOZ – Own the Zone game for 3 teams

"Individual players" means the players are not divided into teams, it's "every player for themselves." All Hosted games must have at least 2 players.

4. Use the INC. and DEC. buttons to scroll through these options to the game you want and press OK.
 - TT: Y or N – Team tags, yes or no. Decide whether tags from players on your team do (Y) or do not (N) count against you.
 - MM: Y or N – Medic Mode, yes or no. Decide whether players on a team can (Y) or cannot (N) assist their teammates by transferring some of their remaining tags to their teammates.
 - TIME: <##> - Time limit for the game, in minutes.



- **RELD: <##>** - Number of reloads available for each player. Each reload gives you 10 additional tags. This value can be anywhere from 0 to 99, or unlimited (“UL”).
- **MEGA: <##>** - Number of Mega-Tags available for each player. This value can be anywhere from 0 (no Mega-Tags allowed) to 99, or unlimited (“UL”), but can never be greater than the total number of tags.
- **SHLD: <##>** - Total seconds of shield time available for each player. This value can be anywhere from 0 (no shield time allowed) to 99 seconds.
- **TAGS: <##>** - Number of Tags each player can take until they are tagged out. This can be any number from 1 to 99.

5. Program the functions for the game using the INC. and DEC. buttons to increase or decrease the value or to switch between Y and N. You can also hold down the 2ndF button and press INC. or DEC. to increase or decrease the value by 10. If you want to select “UL”, it is located just below 00 and just above 99. Once you have adjusted each value to your desired amount, press OK to select that value and move on to the next option to be adjusted.

If you need to go back and change something, you can press CANCEL to back-up through the options until you get to the one that you want to change. All the other options that you have already set will remain programmed, so you can simply press OK to skip over them.

Once you have set the number of TAGS (the last option), the screen will display: “ADD” above two numbers, and will begin making a sound effect. This sound effect indicates that the TAG MASTER will start joining other players into the game. The top number is the total number of players who are now in the game, and the bottom number is a countdown timer for the game’s automatic start (it will start automatically if that counter reaches 00 and there are at least 2 players in the game). The TAG MASTER needs to wait until all players have successfully joined the game before starting the game. The TAG MASTER can delay the automatic start of the T-Minus countdown by pressing OK at any time to restart the 60-second timer.

6. The TAG MASTER can start the game by waiting for the lower countdown to reach 00, or at any time after at least 2 players are in the game by pressing 2ndF and OK. All Joiner TAGGER units must come close to the TAG MASTER TAGGER for several seconds during this period. The LCD screen will now show the T-Minus screen and the TAGGER will count down from T-30, T-29, T-28, etc. and beep each time to alert the players, until it reaches T-00 at which point the TAGGER will say “GOOD LUCK!” and the game begins! The TAG MASTER should remain in one place until all other players have begun the T-Minus countdowns on their own screens, at which time

the TAG MASTER is free to take up his/her initial position.

NOTE: If you are Hosting a Zone game (OWNZ, 2TOZ, 3TOZ) the TAG MASTER TAGGER will become the Zone, not a player TAGGER. When the T-Minus countdown screen has concluded and the TAGGER says “GOOD LUCK!” it will display “ZONE” on the LCD screen and the number of minutes and seconds remaining in the game.

NOTE: Once the TAG MASTER TAGGER begins the Joining process, the game is set and cannot be modified. To terminate the game before it has begun, all players must hold their 2ndF buttons and press CANCEL to put their TAGGER units to sleep.

TO JOIN A GAME OF LAZER TAG®:

NOTE: In order to join a game, the Joiner TAGGER must remain physically close to the TAG MASTER (within 10 feet) until your TAGGER starts the T-Minus countdown.

NOTE: It may take some time for each Joiner to enter the game, as the TAG MASTER registers players one at a time. Please join games one at a time otherwise the TAG MASTER TAGGER may get overloaded with information and it will take longer to begin a game.

1. Turn your TAGGER on by pressing the TRIGGER.

2. The TAGGER will make a power-up sound and then display the Main Menu which has four options:

- LTAG – Play a basic Grab & Go game of Classic LAZER TAG.
- JOIN – Join a game Hosted by another player.
- HOST – Be the TAG MASTER and host a game for other players to join.
- QUIT – Return to “sleep” mode.

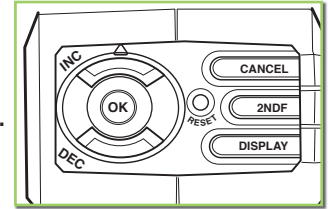

3. Use the INC. and DEC. buttons to “JOIN” and press OK. The LCD screen will display “WAIT” as it waits for instructions from the TAG MASTER, and will display a countdown to show how many seconds are left to join the game. If you were not able to join the game in the allotted time, your TAGGER declares a failure to join the game by playing a sound effect and displaying “NO GAME” in the Text Read-Out.

4. Upon communication with the TAG MASTER, the LCD screen will display the name of the game. For individual games the TAG MASTER will control all game set up and game start. Skip to Step 6 for individual games.

5. For games with teams, your LCD screen will also display a flashing “TEAM” icon, prompting you to select a team. Select your desired Team by pressing the INC. and DEC. buttons and then OK. If you do not care which team you join, select “-”

then press the OK button and the TAG MASTER will assign you to the team with the fewest players, in order to keep the teams even.

NOTE: The team you are assigned to may be different from the team you requested. The TAG MASTER will attempt to honor all team requests, but it cannot assign more than 8 players to any given team. Players should discuss who will be on which team, before game is set up by the TAG MASTER.

6. When the Joiner enters the game the LCD screen will display “IN!” as well as your Team and Player number.
7. Once all players have joined a team and game, the TAG MASTER will enter the T-Minus countdown screen. It is **VERY IMPORTANT** that you remain near the TAG MASTER until your own LCD begins displaying the T-Minus countdown. If you wander away from the TAG MASTER before your T-minus screen starts, your TAGGER will prompt you to “FIND HOST”. If you do not return to the vicinity of the TAG MASTER within 60 seconds, you will be dropped from the game and your LCD screen will show “FAIL”. You must then either re-join the game (receiving a new Team and Player ID) or sit out this game.
8. Once your screen starts the T-Minus countdown, you can safely go to your starting position. When the T-Minus

countdown reaches “T-00” the game will start automatically, and will run for the selected number of minutes.

END OF GAME DEBRIEFING AND SCORING

The game ends and the debriefing process begins when the game timer runs out. If you are tagged out before the game ends, your TAGGER will continuously display “WAIT FOR GAME OVER” alternating with the time left until the game ends.

When the game ends, your TAGGER will display “GAME OVER” and then constantly prompt you to “FIND HOST.” You now have 2 minutes to return your TAGGER to the TAG MASTER in order to be debriefed. You must then remain within 10 feet of the TAG MASTER until the Debriefing process is complete in order to receive your ranking. Because of the 2-minute time limit for returning to the TAG MASTER, all players should reach an agreement before the game starts about where they will meet for the debriefing, so that there is no confusion.

During the debriefing process, the TAG MASTER’s screen will prompt the TAG MASTER to “FIND” each of the other players in turn, waiting approximately 3 seconds to contact each of the Player TAGGER units. If that Player TAGGER is present, the TAG MASTER will automatically download all the score information from that Player TAGGER and will use it to calculate how that

player and their team did in the game. If a player is slow getting to the Debriefing, the TAG MASTER can temporarily skip over him by pressing OK to move on to the next Player TAGGER to be debriefed. The TAG MASTER will eventually come back to the skipped TAGGER automatically and debrief it. If a player has quit the game, reset their TAGGER or put their TAGGER to sleep (so that their data cannot be gathered), the TAG MASTER can press CANCEL to drop that player from the game. This should only be done as a last resort, because all tags which that player landed on the other players will count against the other players, but those same other players will not get credit for any tags they landed on the missing player.

When the Debriefing is complete, the TAG MASTER will upload the rankings for each player and team to all the TAGGER units automatically. All player LCD screens will display three different options (press DISPLAY to switch between them):

- RANK – How you and your team placed in the game
- ID – What your player and team numbers are
- VS – Shows a head-to-head comparison of how you did against each of the other players in the game. Use the INC. and DEC. buttons to select which opposing player you want to see data for. Each other player in the game is shown as “TxPy” (Team X, Player Y on that team), or just “P: xx” (Player XX) if there were

no teams. Below this are two numbers which show how many times you TAGGED THEM and how many times they TAGGED YOU. If “??” is displayed in the TAGGED THEM section, press OK to request this data from the other player’s TAGGER.

In addition to these three screens, the Host has an additional screen in which he/she can call up the RANK screen for any player in the game.

ENDING GAMES EARLY

All Hosted games will normally end at the programmed time limit. However, the TAG MASTER can declare an early end to the game by holding 2ndF and pressing OK. The TAG MASTER will then immediately end its own game and begin debriefing any players nearby. All players must then be called to come to the TAG MASTER within 2 minutes, or the TAG MASTER will count them out of the game and they will receive no score – so make sure everybody knows that you are calling an early end to the game before you actually call it.

Any player who was not yet tagged out at the time the game was called early will be considered to have not been tagged out in the game. In Zone games, such players receive full credit as if they had spent the entire rest of the originally-programmed game time in the zone.

11 PRE-PROGRAMMED LAZER TAG® GAMES

1. CLASSIC LAZER TAG (LTAG)

The object of this game is to be the last player **not** tagged out. It is an aggressive, go-get-em type of game.

In the Classic LAZER TAG game, all other players are your opponents. [TAG09]

Of all the games you can choose to play, Classic LAZER TAG is the only game that has no hosting or joining at the beginning of the game, no debriefing, ranking, or head-to-head comparisons at the end of the game, and has unlimited time to complete the game.

Also, players may enter or leave the game at any time as they wish.

Preset game features are:

- No Hosting, game starts immediately at T-10
- No Teams or Player ID's
- Any number of players may play
- 15 seconds of Shield time allowed
- Unlimited Reloads
- 10 Mega-Tags
- Players are tagged out after taking 10 Tags
- No score ranking – last player **NOT** tagged out wins.
- After being tagged out, a player's elapsed time in the game (from the start of the game to the time at which the player is tagged out) is displayed on your LCD screen.

2. CUSTOM LAZER TAG (CUST)

The object of this game is to be the last player not tagged out, while scoring as many tags against your opponents as possible.

In the Custom LAZER TAG game, all other players are your opponents. [TAG01]

This variation of Classic LAZER TAG allows all game options to be programmable.

Game features are:

- Fully hosted, (requires hosting/joining) and supports post-game debriefing
- 2-24 players may be in the game, players have individual ID's
- No Teams, All players are opponents of each other
- Time – 1-99 minutes, (default =10 min)
- Reloads – 0-99 or Unlimited (default =Unlimited)
- Mega-Tags – 0-99 or Unlimited (default =10)
- Shields – 0-99 seconds (default =15)
- Tags – 1-99 (default =10)
- Ranking is individual only
 - Individual ranks are based on receiving 2 points per tag landed on other players, and losing 1 point for every time you're tagged by another player.

3. 2-TEAM CUSTOMIZED LAZER TAG (2TMS) AND

4. 3-TEAM CUSTOMIZED LAZER TAG (3TMS)

The object of these games is to have the most number of your team's players remain in the game, while scoring as many tags as possible on opposing players. [TAG80]

In these games, some of the other players are on the same team as you, while others are on one or two opposing teams. It is important that you work with your teammates in order to achieve a high team ranking. Do this by helping to protect any of your teammates who are in danger of being tagged out, and working with your teammates to tag the opposing players out as quickly as possible.

Game features are:

- Fully hosted, (requires hosting/joining) and supports post-game debriefing
- 2 or 3 teams of up to 8 players per team
- Team Tags (selectable) – Yes (Y) or No (N) (default =Y)
- Medic Mode (selectable) – Yes (Y) or No (N) (default =Y)
- Time – 1-99 minutes, (default =15 min)
- Reloads – 0-99 or Unlimited (default =Unlimited)
- Mega-Tags – 0-99 or Unlimited (default =10)
- Shields – 0-99 seconds (default =15)
- Tags – 1-99 (default =20)
- Ranking is individual and team
 - Individual ranks are based on receiving 2 points per tag landed on players from other teams, and losing 1 point for every time you're tagged by a player from another team. Tagging your own teammate (Team Tags) costs you 2 points. Being tagged by your own teammates does not hurt your score.
 - Team ranks are based on which team has the most players not tagged out when the game ends (this gives an advantage to larger teams, so less-skilled players can be grouped together on a larger team to even things out). In the event of a tie, the TAG MASTER will attempt to break the tie based on the

individual scores of the players on each team who did not get tagged out – this rewards the team with the more aggressive players that land more tags. Just hiding or trying to not get tagged may cost your team valuable points that could affect your team's ranking.

5. HIDE AND SEEK (HDSK)

The object of this game is to score as many tags as possible on the other team while seeking them, and avoid taking tags while hiding from them. [TAG06]

Players are divided into two teams. At any given time, one team is seeking while the other team is hiding. The teams switch between seeking and hiding every 60 seconds. When the switch happens, each TAGGER will then display “HIDE” or “SEEK” for 5 seconds to tell the player which mode they are in. When a seeking player tags a hiding player it scores points for the seeking player and his/her team. If a hiding player tags a seeking player, it helps the seeking player by giving him/her one more tag he/she can take until he/she is tagged out.

Game features are:

- Fully hosted, (requires hosting/joining) and supports post-game debriefing
- 2 teams of up to 8 players per team
- Team Tags (selectable) – Yes (Y) or No (N) (default =Y)
- Medic Mode (selectable) – Yes (Y) or No (N) (default =Y)
- Time – 2-98 minutes (minutes in multiples of 2), (default =10 min)

- Reloads – 0-99 or Unlimited (default =5)
- Mega-Tags – 0-99 or Unlimited (default =15)
- Shields – 0-99 seconds (default =30)
- Tags – 1-99 (default =25)
- Ranking is individual and team
 - Individual ranks are based on receiving 2 points per tag landed on players from other teams, and losing 1 point for every time you're tagged by a player from another team. Tagging your own teammate (Team Tags) costs you 2 points. Being tagged by your own teammates does not hurt your score.
 - Team ranks are based on the total scores of all players on the team. This gives a slight advantage to larger teams. In the event of a tie, the TAG MASTER will attempt to break the tie based on the scores of only those players who were not tagged out at the end of the game.

6. HUNT THE PREY (HUNT)

The object of this game is to score as many tags as possible on the other team while seeking them, and avoid taking as many tags as possible while hiding from them. [TAG22]

This game is like Hide and Seek, but with the added complexity that players are divided into three teams. At any given time, your team will be hunting one team while hiding from the other team. Every 60 seconds the hunting direction switches so that you must now hide from the team you were just hunting and hunt the team you were just hiding from. All TAGGER units will be alerted just before the switch with a sound effect, and then for 5 seconds after the switch the TAGGER units will display "SWAP" and the new teams to "HUNT" and "AVOID."

Game features are:

- Fully hosted (requires hosting/joining) and supports post-game debriefing
- 3 Teams. Up to 8 players on each team
- Team Tags (selectable) – Yes (Y) or No (N) (default = Y)
- Medic Mode (selectable) – Yes (Y) or No (N) (default = Y)
- Time – 2 - 98 minutes (minutes in multiples of 2) (default = 10 min)
- Reloads – 0 - 99 or Unlimited (default = 5)
- Mega-Tags – 0 - 99 or Unlimited (default = 15)
- Shields – 0 - 99 seconds (default = 30)
- Tags – 1 - 99 (default = 25)
- Ranking is individual and team
 - Individual ranks are based on receiving 2 points per tag landed on hiding players while you are hunting them, and losing 1 point for every time you're tagged by a hunting player while you are hiding from them. Tagging your own teammate (Team Tags) counts as 2 points against you. Being tagged by your own teammates does not hurt your score.
 - Team ranks are based on the total scores of all players on the team. This gives a slight advantage to larger teams. In the event of a tie, the TAG MASTER will attempt to break the tie based on the scores of only those players who were not tagged out at the end of the game.

7. 2-KINGS (2KNG) AND

8. 3-KINGS (3KNG)

The object of these games is to tag out the opposing team's King while protecting your own King.

The Kings on any of the teams are not known to the other teams, the only clue is that the King's TAGGER will not send out an IFF signal. This prevents enemy players from sniffing for his IFF signal, but also makes it easier for them to determine that he is in fact the King once they do find him. These games may require individual players to sacrifice their own individual ranking for the greater good of the team, this is the nature of the game...protect your King even if it means being tagged out. [TAG61]

The TAG MASTER is always the King of Team 1, and the first player to join each of the other teams is the King of that team. The Kings are fully capable of tagging other players (including other Kings) and defending themselves by raising shields. The Kings cannot request or receive Medic Mode assistance.

Game features are:

- Fully hosted (requires hosting/joining) and supports post-game debriefing
- 2 or 3 Teams. Up to 8 players on each team
- Team Tags (selectable) – Yes (Y) or No (N) (default = Y)
- Medic Mode (selectable) - Yes (Y) or No (N) (default = Y)
- Time – 1 - 99 minutes (default = 15 min for 2-KINGS, and 30 min for 3-KINGS)
- Reloads – 0 - 99 or Unlimited (default = 20)
- Mega-Tags – 0 - 99 or Unlimited (default = 00)
- Shields – 0 - 99 seconds (default = 30)

- Tags – 1 - 99 (default = 15)
- Ranking is individual and team
 - Individual ranks are based on the number of tags you have landed on the other Kings. Tagging your own King counts as 4 points against you. If your King is tagged out before the game ends, you will rank last.
 - Team ranks are based on how long each King lasted before being tagged out. If more than one king lasts until the end of the game, the team whose King took the fewest tags wins.

ZONE GAMES

In Zone games the TAGGER MASTER TAGGER becomes the Zone TAGGER. The Zone TAGGER does not participate in the game as a player although it still performs all set-up and programming functions and performs the debriefing at the end of the game.

The Zone TAGGER creates the Zone by generating a 360° infrared light field using its Receiver Dome. The Zone TAGGER should always be stationary during a game and positioned on a stable surface with the Receiver Dome pointing straight up and level with the ground. The Zone TAGGER should be located in a place so that the Zone can fill a large area, without obstructions that may create dead spots within the Zone.

All TAGGER units in the game sense the Zone using their Receiver Domes. TAGGER units accumulate Zone Time whenever they can sense the Zone. Multiple players may be in the Zone at the same time.

A player may remain in the Zone as long as he/she is not “Neutralized.” When a player takes a Tag from any other player, whether he/she is in the Zone or not, the tagged

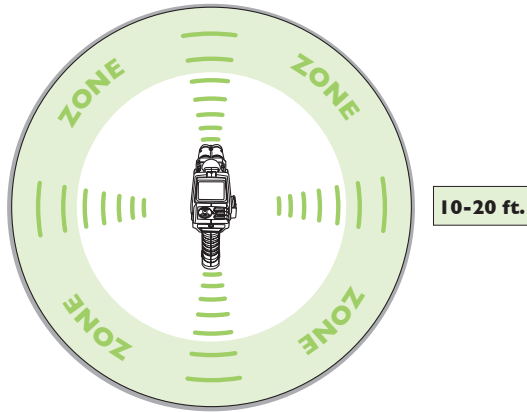

player becomes “Neutralized” for 15 seconds. The neutralized TAGGER will display “NEUT” with a fifteen-second countdown. A neutralized player cannot tag other players, be tagged by other players, raise shields or add Mega-Tag power. A neutralized player must leave the Zone within 5 seconds of being tagged and remain completely out of the Zone while neutralized. If a player stays in the Zone or returns to the Zone while neutralized, the Zone will become Hostile to that player. A Hostile Zone will cause a player to take multiple tags from the Zone at a pace fast enough to be completely tagged out of the game within just a few seconds.

NOTE: You will still accumulate Zone time if you are in the Zone with your shields raised. You will NOT accumulate Zone time however, if you are neutralized with your shields raised and are in the Zone.

9. OWN THE ZONE (OWNZ)

The object of the game is to accumulate as much Zone Time as possible.

Own the Zone is a strategic individual game where all players are opponents. Players should focus on getting into and staying in the Zone as long as possible without getting tagged, rather than attacking the opponents. The player with the most Zone Time wins the game. It should be noted that multiple players can be in the Zone at the same time, as long as they can avoid getting tagged.

Game features are:

- Fully hosted (requires hosting/joining) and supports post-game debriefing
- 2-24 players
- No Teams. All players are opponents
- Time – 1 - 99 minutes, (default = 10 min)
- Reloads – 0 - 99 or Unlimited (default = 15)
- Mega-Tags – 0 - 99 or Unlimited, (default = 0)
- Shields – 0 - 99 seconds (default = 45)
- Tags – 1 - 99 (default = 10)

- Ranking is individual only
 - Individual ranks are based only on the player's accumulated Zone Time.

10. 2-TEAMS OWN THE ZONE (2TOZ) AND

11. 3-TEAMS OWN THE ZONE (3TOZ)

The object of the game is to accumulate as much collective Zone Time as possible for the whole team.

These two games are played in the same way as the Individual game of Own the Zone except that the players are divided into teams.

A good team strategy, once a zone is controlled, is to have one player designated as the "Zone Keeper". This player tries to stay in the zone at all times collecting as much Zone time as possible. The team should also position one or two "defenders" inside the zone ready to defend it against incoming hostile players. Finally, two or three "guards" could stay outside the Zone, preventing hostile players from getting close enough to attack the Zone and their teammates inside the Zone.

These guards should also attempt to control a safe area so that teammates that are tagged and neutralized (and that must leave the Zone) will have a safe place to go while de-neutralizing. When the Zone Keeper or a defender gets tagged, a guard will need to move into the zone to take his place while the tagged player waits to be de-neutralized. Fluidity, teamwork and coordination are the winning strategies in these games

as players on a team move in and out of the Zone, protecting the Zone, protecting each other and tagging all opponents who attempt to overtake the Zone.

Game features are:

- Fully hosted, (requires hosting/joining) and supports post-game debriefing
- 2 or 3 Teams. Up to 8 players on each team
- Team Tags – Yes (Y) or No (N) (default = Y)
- Time – 1 - 99 minutes, (default = 15 min for 2-TEAMS OWN THE ZONE, and 20 min for 3-TEAMS OWN THE ZONE)
- Reloads – 0 - 99 or Unlimited (default = 15)
- Mega-Tags – 0 - 99 or Unlimited, (default = 0)
- Shields – 0 - 99 seconds (default = 45)
- Tags – 1 - 99 (default = 10)
- Score ranking is Individual and Team
 - Individual Ranking is based on total Zone time each individual player accumulates.
 - Team Ranking is based on total Zone time of all players on a team as a group.

It is recommended that the Team Tags option be left to "N" (No) for team Zone games, as any "ricochets" or reflections inside the Zone (especially when playing indoors) may cause you to accidentally tag everyone on your entire team with a single badly aimed tag and force them all to leave the Zone. On the other hand, having Team Tags set to "Y" (Yes) makes for a very challenging game!

FCC STATEMENT

This equipment has been tested and found to comply with the limits for a Class B digital device, pursuant to part 15 of the FCC Rules. These limits are designed to provide reasonable protection against harmful interference in a residential installation. This equipment generates, uses and can radiate radio frequency energy, and, if not installed and used in accordance with the instructions, may cause harmful interference to radio communications. However, there is no guarantee that interference will not occur in a particular installation. If this equipment does cause harmful interference to radio or television reception, which can be determined by turning the equipment off and on, the user is encouraged to try to correct the interference by one or more of the following measures:

- Reorient or relocate the receiving antenna.
- Increase the separation between the equipment and the receiver.
- Consult the dealer or an experienced radio/TV technician for help.

Changes or modifications to this unit not expressly approved by the party responsible for compliance could void the user's authority to operate the equipment.

Lazer Tag is a trademark of Shoot the Moon Products and used with permission.

Energizer, Energizer MAX and other marks are trademarks of Eveready Battery Company, Inc.

®* and/or ™* & © 2004 Hasbro. All Rights Reserved.

® denotes Reg. U.S. Pat. & TM Office.

U.S. Patent No. 5,904,621

71970 P/N 6405480000



TIGER
ELECTRONICS

Where Technology Comes to Play!™*

CHECK OUT ONLINE GAMES AND TIPS AT
www.LAZERTAG.com