



Li'l Entertainer™

INSTRUCTIONS

Contents: 2 plastic screws, 2 plastic washers, keyboard, microphone, bench, console, songbook, label sheet, instructions and cross-sell.

SECTION 1

Play and sing along! Become a real entertainer!

Li'l Entertainer is an electronic keyboard with an adult sound. It has special features and sounds so kids feel like real entertainers! Kids play songs and create their own music with 25 adult-size keys in a removable keyboard for portable fun.

With four instrument sounds and four rhythms included in the keyboard, kids can try different combinations for unique and surprising sounds. A special chord-playing feature lets kids play up to three notes at once.

The special record/playback feature is easy to operate and lets little entertainers hear the musical creations they play!

Ten prerecorded songs are included in the keyboard. An easy to play songbook features popular songs that are color-coded to the keyboard. Kids can perform these songs or compose their own! Attach the microphone, and kids can sing along with the music!

Li'l Entertainer operates on 6 "C" alkaline batteries (not included) and is AC adaptable (AC adaptor not included).

SECTION 2

How to Insert Batteries in Li'l Entertainer

1. Turn bottom of keyboard face up. Press tab and lift battery cover (ILL. 1).

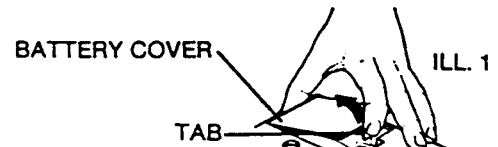

2. Insert 6 "C" alkaline batteries as illustrated (ILL. 2). Note engraving on keyboard bottom for reference on battery placement.

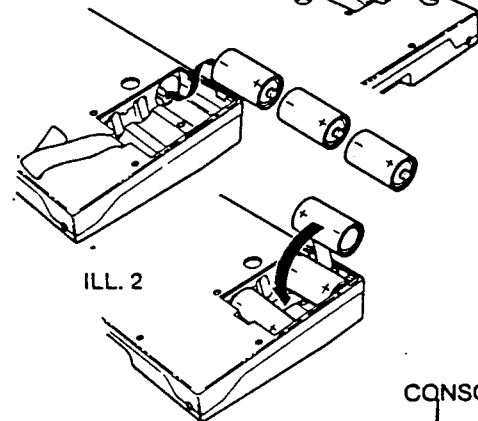

3. To replace battery cover, fit tabs into slots in battery compartment. Press tab to snap cover securely in place (ILL. 3)

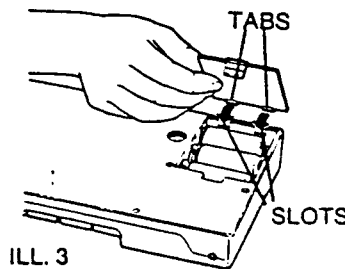

SECTION 3

Attaching Keyboard to Console

1. Stand console right side up. Insert two screws (included) up through holes on bottom of console (ILL. 4).

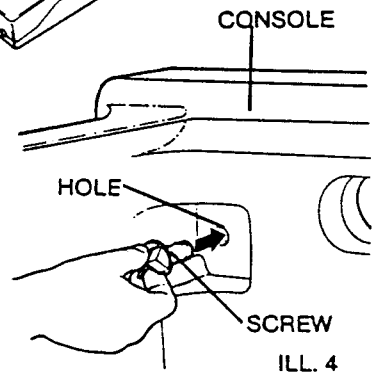

2. Place a washer (included) over each screw on top of console and snap in place (ILL. 5). Washers hold screws securely in place.

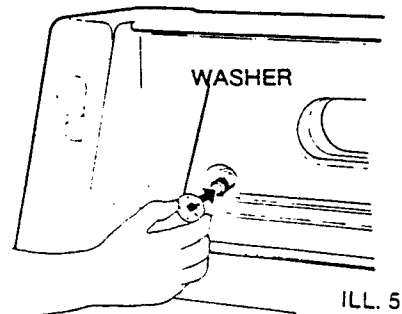

3. Place keyboard on console so that screws fit into holes in bottom of keyboard. Turn screws counterclockwise until keyboard is securely attached to console (ILL. 6).

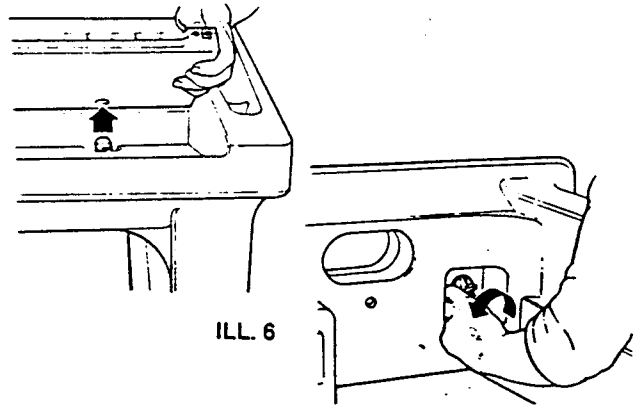

4. To detach keyboard from console, turn screws clockwise until they are no longer attached to keyboard. Lift keyboard off console (ILL. 7).

5. To play keyboard without console, place keyboard on any flat, stable surface such as a table.

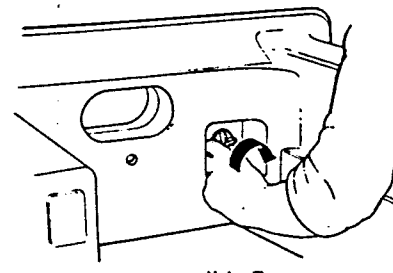

SECTION 4

Li'l Entertainer Keyboard Controls and Features

Power: Press Power button to turn keyboard ON.

Light: When glowing, light indicates Li'l Entertainer is on.

Function: Slide Function switch to select one of four modes.

Play: To play notes on the keyboard

Auto: To hear prerecorded songs included in keyboard

Playback: To hear songs you recorded on keyboard

Record: To record your own songs

Rhythm: Slide Rhythm switch from off position to choose one of four different rhythms: rock, swing, waltz or 16 beat.

Instruments: Slide Instruments switch to choose one of four different instrument sounds: piano, flute, organ or harpsichord.

Tempo: Press left button to speed up tempo. Press right button to slow down tempo. Hold for approximately half a second.

Volume: Slide Volume switch left to make music softer; right to make music louder.

Keys: Press the adult-size keys to play notes and chords or select prerecorded songs. In Play mode, press white and black keys to play songs from the songbook or create your own music. In Auto mode, press numbered black keys to hear ten prerecorded songs.

Headphone Jack: Use headphones (not included) to disconnect speaker for private listening. Insert headphone plug into jack to connect headphones to keyboard. Plug size: 3.5mm.

Microphone Jack: Insert microphone plug (included) into jack to sing along with music.

AC Adaptor Jack: Insert AC adaptor (not included) into jack to play Li'l Entertainer on electrical power instead of batteries.

IMPORTANT: Use a standard, high quality adaptor with positive (+) outside metal sleeve. Do not use a negative (-) outside sleeve—keyboard will not operate.

Note: If humming noise occurs when using AC adaptor, remove adaptor plug from wall socket, turn plug 180 degrees, and reinsert plug in socket.

Current Rating: 300 ma, Input 110V AC, Output 9VDC. Plug Size: 5.5mm Dia. x 12.5mm length.

Note: Li'l Entertainer has no OFF button. Keyboard automatically shuts off after approximately 4 minutes of non-use to conserve battery life.

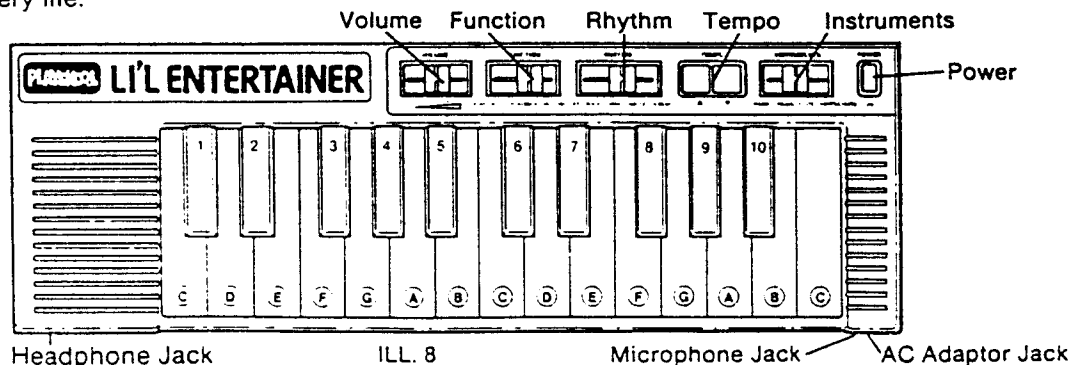

SECTION 5

To Apply Color-Coded Labels

To apply the color-coded labels to the keyboard, remove the circles from the label sheet and place them on the white keys as described on the label sheet. See page 2 of the songbook for proper placement of the colors.

SECTION 6

Create Your Own Music!

1. Press Power Button to start Li'l Entertainer.
2. Slide Function Switch to Play Mode.
3. Slide Rhythm Switch to one of four rhythms—rock, swing, waltz or 16 beat.
4. Slide Instrument Switch to one of four instrument sounds—piano, flute, organ or harpsichord.
5. Press left or right Tempo button to speed up or slow down tempo.
6. Slide Volume Switch right or left to adjust volume.
7. Have fun! Experiment with sounds, rhythms and tempos to create your own special music!

SECTION 7

To Play Songs from Songbook

The Li'l Entertainer songbook features fun songs for kids to play. The songbook is color-coded to the white keys for easy to play music. Simply press the key with the same color circle as marked for each note in the songbook.

SECTION 8

To Play Prerecorded Songs

1. Press Power button to start Li'l Entertainer.
2. Slide Function Switch to Auto Mode.
3. Choose song from chart below. Press black key marked with same number as song below.

KEY SONG TITLE

1	It's a Small World	6	Are You Sleeping? (Frere Jacques)
2	When the Saints Go Marching In	7	London Bridge
3	Happy Birthday	8	Jingle Bells
4	Twinkle, Twinkle Little Star	9	Mary Had a Little Lamb
5	Yankee Doodle	10	Old McDonald

Example: To hear Yankee Doodle, press the black key marked "5".

4. Encore! To play another prerecorded song, press another black key after first song is finished.
5. Keys will not play when keyboard is in Auto Mode. While song is playing, you can pretend to play keyboard—give a concert, or sing and dance along!
6. Change the songs! Slide Instrument Switch and Rhythm Switch to hear the songs with different instrument sounds and rhythms. Press Tempo Buttons to speed up or slow down the songs.
7. To stop song while it is playing, slide Function Switch to Play Mode. To play another prerecorded song, return Function Switch to Auto Mode, then press black key to choose song.

SECTION 9

Record/Playback Function

1. To record song, slide Function switch to Record mode. Rhythm will play.
Note: Rhythm will play even when Rhythm switch is off. To change rhythm, slide Function switch to Play or Auto modes, and select rhythm. Return Function switch to Record mode to begin recording again.
If unit shuts off or goes into Record mode, the music previously recorded will be erased. If the Function switch is moved from Record to either Play, Auto or Playback mode, the music will remain in the memory as long as the machine is on.
2. Play the song. Make sure you play "in time" with rhythm, otherwise recording may sound distorted.
Note: Li'l Entertainer can record up to 45 notes in memory. No more notes will be recorded after memory is full.
3. To hear recorded song, slide Function switch to Playback mode. Press any key to hear recorded song.
Note: Tempo can be adjusted while in Playback mode. Rhythm can be shut off but cannot be changed.
4. Hear a band! Change instrument sounds while in Record or Playback mode to hear song played by different instruments.

SECTION 10

Attaching and Using Microphone

Li'l Entertainer comes with a microphone so you can sing along with the music! Attach microphone to keyboard by inserting microphone plug into microphone jack (ILL. 9).

Play and sing along at the same time! For a free-standing microphone, place base of microphone into hole in storage area of console (ILL. 10).

Store microphone in storage area when not in use.

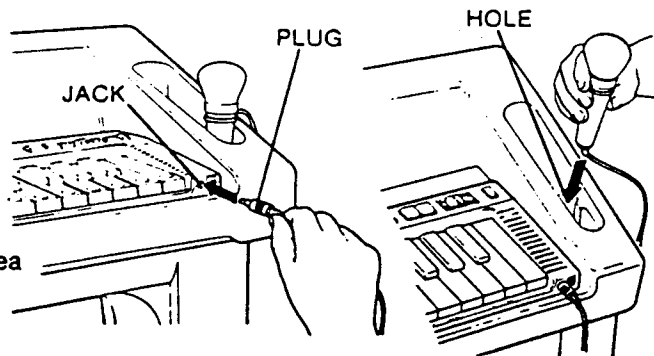

ILL. 9

ILL. 10

SECTION 11

IMPORTANT:

Play with and store Li'l Entertainer in temperatures below 110° F.

Do not leave Li'l Entertainer in a closed car or direct sunlight.

This equipment generates and uses radio frequency energy and if not used properly, that is, in strict accordance with the manufacturer's instructions, may cause interference to radio and television reception. It has been type tested and found to comply with the limits for a Class B computing device in accordance with the specifications in Subpart J of Part 15 of FCC Rules, which are designated to provide reasonable protection against such interference in a residential installation. However, there is no guarantee that interference will not occur in a particular installation. If this equipment does cause interference to radio or television reception, which can be determined by turning the equipment off and on, the user is encouraged to try to correct the interference by one or more of the following measures:

- Reorient the receiving antenna
- Relocate Li'l Entertainer with respect to the receiver
- Move Li'l Entertainer away from the receiver

If interference occurs when you use the AC adaptor, rotate the plug 180°, or try another outlet.

If necessary, the user should consult the dealer or an experienced radio/television technician for additional suggestions. The user may find the following booklet, prepared by the Federal Communications Commission, helpful:

"How to Identify and Resolve Radio-TV Interference Problems."

This booklet is available from the U.S. Government Printing Office, Washington, DC 20402, Stock NO. 004-000-00345-4.

LIMITED WARRANTY ON LI'L ENTERTAINER™ UNIT

Playskool warrants that your Li'l Entertainer unit is free from defects in material or workmanship for a period of 90 days from the date of purchase or receipt as a gift.

To Obtain Warranty Service

Please call our toll free hotline number

1-800-237-0063

and ask for Consumer Service so that we can provide you with instructions for obtaining service on your Li'l Entertainer.

Postage and Handling

If the unit is returned to us for warranty service, you must pay the postage for mailing it to us. We will pay the cost of returning the repaired or replaced unit to you.

PLEASE DO NOT RETURN YOUR UNIT TO THE RETAILER

DO NOT RETURN THE UNIT TO ANY ADDRESS WITHOUT AUTHORIZATION FROM PLAYSKOOL.

The warranty does not cover:

Defects caused by misuse, abuse, accidental damage, repairs made by others or failure to follow instructions.

This warranty gives you specific legal rights, and you may have other rights which vary from state to state.

Post Warranty Repair Policy

After the 90 day warranty period has expired, Playskool, Inc. shall, for a period of one (1) year from the date of purchase, either repair (not necessarily with a new product) or replace your Li'l Entertainer on the condition that you obtain authorization from the Playskool Consumer Service Department, shipping the unit prepaid to the address provided along with proof of purchase date and your check or money order in the amount of \$10.00. Playskool, Inc. shall not be obligated to perform this service if the Li'l Entertainer has been abused, misused, improperly serviced, or damaged due to accident.

GENERAL INSTRUCTIONS

Important: Before returning the Li'l Entertainer for repair, we recommend that you read the instructions carefully and test your product with fresh batteries.