

The
GAME
of

LIFE®

THE
SIMPSONS™
EDITION

For 2 to 6 Players / AGES 9 +

SETTING UP

Carefully snap the buildings, mountains, bridge and spinner from the plastic runners. Discard the runners.

Apply Labels to the Mountains and Bridge

Match the letters next to each of the four labels to the circled letters on the plastic mountains and bridge. Apply the labels to the matching plastic pieces as shown at the left.

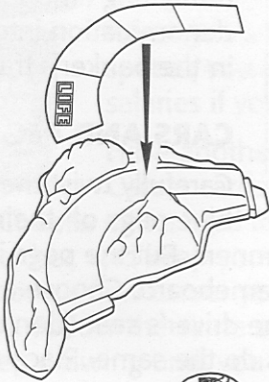

Assemble and Attach Spinner

Attach the Krusty glamor cap to the spinner by pressing the tabs on the bottom of the cap into the holes in the top of the spinner. Punch out the spinner ring from the cardboard sheet. Match the double-notched section of the spinner ring to the double-tabbed section on the underside of the plastic spinner dial (under the number 8). Snap the ring into the dial by sliding the ring under each of the plastic tabs. Next, place the assembled dial onto the green peg in the center of the spinner base. Press the spinner arm into the spinner rim, pointing the spinner arm toward the center of the spinner.

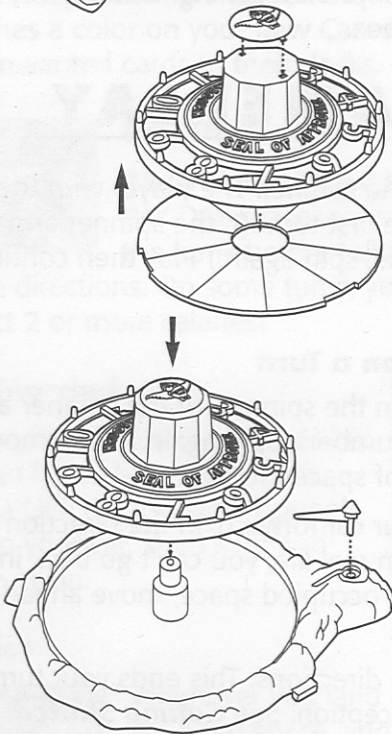

OBJECT

Collect money and LIFE tiles, and have the highest dollar amount at the end of the game.

CONTENTS

- Gameboard
- 6 Plastic car pawns
- Pink and blue "people" pegs
- 3 Mountains
- Bridge
- 7 Buildings
- Label sheet
- Spinner ring, spinner dial, spinner arm, and glamor cap
- Stack of play money, insurance policies and promissory notes
- 25 LIFE tiles
- Deck of 36 cards
- Banker's tray

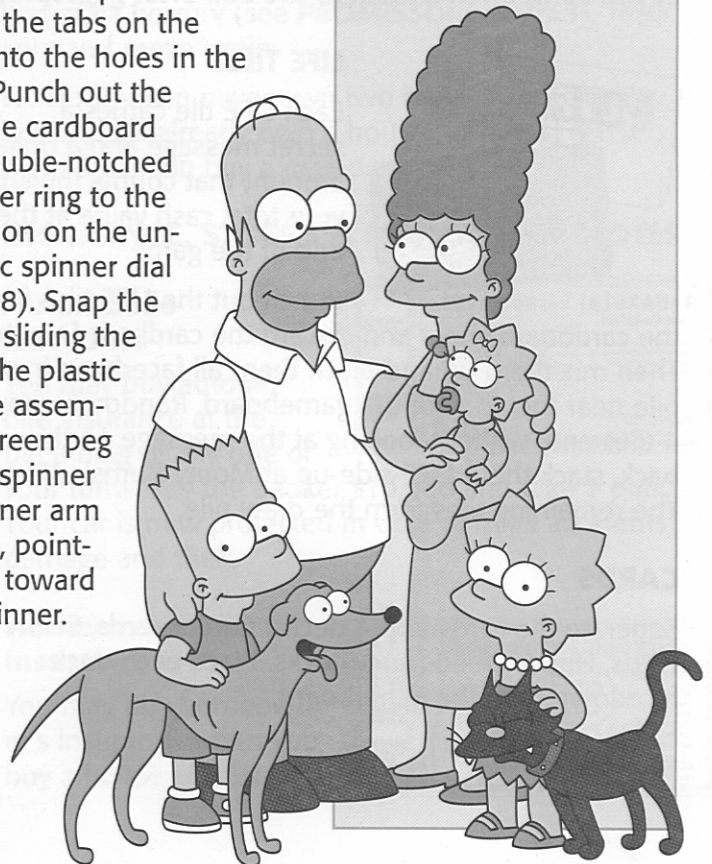

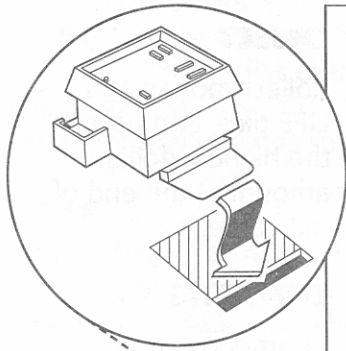

Attach the Buildings, Mountains, Bridge and Spinner

Punch out the small cardboard slots in the gameboard. Discard the cardboard waste. Insert the buildings, mountains, bridge and spinner by matching the circled letters in the plastic pieces to the letters on the gameboard. Slide each piece into place as shown.

Note: You'll need to detach the buildings, mountains, bridge and spinner before storing all of the components back in the box after gameplay.

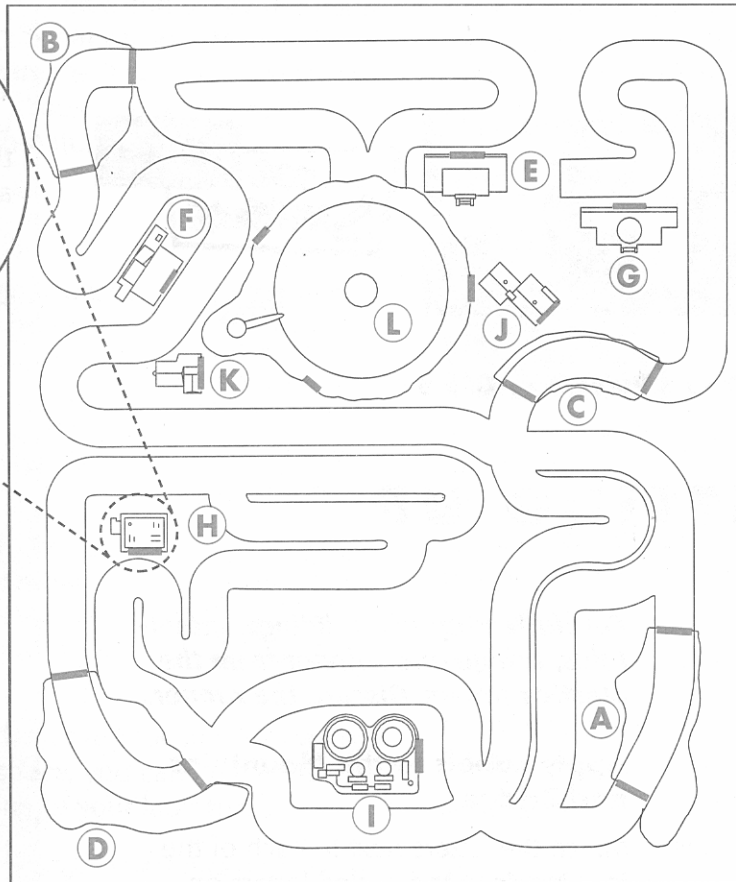

INSURANCE POLICIES & PROMISSORY NOTES

Separate the automobile insurance policies, homeowner's insurance policies and promissory notes. Place each pile separately into the slots in the banker's tray.

MONEY

Choose one player to be the banker. This player is in charge of all money paid to and from the bank.

The banker separates the money into piles by denomination, gives each player \$10,000, then puts the remaining amount of each denomination into the slots in the banker's tray.

CARS AND PEGS

Carefully twist the pink and blue pegs off their plastic runners. Discard the runners. Put the pegs in a pile near the edge of the gameboard. Choose a car and fit a people peg into the driver's seat (don't forget to buckle up!). All players do the same. Place any extra cars back in the box.

LIFE TILES

Each LIFE tile carries a secret message and a dollar amount that counts toward your total cash value at the end of the game.

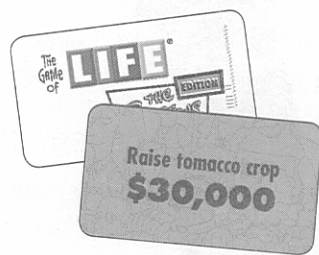

Punch out the LIFE tiles from the cardboard sheet and discard the cardboard waste. Then mix them up and place them all facedown in a pile near the edge of the gameboard. Randomly draw 4 tiles and, without looking at the message on the back, stack them LIFE-side-up at Monty Burns's Manor. The remaining tiles form the draw pile.

CARDS

Separate the cards into 4 decks: Career cards, Salary cards, House Deeds and Stocks. Place each deck facedown near the gameboard.

GAMEPLAY

All players spin the spinner. The player with the highest spin takes the first turn. (If the spinner arm stops between numbers, spin again.) Play then continues clockwise.

What You Do on a Turn

On your turn, spin the spinner. (If the spinner arm stops between numbers, spin again.) Then move your car the number of spaces shown.

Always move your car forward, in the direction of the arrows. (Just as in real life, you can't go back in time!) If you land on an occupied space, move ahead to the next open space.

Follow the space directions. This ends your turn. Your first turn is an exception. See **Getting Started**.

Getting Started

On your first turn, decide either to GET A JOB, or to GET AN EDUCATION. An education offers more career and salary options, but it takes time - and it puts you in debt!

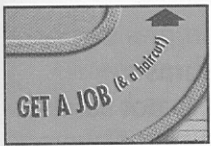

GET A JOB

If you decide to get a job, place your car on the GET A JOB space, then do the following:

Draw a Career Card: Have another player fan out the Career card deck facedown, while you draw 1 card at random. NOTE: You may not keep a Career card that says, "Degree Required." If you draw one of these cards, draw again!

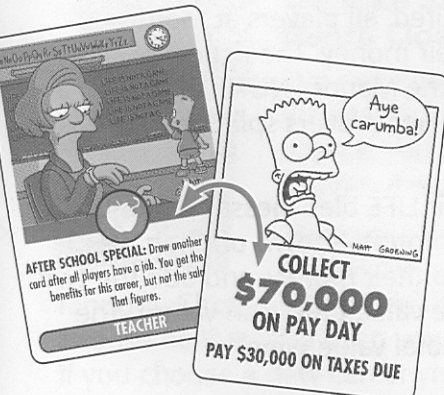
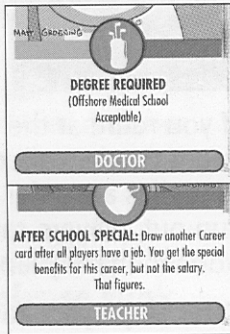

In order to keep this Salary card you must have a Career card with green on it.

Draw a Salary Card: Now have the same player fan out the Salary card deck facedown while you draw 1 card at random. Compare the color on the Salary card to the colors on your Career card. If the colors match, keep the Salary card. If the colors do not

match, then randomly draw a new Salary card. NOTE: Your Salary card does not have to match both of the colors on your Career card, just one of them.

Place your Career card and your Salary card faceup in front of you. Now spin and move as you would on a regular turn.

GET AN EDUCATION

If you decide to get an education, place your car on the GET AN EDUCATION space. Borrow \$100,000 for tuition (see **PROMISSORY NOTES**). Now spin and move as you would on a regular turn.

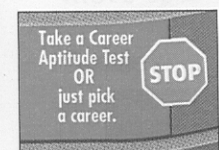
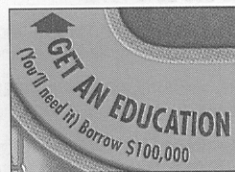

CAREER CHOICE

When you reach the JUST PICK A CAREER space, STOP! - even if you have moves left. Then do the following:

Choose Your Career Card: Have another player fan out the Career card deck facedown, then draw 3 cards at random. Look at the cards, choose any 1 card, then

return the other 2 cards to the deck. See the **CAREER GUIDANCE** section, below.

Choose Your Salary Card: Now have the same player fan out the Salary card deck facedown while you draw 1 card at random. Compare the color on the Salary card to the colors on your Career card. If the colors match, keep the Salary card. If the colors do not match, then randomly draw a new Salary card. NOTE: Your Salary card does not have to match both of the colors on your Career card, just one of them.

Place your Career Card and your Salary Card faceup in front of you. Now spin and move again.

Career Guidance

How much money you earn depends not only on the amount of your salary, but also on how often players land on your Career Spaces (spaces with symbols that match your Career card). For example, if you're the Public Servant, players must pay you whenever they land on "Taxes Due" Career Spaces.

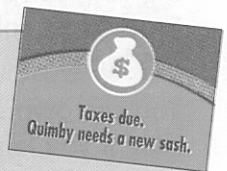

THE SPACES Space Colors

As you move your car, notice the space colors - they're important! Here's what the colors mean:

Orange Spaces

Most spaces are orange. Whenever you land on an orange space, you must follow the directions.

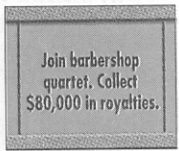

Blue Spaces

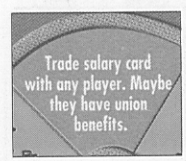

These spaces are optional. Whenever you land on a blue space, follow the directions only if you want to. If the space allows you to take a salary from another player, you do not have to match the color on the new Salary card to a color on your Career card. Just take the other player's Salary card, place it faceup in front of you and give that player your Salary card.

Green Spaces

These are PAY DAY spaces. Whenever you land on or pass a PAY DAY space, collect your salary from the bank.

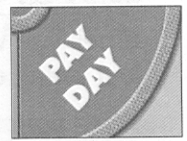

Red Spaces



There are 4 of these spaces: JUST PICK A CAREER, GET MARRIED, BUY A HOUSE, and SELL HOUSE & BUY

A NEW ONE. Whenever you reach a red space, STOP! — even if you have moves left. Follow the directions, then spin and move again. Red spaces have special directions, which are explained separately.

Life Spaces

Whenever you land on a LIFE space, take 1 LIFE tile from the draw pile. If the draw pile runs out, take 1 LIFE tile from any other player. Do not look at the back of the LIFE tile. Place it LIFE-side-up in front of you.

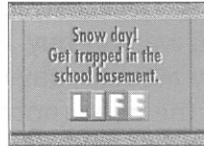

Career Spaces

The symbols on these spaces match those on the Career cards. Players earn money from opponents who land on their Career spaces. When you land on a Career space, do the following:

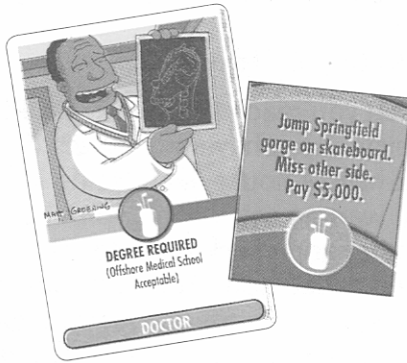

- If an opponent has the matching Career card, pay that player the amount on the space.
- If you have the matching Career card, pay nothing.
- If no player has the matching Career card, pay the bank the amount on the space.

For example, the Jump Springfield gorge on skateboard space is one of the Doctor's Career spaces. If you land there, pay \$5,000 to the player who has the Doctor Career card.

Taxes Due Spaces

These are the Public Servant's Career spaces. If you land on a Taxes Due space, pay the Public Servant the taxes shown on your Salary card. If you are the Public Servant, you pay nothing. If there is no Public Servant, pay the bank.

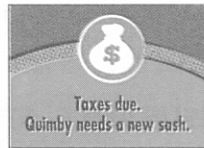

Special Rules for Careers

Most careers have special rules enabling you to do something different or get money in a different way. Here are the rules for the different careers.

Police Officer

Speed Trap: Any opponent caught speeding (spinning 10) must pay the Police Officer \$10,000! It's up to the Police Officer to notice when a player spins a 10. If you don't notice, the "speeder" gets away and pays no fine. NOTE: If there is no Police Officer in the game, there is no fine for spinning 10.

Entrepreneur

Worst Investment Ever: Any time an opponent buys a stock card or insurance policy, you get a \$5,000 commission. Take \$5,000 out of the money paid to the bank for the card or policy, the rest goes to the bank. NOTE: Your commission comes from the money used to buy the card or policy — the player buying does not have to pay an additional \$5,000.

TV Star

Ratings Bonanza: If two spins in a row are matching 8s, 9s, or 10s, you got the break you've been waiting for. Replace your Salary card with the one that has yellow on it (trading with another player if necessary). It doesn't matter that your Career card doesn't have yellow on it! IMPORTANT: The two numbers spun must be identical — so a 9 and then a 10 doesn't work but an 8 and then another 8 does! It doesn't matter if the two spins are by two different players or the same player. It's up to you to notice when players spin these matching numbers. If you don't notice, you miss your big break.

Teacher

After School Special: After all players have drawn their Career cards, you may draw a second one. Shuffle the Career card deck, place it facedown near the gameboard and draw the top card. This is your summer job! You don't get a salary for this second career, but if someone lands on a Career space for it, you get the money as if it was your primary career.

Nuclear Technician

Meltdown: Any time the spinner stops between numbers or comes off the track, collect \$50,000 from the bank to fix it. This only applies if another player spins the spinner off the track — if you spin it off, you have to fix it for free. It's up to you to notice when players spin off the track. If you don't notice, you don't get paid.

Personal Assistant

Brown Nose Bonus: Your hard work has finally paid off. At the start of your turn, you may trade in 4 LIFE tiles for the Salary card with yellow on it (trading with another player if necessary). It doesn't matter if your Career card doesn't have yellow on it! You may not look at the LIFE tiles before turning them in. Return the LIFE tiles, facedown, to the draw pile.

Service Sector Employee

Come Again! For selling the winning Stock card, collect \$10,000 from any player spinning a "1." It's up to you to notice when players spin a "1." If you don't notice, you lose out.

Changing Careers

When you land on either of these spaces, you must trade your Career card and Salary card for new ones.

Have another player fan out the Career card deck facedown. Draw 1 card at random. NOTE: If you didn't get an education, you may not keep a Career card that says "Degree Required."

Then do the same to draw a new Salary card. Keep drawing until you draw a Salary card that matches a color on your new Career card. Now return your previously held cards to their decks.



Take an Orange Eating Class OR Take Self Defense Funk Dance Class

The benefits of further education... When you land on either of these spaces, you may change careers and salaries if you wish to do so.

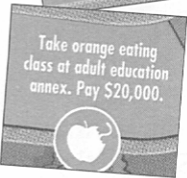

Have another player fan out the Career cards. Draw 2 cards at

random. Choose either card for your new career; or choose neither, and keep your current Career card. If you choose a new career you must also choose a new salary. Follow the same steps with the Salary cards. Keep drawing until you draw a Salary card that matches a color on your new Career card. Then return the unwanted cards to their decks.



Pay Day

Whenever you land on or pass over a PAY DAY space, collect your salary from the bank before following any other

space directions. On some turns, you may be able to collect 2 or more salaries!

Get Married

When you reach this space, STOP! — even if you have moves left. Take a LIFE tile and add 1 people peg to your car. Then spin and move again.

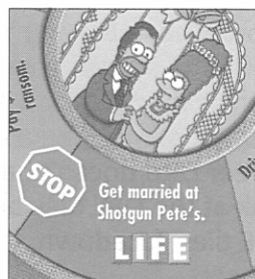

Babies



Whenever you land on a It's a Boy or It's a Girl space, add 1 people peg to your car. If you land on a Twins! space, add 2 people pegs to your car. On all of these spaces, take a LIFE tile too!

Buy a House

When you reach this space, STOP! — even if you have moves left. Draw 2 House Deeds at random from the deck. Decide which one, if either, you want to buy. If you decide to buy a house, pay the bank the price on the deed (not the insurance amount; that's a separate transaction). If you're short on cash, you must borrow (see **PROMISSORY NOTES**). Now spin and move again.



Sell/Buy a House

When you reach this space, STOP! — even if you have moves left. If you have a house, first decide if you want to sell it. If so, spin the spinner and check your House Deed to see how much you can sell your house for. Sometimes you will make money, sometimes you will lose money and sometimes you will just break even. Now decide if

If you draw this card, pay the banker \$120,000. If you sell this house, spin the spinner. If you spun a 5, you'd sell for \$130,000.



you want to buy a house (you may also buy a house now if you didn't earlier in the game). If you do buy a new house, draw 2 House Deeds at

random from the deck. Decide which one, if either, you want to buy. If you decide to buy one, pay the bank the price on the deed (not the insurance amount; that's a separate transaction). If you're short on cash, you must borrow (see **PROMISSORY NOTES**). Then spin and move again.

NOTE: You can never own two houses at the same time. If you already own a house, you must sell it before you can buy a new one.

INSURANCE, STOCKS & PROMISSORY NOTES

Automobile Insurance

You may buy automobile insurance at the beginning of any one of your turns. Pay the banker \$10,000 and take 1 policy. Your car is now protected in case of freak accidents, damage and theft.

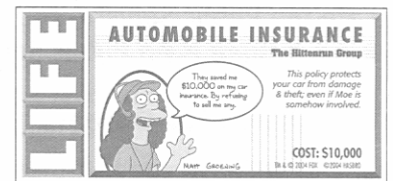

Homeowner's Insurance

You may buy homeowner's insurance when you buy a house — or at the



beginning of any one of your later turns. Pay the banker the insurance amount shown on your House Deed and take 1 policy. (For example, if you own Wolfcastle Wolf Castle, pay \$50,000.) You're now protected in case of natural and not-so-natural disasters.

Stocks

You may buy 1 Stock at the beginning of any one of your turns. Pay the banker \$50,000 and take 1 Stock of your choice from the deck. Whenever any player (including you) spins the number on your Stock card, collect \$10,000 from the bank!

You can own only 1 Stock. Exception: If you land on the Join the Investorettes space, take 1 Stock (at no charge) even if you already own one!

If you lose your only Stock on the Blowfish Poisoning or Owe Fat Tony a Favor space, you can buy a new one at the beginning of any one of your later turns.

Promissory Notes

You may borrow money from Fat Tony during any one of your turns. Take 1 or more Promissory Notes (each note is worth \$20,000). The banker gives you the matching amount from the bank.

Repay all loans to the bank (with \$5,000 interest each) when you retire, or during any turn before then.

RETIREMENT

When you reach the RETIRE space, STOP! — even if you have moves left. Then do the following:

- Repay to the bank any, and all, outstanding notes.
- If you have a house, sell it. Spin the spinner and check your house card to see how much you sell your house for. Sometimes you will make money, sometimes you will lose money, and sometimes you will just break even.
- Place your Career card, Salary card, and Insurance Policies (if any) out of play. Keep your Stock — you can still collect when players spin your number!

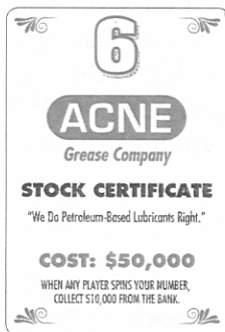

If you choose the Number 6 Stock, collect \$10,000 from the bank whenever the 6 is spun.

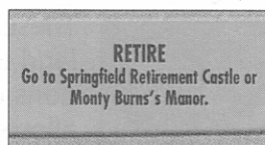

- If you think you might have the most money, place your car on Monty Burns's Manor (any number of players may retire there). Otherwise, place your car on Springfield Retirement Castle.
- Wherever you decide to retire, wait there until all other players have retired.

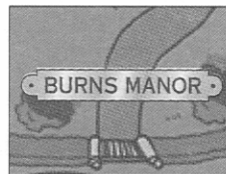

If you retire at Monty Burns's Manor, your LIFE tiles are not safe! If the draw pile has run out, players may take tiles from you when they land on LIFE spaces.

If you retire at the Springfield Retirement Castle, collect 1 LIFE tile. Your LIFE tiles are safe! If the draw pile has run out, players cannot take tiles from you when they land on LIFE spaces.



After all players have retired, all players at Monty Burns's Manor count their money. The richest player takes the 4 LIFE tiles at the Manor. NOTE: In case of a tie for richest player, the tied players split the pile (take 2 tiles each).

Now all players turn their LIFE tiles message-side-up and add up the dollar amounts shown on their tiles. All players then count up their money, and add the two figures together (LIFE tile value plus cash value). The player with the highest total value wins!

Game adapted by Patric M. Verrone with grateful recognition to Matt Groening, James L. Brooks, Sam Simon, Al Jean, Mike Reiss, David Mirkin, Bill Oakley, Josh Weinstein, Mike Scully and all the writers of the most original television show in history.

US and Canadian Consumers:

We will be happy to hear your questions or comments about this game. Write to: Hasbro Games, Consumer Affairs Dept., P.O. Box 200, Pawtucket, RI 02862. Tel: 888-836-7025 (toll free). Canadian consumers please write to: Hasbro Canada Corporation, 2350 de la Province, Longueuil, QC Canada, J4G 1G2.

European Consumers:

Should you have any difficulty with this product, write to us at: Hasbro UK Ltd., Hasbro Consumer Affairs, P.O. Box 43, Caswell Way, Newport, Wales, NP19 4YD, or telephone our Helpline on 00 800 2242 7276.

"THE SIMPSONS" TM & © 2004 Twentieth Century Fox Film Corporation. All Rights Reserved.

The HASBRO, MILTON BRADLEY and MB names and logos, THE GAME OF LIFE, and these rules are ® & ©2004 Hasbro, Pawtucket, RI 02862. All Rights Reserved. 41648

Distributed in the United Kingdom by Hasbro UK Ltd., Caswell Way, Newport, Gwent NP9 0YH. Distributed in Australia by Hasbro Australia Ltd., 570 Blaxland Road, Eastwood NSW 2122, Australia. Tel: (02)9874-0999. Distributed in New Zealand by Hasbro New Zealand Ltd., Albany Heights, Auckland, P.O. Box 100 940, North Shore Mail Centre, Auckland, New Zealand 1333. Tel: (649) 415-9916.



PROOF OF PURCHASE

