

The  
Game  
of

LIFE



EDITION

2 to 4 PLAYERS

AGES 7+

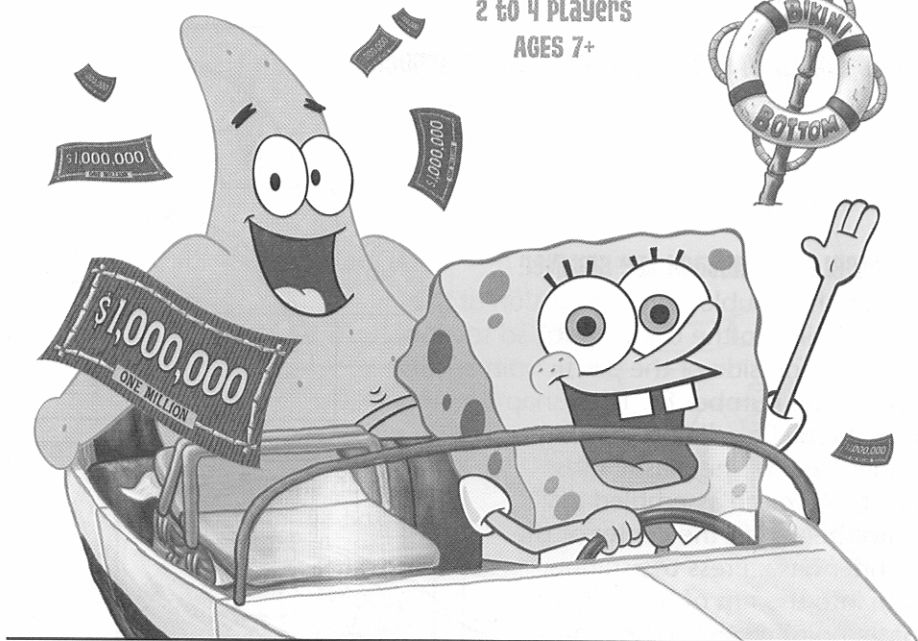

## OBJECT

Journey through LIFE in Bikini Bottom and do all of the things that SpongeBob and his friends do. Start a career and get paid; collect LIFE tiles and win raffles; rent a home, pay expenses, and adopt a pet. At the end you'll be able to kick back and relax at the Shady Shoals Rest Home; hopefully as the winner, with the highest net worth.

## CONTENTS

- Gameboard • 4 Plastic SpongeBob character pawns (SpongeBob SquarePants, Patrick, Squidward, Mr. Krabs) • 3 Mountains • Bridge
- 6 Buildings • Spinner base, spinner dial, spinner arm, and spinner ring
- Stack of play money • 50 LIFE tiles • 78 Game cards • Banker's tray
- Label sheet

## ASSEMBLY

- Carefully twist and snap off the plastic pieces from the runners. Discard the runners.
- Remove the pieces from the plastic bags. Discard the bags.
- Carefully punch out the LIFE tiles and spinner ring from the cardboard parts sheet. Discard the cardboard waste.

### APPLY LABELS TO THE MOUNTAINS AND THE BRIDGE.

Match the letters next to each of the four labels to the letters molded on the plastic mountains and bridge. Apply the labels as shown in Figure 1.

### ASSEMBLE AND ATTACH THE SPINNER:

Match the double-notched section of the spinner ring to the double-tabbed section on the underside of the plastic spinner dial (under the number 8). Then snap the ring into the dial by sliding the ring under each of the plastic tabs. Next, place the assembled dial onto the peg in the center of the spinner base. Press the spinner arm into the rim of the spinner base, pointing the spinner arm toward the center of the spinner. See Figure 2.

### ATTACH BUILDINGS, MOUNTAINS, BRIDGE AND SPINNER TO THE GAMEBOARD.

Punch out the small cardboard slots in the gameboard. Insert the buildings, mountains, bridge and spinner by matching the letters in the plastic pieces to the letters on the gameboard. Slide each piece into place as shown in Figure 3.

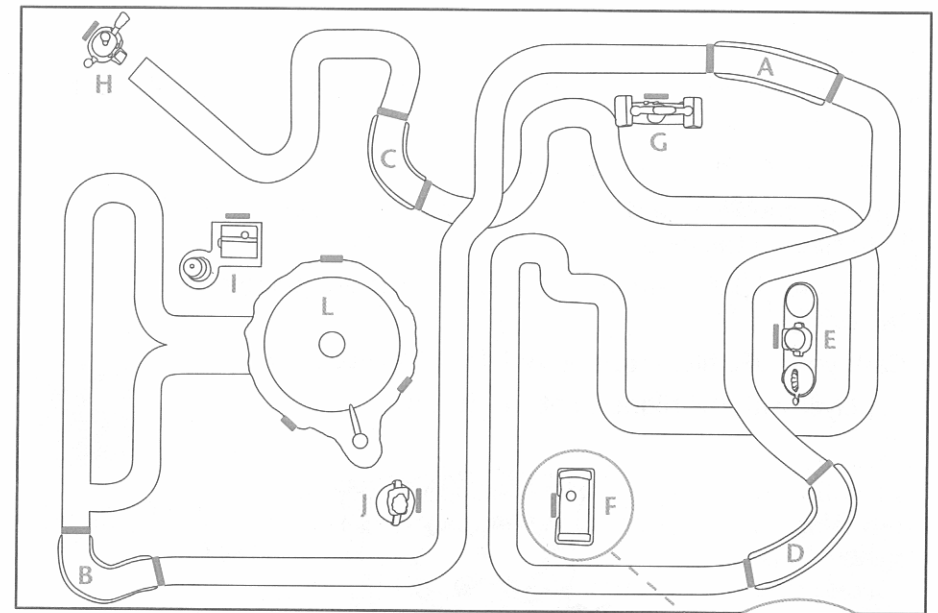
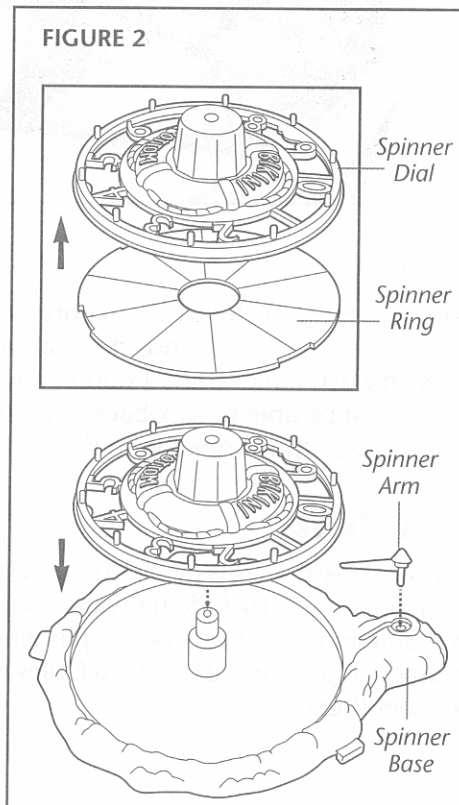
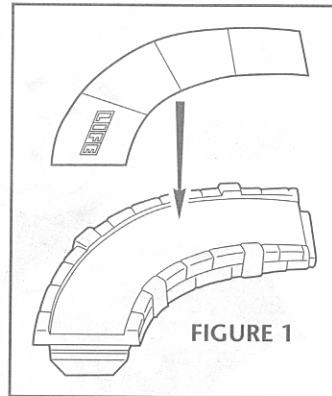

FIGURE 3

**Note:** You'll need to detach the buildings, mountains, bridge and spinner from the gameboard before storing the game back in the box.

### LIFE TILES

Place the LIFE tiles in a pile near the banker's tray.

**NOTE:** LIFE tiles count toward your score total at the end of the game.

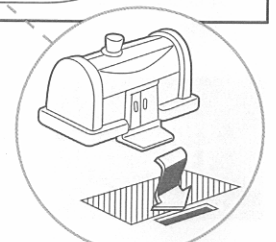

## GAME SETUP

### CARDS

Separate the cards into 6 decks: Career cards, Pet cards, Home cards, Life cards, Expense cards, and Raffle cards. Place each deck facedown near the gameboard within reach of all players.

### MONEY

Choose one player to be the banker. This player is in charge of all money paid to and from the Bikini Bottom bank. The banker separates the money into piles by denomination, and places the piles into the Banker's Tray. Each player is then given 5 \$100s to begin. **NOTE:** The banker must keep his/her money separate from the bank's money.

## GAMEPLAY

Each player chooses a character pawn, then spins the spinner. The player spinning the highest number goes first. Play then continues in a clockwise direction.

### WHAT TO DO ON A TURN.

On your turn, spin the spinner and move your character pawn the number of spaces indicated. (If the spinner arm stops between numbers, spin again.) NOTE: You must move the full amount of the spin, unless along your travels, you reach a dark orange EVENT space. (See DARK ORANGE — EVENT SPACES below.)

Always move your character pawn forward, in the direction of the arrows. (Just as in real life, you can't go back in time!) If your move ends on an occupied space, move ahead to the next open space. Follow the instructions on the space or draw a card and follow its instructions. This ends your turn.

### GETTING STARTED

On your first turn, decide to *either* start a career immediately, or go to college. Going to college offers different (and sometimes higher paying) career opportunities, but it does take more time!

#### Start career

If you decide to jump right in and start your career, place your character pawn on the START CAREER space. Now spin the spinner and move as you would on a regular turn.



#### Start college

If you decide to take some time and go to college before starting your career, place your character pawn on the START COLLEGE space. Now spin the spinner and move as you would on a regular turn.



### THE GAMEBOARD

As you travel through Bikini Bottom, take notice of the different space colors and pictures — they are important! Here is a quick look at some of these spaces.



### DARK ORANGE — EVENT SPACES:

There are 3 types of EVENT spaces: CAREER CHOICE, ADOPT A PET and PICK A HOME. Whenever you reach a dark orange EVENT space, you must STOP — hence the STOP sign — even if you have moves left. See below for instructions on these spaces.

- **CAREER CHOICE** — Let's get to work! What type of job would you like? Do you want to be an Ice Cream Vendor, a Mail Carrier, or maybe a Fry Cook? Land on the CAREER CHOICE space and choose your career. Have another player fan out the CAREER card deck, facedown,

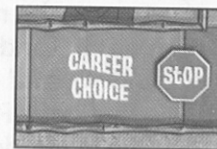

and randomly draw 2 cards. Each card indicates a career and a salary. Look at the cards carefully and choose the job that's right for you. Return the other card, facedown, to the deck. Place your CAREER card faceup in front of you. Now spin the spinner and move as you would on a regular turn.

**NOTE:** You *cannot* keep a CAREER card that says "College" unless you've gone to college. So, if you draw one of these cards, and you haven't gone to college, you'll have to put it back in the pile and draw another one.

- **ADOPT A PET** — Land on the ADOPT A PET space and you get to choose a pet to travel with you on LIFE's little journeys. There are some wonderful pets up for adoption, and they all come house-trained. Have another player fan



out the PET card deck, facedown, and randomly draw 2 cards. Look at the cards and choose your favorite pet. Maybe you'll pick Birdy or the 4-Stinger Jellyfish. Or maybe Wormy or the Giant Clam will catch your eye. Return the card you don't choose to the deck. *Pay the bank the adoption fee* indicated on the card you did choose and place the card faceup in front of you. Now spin the spinner and move as you would on a regular turn.

- **PICK A HOME** — Is your idea of the perfect home a Cave, Grandma's House or the Flying Dutchman's Ship? Land on the PICK A HOME space and you get to choose. Have another player



fan out the HOME card deck, facedown, and randomly draw 2 cards. Each card will show a house and its monthly rent. Look at the cards and choose your Home Sweet Home. Return the other card to the deck. *Pay the bank your first month's rent* and place the card faceup in front of you. Now spin the spinner and move as you would on a regular turn.



### ORANGE — LIFE SPACES:

LIFE experiences are always worth something! LIFE cards show a variety of activities you can do in Bikini Bottom. Whether you enter the Krabby Patty flipping contest or invent inflatable shorts, each card indicates

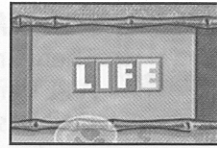

the number of LIFE tiles you earn for being an active citizen. Land on a LIFE space and draw the top card from the LIFE card deck. Read the card and collect the indicated number of LIFE tiles from the bank. Set these LIFE tiles aside for now but don't forget about them. LIFE tiles are very important and are used in scoring at the end of the game. Return the LIFE card to the bottom of the LIFE card deck. Your turn ends.



### LIGHT GREEN — RAFFLE SPACES:

Do you feel lucky? You could win an unlimited supply of Grandma's homemade cookies, a subscription to *Fancy Living Digest* or even a new bicycle. If you land on a RAFFLE space, draw the top card from the RAFFLE card deck. If you decide to enter the raffle, purchase the ticket from the bank for \$100. Then: Spin the Spinner, 'round she goes. Where she stops nobody knows. If the spinner stops on any number matching one shown on your raffle ticket, you win and get to keep the ticket. RAFFLE cards are used in scoring at the end of the game. If you don't match any of the raffle numbers on the ticket, it's OK. Better luck next time. Simply return the ticket to bottom of the RAFFLE card deck. Your turn ends.

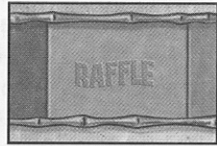

### PURPLE — SPIN AGAIN SPACES:

When you land on one of these spaces, spin the spinner and move again.

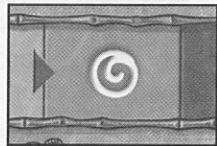

### RED — PAY DAY SPACES:

Hip Hip Hooray! It's finally PAY DAY! Land on or pass over a PAY DAY space and collect, from the bank, the salary indicated on your CAREER card.

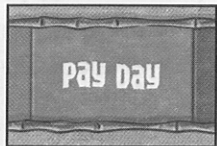

### YELLOW — CHANGE JOBS SPACE:

If your first career choice wasn't all you thought it'd be, here's your chance to change. You may want to give up your budding career as an Ice Cream Vendor for that once-in-a-lifetime chance to be a Cashier.



Whenever you land on a yellow CHANGE JOBS space you have a chance to get a higher paying job. Have another player fan out the CAREER card deck, facedown, and randomly draw 2 cards. Look at the two new cards and compare them to the career you already have. Choose a new career or keep your existing one, and return the remaining cards to the deck.

**NOTE:** These spaces are optional. If you are happy with the job you have, you can choose not to change.

### DARK GREEN — EXPENSE SPACE:

LIFE is full of little surprises... and sometimes they are costly ones. You just can't live without a new reef blower. You just got stung by a jellyfish. You have a bad case of the suds and have to go to the hospital. EXPENSE cards represent real LIFE Bikini Bottom expenses. When you land on an EXPENSE space, draw the top card from the EXPENSE card deck. Pay the bank the amount indicated on the card and return it to the bottom of the EXPENSE card deck.

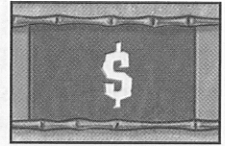

### BLUE — RENT SPACE:

Nothing in LIFE is free. So when you land on a RENT space, you must pay the bank the rent amount indicated on your HOME card.

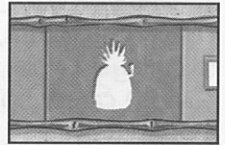

### MONEY

If a player runs out of money, continue play without building debt. Expense amounts and rent payments for that player will be excused while the player is unable to pay. The player will, however, continue to spin and move. Players cannot participate in raffles if they cannot pay for a ticket.

### LIFE TILES

If the bank runs out of LIFE tiles, players may cash in theirs, for \$100 dollars each, to restore enough tiles to complete the game.

### SHADY SHOALS REST HOME

By now you must be ready for a little rest and relaxation. How about kicking back and eating Krabby Patties at the Shady Shoals Rest Home? When you reach the SHADY SHOALS REST HOME space, stop — even if you have moves left. Now on your turn, spin the spinner. If you spin a 10, earn a free RAFFLE card. Now spin again to see if you've won! If you don't spin a 10, end your turn. Better luck next time.



# WINNING

After all players have reached the Shady Shoals Rest Home, cash out by doing the following:

- Place your CAREER and PET cards out of play.
- Cash your RAFFLE card(s) into the bank for the dollar value of the item indicated on the card.
- Cash your HOME card into the bank for the amount indicated on the card.
- Cash your LIFE tiles into the bank for \$100 each.

The player with the highest net worth wins!

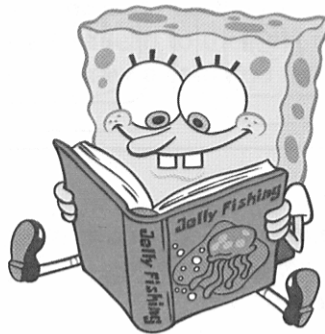

We will be happy to hear your questions or comments about this game. US consumers please write to: Hasbro Games, Consumer Affairs Dept., P.O. Box 200, Pawtucket, RI 02862. Tel: 888-836-7025 (toll free). Canadian consumers please write to: Hasbro Canada Corporation, 2350 de la Province, Longueuil, QC Canada, J4G 1G2. European consumers please write to: Hasbro UK Ltd., Hasbro Consumer Affairs, P.O. Box 43, Caswell Way, Newport, Wales, NP194YD, or telephone our Helpline on 00 800 2242 7276.

© 2005 Viacom International Inc. All rights reserved. Nickelodeon, SpongeBob SquarePants and all related titles, logos and characters are trademarks of Viacom International Inc. Created by Stephen Hillenburg.

The HASBRO, MILTON BRADLEY and MB names and logos, THE GAME OF LIFE, and these rules are ® & ©2005 Hasbro, Pawtucket, RI 02862. All Rights Reserved. TM and ® denote Reg. US Pat. & TM Office. 42454-I



Not suitable for children under 3 years  
because of small parts - choking hazard.

**HASBRO.COM**  
FOR NEW PRODUCTS AND OFFERS

