



# Lovin' Sounds Nursery™

Thank you for purchasing the Playskool Lovin' Sounds Nursery!  
Includes: High chair/bath unit, clock/monitor unit, crib, 7 legs, crib rail, feeding tray, lamp shade, pretend baby bottle, spoon, pretend food bottle with lid, pretend baby powder bottle, crib corner cap, label sheet and bag with one screw.  
**ADULT ASSEMBLY REQUIRED. PHILLIPS SCREWDRIVER REQUIRED FOR ASSEMBLY AND BATTERY PLACEMENT.**

**CAUTION: This product contains small parts which are necessary for assembly. Prior to and during assembly of this product, keep small parts out of children's reach.**

**Small parts pose a choke hazard to children under 3 years. CAUTION: Components to be assembled have sharp edges (or points). Keep the sharp edged components out of the reach of children until assembly is complete.**

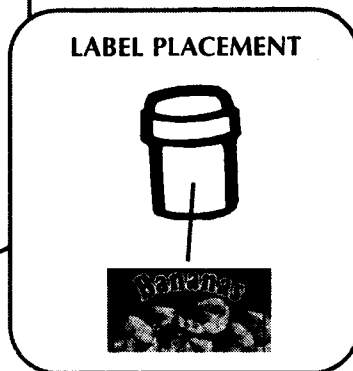
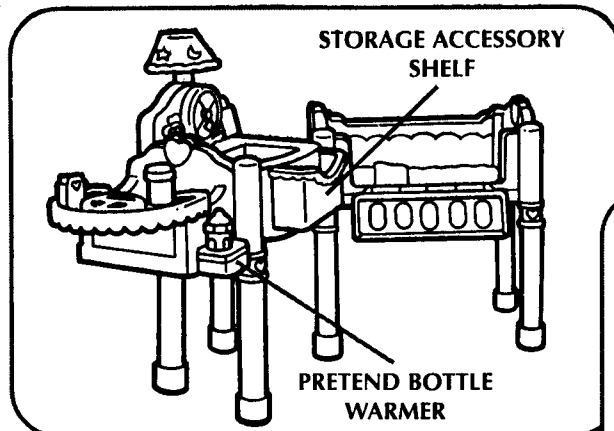

7. Place label on the pretend food jar as shown. The bottle fits into the pretend bottle warmer to the right of the high chair, and all other accessories fit into the storage tray in front of the bath.

### OPERATING THE CLOCK/MONITOR:

When you press the button on the pretend baby monitor, you will hear the sound of a baby crying, then a gentle lullaby will play.

The "clock" is decorated with 4 pictures. Simply point the arrow to a picture and press the center button of the clock hand in, and you will hear the response that matches the picture: "It's snack time!", "It's bath time!", "It's diaper time!" When "It's bedtime!" is selected, a soothing lullaby will play, and the night lamp will light up.

### FCC RULES FOR A CLASS B DIGITAL DEVICE

This equipment has been tested and found to comply with the limits for a Class B digital device, pursuant to Part 15 of the FCC Rules. These limits are designed to provide reasonable protection against harmful interference in a residential installation. This equipment generates, uses, and can radiate radio frequency energy, and, if not installed and used in accordance with the instructions, may cause harmful interference to radio communications. However, there is no guarantee that interference will not occur in a particular installation. If this equipment does cause harmful interference to radio or television reception, which can be determined by turning the equipment off and on, the user is encouraged to try to correct the interference by one or more of the following measures:

- Reorient or relocate the receiving antenna.
- Increase the separation between the equipment and receiver.
- Consult the dealer or an experienced radio/TV technician for help.

© 1995 Hasbro, Inc., Pawtucket, RI 02862 USA. All Rights Reserved.  
© denotes Reg. U.S. Pat. & TM Office.  
**MADE IN THE USA. ELECTRONIC UNIT MADE IN CHINA.**

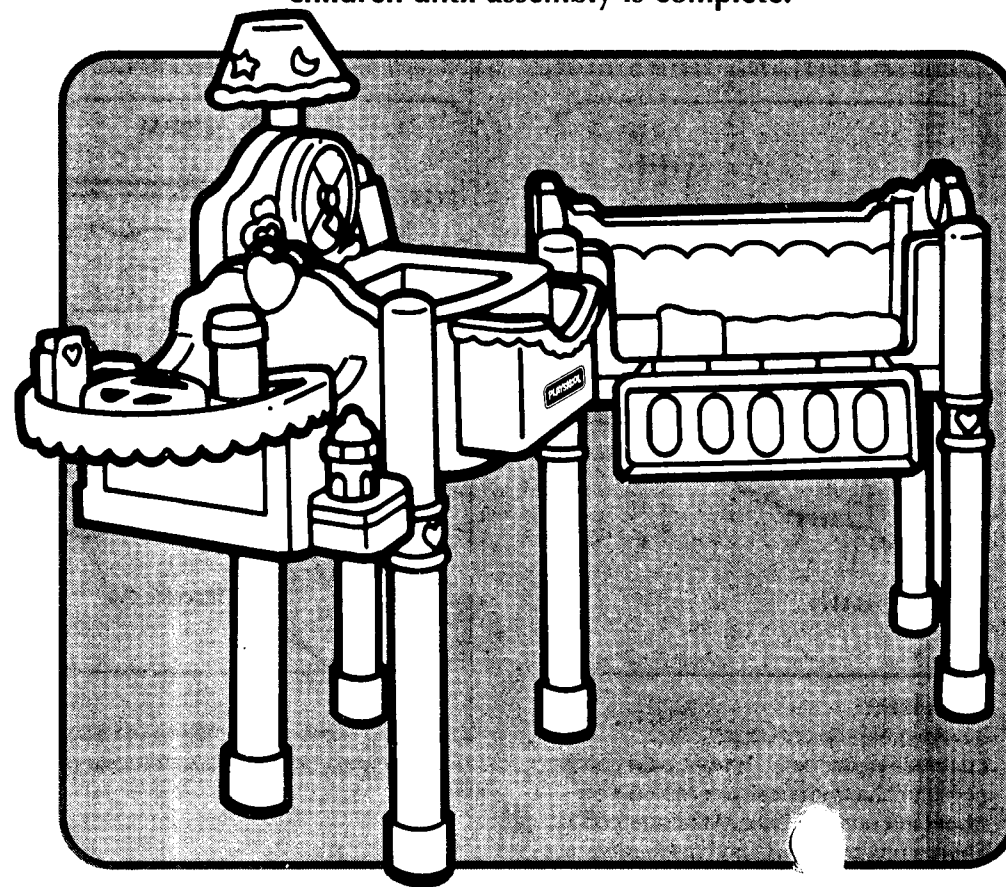

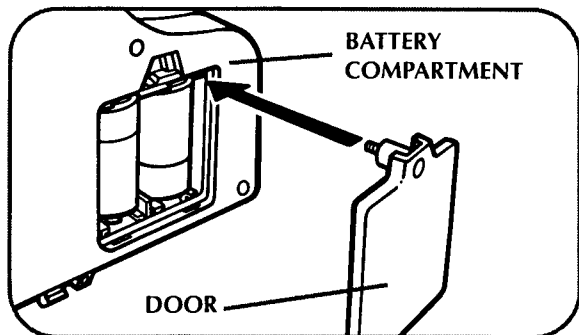

**PLACING THE BATTERIES:**

The battery compartment is located in back of the clock. Use a Phillips screwdriver (not included) to loosen the screw that secures the battery compartment door and remove door. Insert 2 "C" batteries (alkaline recommended) into the battery compartment, following direction indicators inside compartment. Replace door and fasten with the screwdriver.

**CAUTION: TO AVOID BATTERY LEAKAGE**

1. Be sure to insert the batteries correctly and follow the toy and battery manufacturer's instructions.
2. Never mix old batteries with new batteries, or standard (carbon-zinc) with alkaline batteries.
3. Always remove exhausted or dead batteries from product.
4. Remove batteries if product is stored for a long period of time.

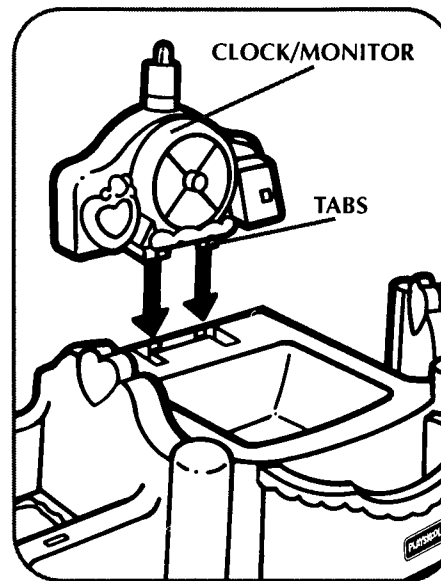

3. Assemble clock/monitor unit into its place behind baby bath. Push straight down as shown to snap tabs on bottom of clock into fittings on main unit.

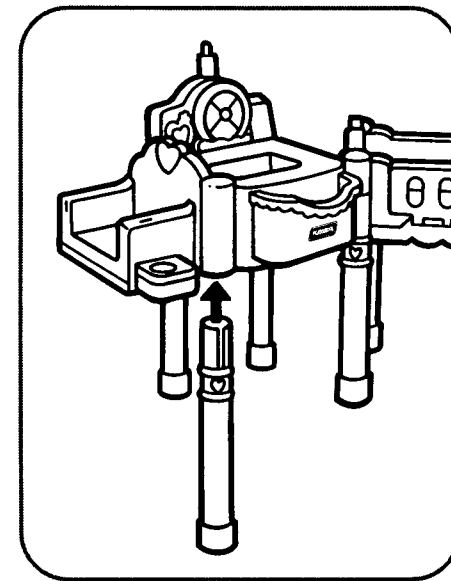

4. Lay assembly on its side, and attach all 7 legs to the nursery. Line up the groove in each leg with the notch in each fitting. Press firmly into place.

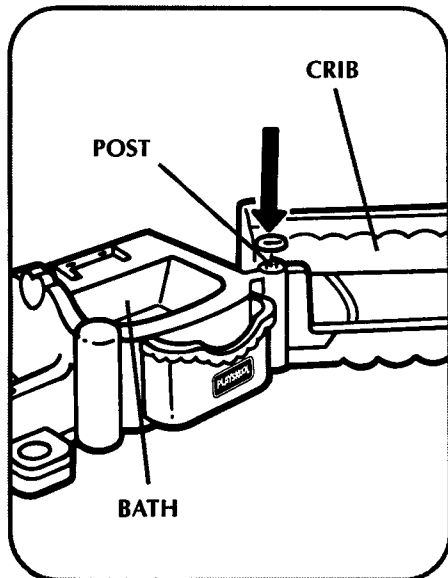

**ASSEMBLY:**

1. Assemble the crib to the high chair/baby bath unit. Fit front right corner of high chair/bath unit over the post on front left corner of crib. Make sure crib is able to pivot forward and back easily.

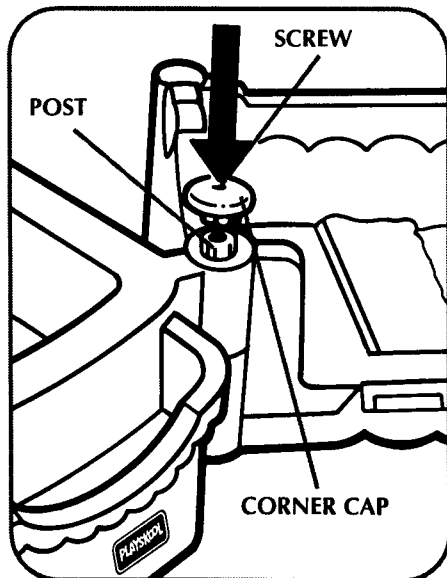

2. Press the corner cap onto top of crib post as shown. Tighten cap onto post with screw.

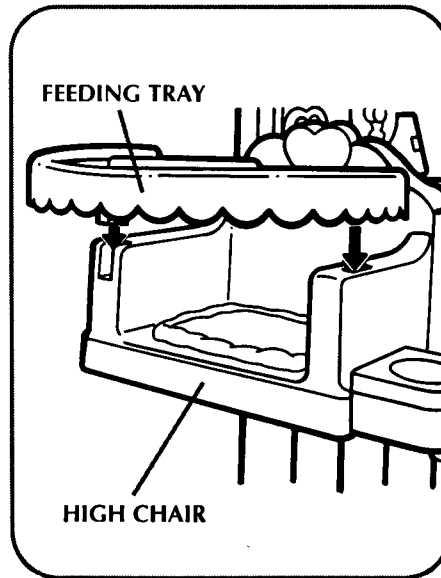

5. Snap the feeding tray onto the front left side of high chair. Make sure that the tray swivels easily from side to side, and into its fitting on right side of chair.

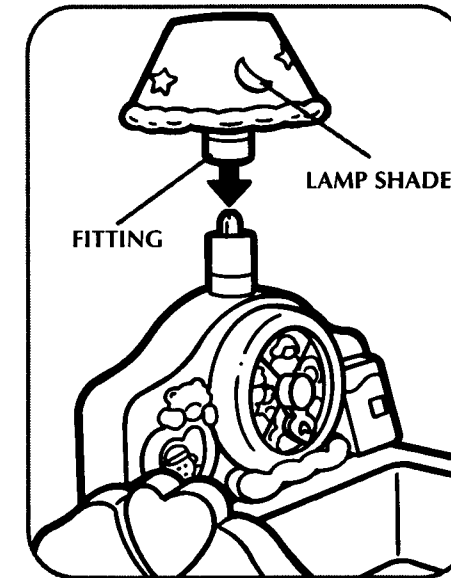

6. Place the lamp shade over bulb on top of clock/monitor, with the extended part of fitting on shade facing front as shown.