

ELECTRONIC

M.C. Hammer

U can't touch THIS

LCD VIDEO GAME

1 THE M.C. HAMMER STORY

Rap music has never been the same since M.C. Hammer blazed onto the scene with the kind of moves no one has ever seen before!

But now there's a chance for a new star to be born. Will it be you? But to be the ultimate rap star, you have to pay your dues!

Can you learn from practice? Can you challenge Hammer and keep up? Can you use your own creativity to create new moves?

Lace up your shoes, listen to the beat, and get ready to move your feet!

2 INSERTING THE BATTERIES

To insert the batteries, remove the battery compartment cover at the back of the game. (To remove cover, push in direction of the arrow.)

Insert two "AA" batteries, UM-3 or equivalent (not included), making sure to align "+" and "-" as shown.

Do not use rechargeable batteries.

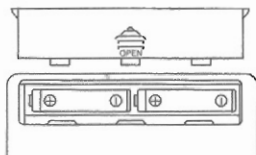

After battery insertion, the ACL switch may be pushed only if the game doesn't work properly. (Use a ball-point pen.) The display should appear as in the diagram below.

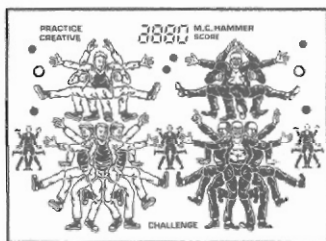

3 CAUTION



High temperature will destroy the unit. Do not leave unit in direct sunlight.



Do not press the liquid crystal display and avoid heavy shock or the display may fail.



Do not use a pencil or pin to press the ACL switch. Use a ball-point pen.



Clean only with a piece of soft dry cloth.

Replace batteries at the first sign of erratic operation.

4 THE OBJECT OF THE GAME

This is your chance to dance with M.C. HAMMER and to become the next rap star! The object of the game is to score as many points as you can!

There are three separate game modes:

In the CHALLENGE MODE, watch M.C. HAMMER dance to the beat. Then it's your turn! Try to dance the same way—or better!

In the CREATIVE MODE, get into the beat—but now you don't follow anyone, not even Hammer! Create your own dance moves!

In the PRACTICE MODE, you can rehearse your moves! Perfecting your moves will enable you to score more points in the CHALLENGE and CREATIVE MODES!

5 CONTROL GUIDE

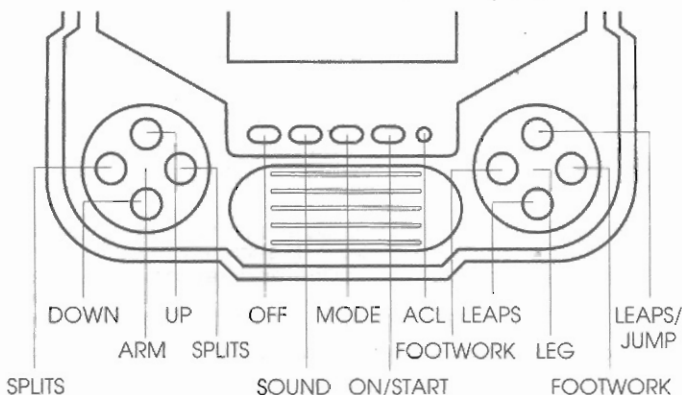

- ON/START —To turn on the unit.
—To start each game mode.
—To start next level in any mode.
- MODE —To select mode in cyclic order:
CHALLENGE ► PRACTICE ► CREATIVE ► CHALLENGE...
- SOUND —To control sound: on or off.
- OFF —To turn off the unit.
- ARM UP (U): —Pressed alone: To move both arms up.
—Plus ARM (L): To raise left arm.
—Plus ARM (R): To raise right arm.
- ARM SPLITS (L): —Pressed alone: Splits left arm.
—Plus ARM (R): Arms split.
—Plus ARM (U): To raise left arm.
—Plus ARM (D): To lower left arm.
- ARM SPLITS (R): —Pressed alone: Splits right arm.
—Plus ARM (L): Arms split.
—Plus ARM (U): To raise right arm.
—Plus ARM (D): To lower right arm.
- ARM DOWN (D): —Pressed alone: To lower both arms.
—Plus ARM (L): To lower left arm.
—Plus ARM (R): To lower right arm.
- LEG
- LEAPS / JUMP (U): —Pressed alone: To leap/jump.
—Plus LEG (L): Left leg split (after leap/jump).
—Plus LEG (R): Right leg split (after leap/jump).
- LEG
- FOOTWORK (L): —Pressed alone: Footwork (both feet) open
—Plus LEG (D): Turn left for side footwork.
Keep pressing for spins (counter-clockwise).
- LEG
- FOOTWORK (R): —Pressed alone: Footwork (both feet) open
—Plus LEG (D): Turn right for side footwork.
Keep pressing for spins (clockwise).
- LEG LEAPS (D): —Pressed alone: Footwork (leg leaps)
—Plus LEG (L): Turn left for side footwork.
Keep pressing for spins (counter-clockwise).

—Plus LEG (R): Turn right for side footwork.
Keep pressing for spins (clockwise).

6 FEATURES

- 3 modes of dance action
- 11 main moves
- built-in rap beat
- multiple arm and leg functions
- sound on/off control
- maximum score retained (in challenge and creative modes)
- built-in automatic power-off timer

7 GAME SUMMARY

There are three modes of dance action!

You choose which mode you want to play: CHALLENGE, CREATIVE, or PRACTICE.

There are two figures that appear on screen—the legendary M.C. HAMMER and your dancer!

You control your dancer—and the computer controls Hammer!

In the CHALLENGE mode, there is a continuous rap beat, and Hammer dances first—and then you try to dance the same way or better to the same music! You score points for each success! There is a total of up to 15 levels!

In the CREATIVE mode, there is also a continuous rap beat, but you create your own way of dancing and following the music! You score points for your creations! There is a total of up to 4 levels!

In the PRACTICE mode, you'll follow M.C. Hammer's actions—but this is your opportunity to get familiar with all of Hammer's moves as well as your control buttons and their corresponding motions! There's no scoring in this mode. But, of course, the more you're able to practice, the better your scoring will be in the CHALLENGE and CREATIVE modes! There is a total of up to 15 levels of practice!

In all three modes, you've got to be the master of the moves:

LEAPS WITH ARMS SPLITS



Key sequence:

- (I) LEG (U)
- (II) ARM (L)
- (III) ARM (R)

LEAPS WITH LEG SIDE SPLITS



Key sequence:

- (I) LEG (U)
- (II) LEG (R) or LEG (L)
- (III) ARM (U) + ARM (R) or ARM (L)

LEAPS WITH SPLITS LEG



Key sequence:

- (I) LEG (U)
- (II) LEG (L) or LEG (R) + ARM (U)
- (III) LEG (R) or LEG (L)

LEAPS SIDE SPLITS



Key sequence:

- (I) LEG (U)
- (II) ARM (R) or ARM (L)

LEAPS WITH SIDE SPLITS LEG



Key sequence:

- (I) LEG (U)
- (II) LEG (L) or LEG (R)
- (III) ARM (U)

DOUBLE SPLITS LEGS AND ARMS



Key sequence:

- (I) LEG (U)
- (II) LEG (L) + ARM (L)
- (III) LEG (R) + ARM (R)

FOOTWORK (OPEN)



Key sequence:

- (I) LEG (L) or LEG (R)
- (II) ARM (U)

FOOTWORK LEAPS LEGS



Key sequence:

- (I) ARM (L)
- (II) ARM (R)
- (III) LEG (D)

SIDE FOOTWORK



Key sequence:

- (I) LEG (D) + LEG (R) or LEG (L)
- (II) ARM (U) + ARM (R) or ARM (L)
- (III) LEG (U) + LEG (L) or LEG (R)
- (IV) ARM (U) + ARM (L) or ARM (R)
- (V) LEG (U) + LEG (R) or LEG (L)

LEAPS SIDE KICK



Key sequence:

- (I) LEG (D) + LEG (R) or LEG (L)
- (II) LEG (U)

SPINS



Key sequence:

- (I) LEG (D) + LEG (R) or LEG (L)
 - (II) LEG (D) + LEG (R) or LEG (L)
- REPEAT TO CONTINUE THE SPIN!

LEAPS SIDE KICK



Key sequence:

- LEG (D) + LEG (R) + LEG (U) or
- LEG (D) + LEG (L) + LEG (U)

SPINS



Key sequence:

- LEG (D) + LEG (R or L) + LEG (D) +
 - LEG (R or L)
- (KEEP REPEATING TO CONTINUE SPIN)

8 HOW TO PLAY

Press the ON/START button to turn on the unit. You'll hear an "On" beep, and the CHALLENGE mode indicator will light up on screen. The maximum score achieved in the CHALLENGE mode will also light up!

It's up to you to choose which mode you want to play—and when you want to play it!

Press the MODE button to select one of the three modes:
CHALLENGE CREATIVE PRACTICE

CHALLENGE MODE:

In the CHALLENGE mode, you'll see both M.C. HAMMER and your own player! You'll hear a continuing rap beat.

HAMMER will dance first!

Then it's your turn! Try to dance the same way as Hammer! Can you repeat his moves? You'll be moving and grooving to the same music! After you try to copy his moves—see if you can dance even better than the legend himself!

There is a total of up to 15 levels! The game is easier and shorter at the lower levels!

You can SCORE up to a maximum of 200 POINTS on each level! Since there are 15 levels, the highest possible maximum score in the CHALLENGE mode is 3000 POINTS!

However, scoring that many points won't be easy! In order to step up to the next level, you have to score more than 100 POINTS on each level!

If you fail to score at least 100 POINTS on any level, the GAME IS OVER! Game also ends after you complete Level 15. Complete Level 15, and you're the champ!

M.C. Hammer, legend that he is, will also score points with successful dance moves, but only your maximum score will be retained!

The game pauses after each level. Press the ON/START button to begin the next level!

After a GAME OVER, press the ON/START button to begin a new game from Level 1!

CREATIVE MODE:

In the CREATIVE mode, there is a continuing rap beat. Listen to the music and create your own way of dancing! You'll score points for your own creation!

There is a total of up to 4 levels! The game (and the music!) is longer in the later levels!

As you create, you'll be scoring points as you go! Your score is added up as you go from level to level, and at the end of the game, your maximum score is retained! That way, you can work on attaining higher and higher standards in the rap profession!

The game pauses after each level. Press the ON/START button to begin each new level!

The GAME IS OVER after you complete level 4! After a GAME OVER, press the ON/START button to begin a new game from level 1!

PRACTICE MODE:

There's no scoring in the PRACTICE mode, but it's your golden opportunity to practice your dance moves as you follow Hammer's actions! Get your moves down in the PRACTICE mode, and then you'll be ready to score even more points in the CHALLENGE and CREATIVE modes!

As in the CHALLENGE mode when you're challenging Hammer instead of just practicing with him, there is also a total of up to 15 levels in the PRACTICE mode!

Move from level to level, trying to capture the glory of Hammer! Before you know it, you'll be ready to match wits (and arms and feet) with Hammer!

After each level, press the ON/START button to begin each new level!

There is a GAME OVER after level 15. Press the ON/START button to begin a new practice game back at level 1!

YOU'RE RIGHT TO SWITCH: After the completion of any stage in any of the three modes of CHALLENGE, CREATIVE, or PRACTICE, you have the right to switch modes!

Just press the MODE button at the end of a stage, and you can switch to the mode of your choice!

When you're in the mode of your choice, press the ON/START button to begin from level 1 of the new mode!

Press the SOUND button at any time to dance in silence. Press it again to regain all the sounds of the dance floor!

Press the OFF button when you're finished playing to turn off the unit. But don't worry if you forget—the unit automatically shuts itself off about three minutes of non-action!

9 DEFECT OR DAMAGE

If a part of your game is damaged or something has been left out, DO NOT RETURN THE GAME TO THE STORE. The store doesn't have replacement parts. Instead, write to us at:

TIGER ELECTRONIC TOYS REPAIR CENTER
980 Woodlands Parkway,
Vernon Hills, Illinois 60061, U.S.A.

In your note, mention the name of your game, the game's model number, and tell us briefly what is the problem. Also include sales slip, date and place of purchase and price paid. We will do our best to help.

10 90-DAY LIMITED WARRANTY

Tiger Electronic Toys warrants to the original consumer purchaser of any of its electronic games that the product will be free of defects in material or workmanship for 90 days from date of purchase.

During this 90-day warranty period the game will either be repaired or it will be replaced (at our option) without charge to the purchaser, when returned either to the dealer with proof of the date of purchase, or when returned prepaid and insured with proof of date of purchase, to Tiger Electronic Toys, 980 Woodlands Parkway, Vernon Hills, Illinois 60061, USA.

Units returned without proof of the date of purchase, or units returned after the 90-day warranty period has expired, will be repaired or replaced (at our option) for a service charge of US\$12.00. Payment must be made by check or money order. This non-warranty service will only be available for one year from the date of purchase. All non-warranty units must be returned postage paid and insured to TIGER ELECTRONIC TOYS, REPAIR CENTER, 980 WOODLANDS PARKWAY, VERNON HILLS, ILLINOIS 60061, USA.

Tiger Electronic Toys will not be liable for loss of use of the product or other incidental or consequential costs, expenses, or damages incurred by the purchaser. Any implied warranties are limited in duration to the 90-day period from the original date of purchase.

This warranty gives you specific legal rights and you may also have other rights which vary from state to state so the foregoing limitations may not apply to you. This warranty does not cover damage resulting from accident, unreasonable use, negligence, improper service or other causes not arising out of defects in material or workmanship.

HOW TO GET SERVICE FROM THE TIGER ELECTRONIC TOYS REPAIR CENTER ON YOUR ELECTRONIC GAME DURING AND AFTER THE 90-DAY WARRANTY PERIOD. During the 90-day warranty period, you may have a defective game replaced at the dealer from which it was purchased. If, however, during the 90-day warranty period, you choose to obtain repair or replacement from the Tiger Electronic Toys Repair Center, please make the arrangements described below:

1) Pack the game carefully in the original box. If the game box is not available, use a good carton with plenty of newspaper, foam or other padding all around and tie it securely.

2) Carefully print on the box or carton the following name and address

TIGER ELECTRONIC TOYS,
REPAIR CENTER
980 Woodlands Parkway,
Vernon Hills, Illinois 60061, USA.

Also, don't forget to show your return address.

3) Put parcel post stamps on the package; insure the package, then mail.

After the 90-day warranty period and up to one year from the date of purchase, do all of the above PLUS enclose your check or money order for US\$12.00 payment for the repair service.

M.C. HAMMER™ Used Under License from © Bustin Productions, Inc.

© 1991 TIGER ELECTRONICS, INC.
980 Woodlands Parkway, Vernon Hills,
Illinois 60061, U.S.A.

PRINTED IN HONG KONG