

# MINNIE MOUSE CYCLE

## ASSEMBLY INSTRUCTIONS

Ages 1-3  
Weight Limit 40 lbs.

Model No. 50504  
P/N 40247000

**PLEASE NOTE:** ADULT ASSEMBLY REQUIRED. READ INSTRUCTIONS PRIOR TO ASSEMBLY.

**TOOLS REQUIRED (NOT INCLUDED):** Hammer, regular screwdriver, Phillips screwdriver and a small block of wood (approx. 2" x 2" x 3/4").

### WARNING:

ADULT SUPERVISION AND INSTRUCTION REQUIRED REGARDING THE PROPER USE OF THIS TOY. THIS RIDE-ON TOY SHOULD NOT BE USED NEAR SWIMMING POOLS, ON OR NEAR HILLS, ROADWAYS, SLOPED DRIVEWAYS, ALLEYS OR STEPS. SHOES MUST BE WORN AT ALL TIMES. ONLY ONE RIDER AT A TIME. DO NOT RIDE AFTER DARK. DO NOT CARRY ANYTHING THAT IMPAIRS VISION. CAUTION: DO NOT LEAVE CHILD UNATTENDED.

PLEASE RETAIN THIS GUIDE AND ALL LITERATURE FOR FUTURE REFERENCE

### STEP 1. FRONT WHEEL PEDAL ASSEMBLY

#### NOTE:

BEFORE you start assembly, check all parts carefully. See parts diagram on page 4.

**NOTE: FOR EASY ASSEMBLY, TRIM ALL PLASTIC PARTS OF EXCESS MATERIAL.**

Slide a spacer washer onto the PEDAL CRANK-SHAFT up to the wheel center. Next, slide a PEDAL onto the PEDAL CRANK-SHAFT (rounded corners on pedal away from the wheel.) Then, slide a PALNUT COVER onto the PEDAL CRANK-SHAFT (flat side facing pedal) and finally, fit a PALNUT over protruding end of shaft, as shown.

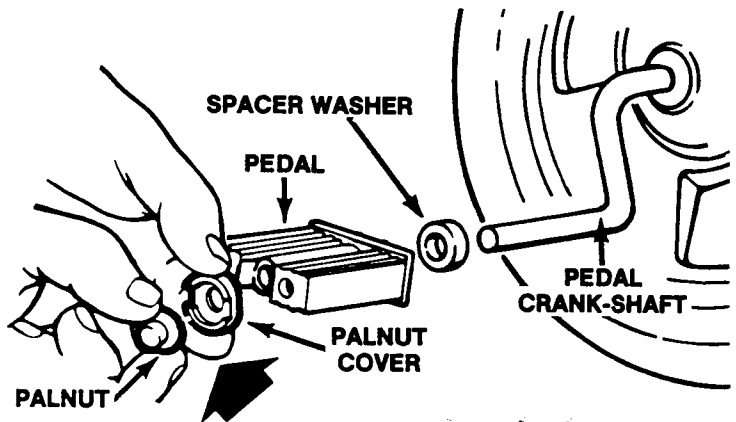

### STEP 2. FASTENING OF PEDAL TO PEDAL CRANK-SHAFT

Use the edge of a flat surface to support the wheel PEDAL ASSEMBLY (see illustration). Then, position the PALNUT TOOL over the PALNUT and strike the end of the tool with the hammer. Make sure the PALNUT is engaged by pulling on the PEDAL. Repeat STEPS 1 and 2 for the opposite side of the front wheel.

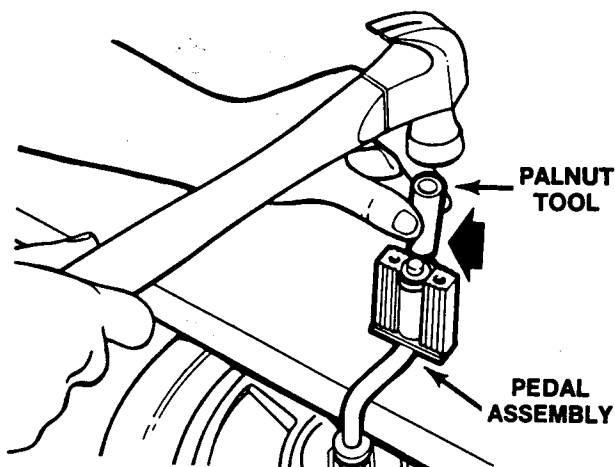

### STEP 3. JOIN FRONT FORK TO WHEEL ASSEMBLY

Fit the FORK under CRANK-SHAFT as shown. Make certain that spacer washers are between the wheel and fork.

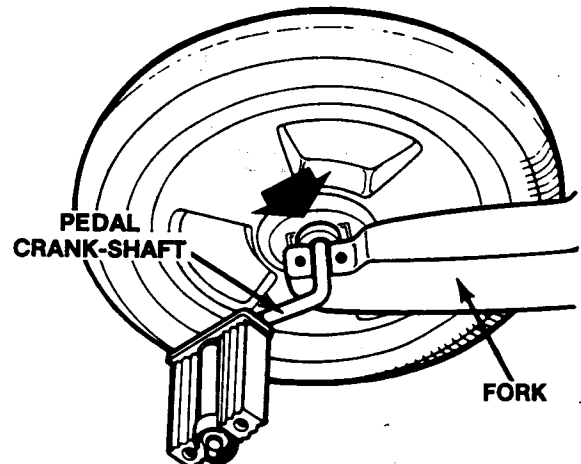

#### BE SAFE

- DO NOT RIDE MINNIE MOUSE CYCLE AFTER DARK.
- DO NOT CARRY ANYTHING THAT WILL IMPAIR VISION.
- DO NOT RIDE DOUBLE ON YOUR MINNIE MOUSE CYCLE.

#### STEP 4. ASSEMBLE FRONT WHEEL TO FORK

Position the AXLE CAP over the pedal crank (see illustration). Next, using the Phillips screwdriver, tap and drive a 1" LENGTH SCREW into the hole closest to the top of the fork. Do the same with a 5/8" LENGTH SCREW in the remaining hole. Repeat this step for the other side of the fork.

**NOTE: DO NOT USE EXCESSIVE FORCE WHEN DRIVING THE SCREW INTO THE FRONT FORK. DO NOT OVERTIGHTEN.**

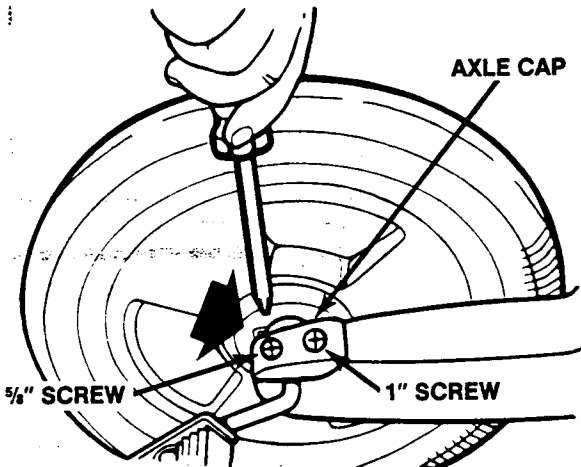

#### STEP 5. ATTACHING REAR WHEELS TO BODY ASSEMBLY

Place the rear axle onto a small BLOCK OF WOOD, as shown. Secure a PALNUT to one end of AXLE using the PALNUT tool. With the three spokes facing out, slide axle through one wheel. Then, slide a CLICKER onto the AXLE in the position shown. Push the assembly through the left side of the body.

Slide the remaining CLICKER onto axle as shown. Put other rear wheel (with 3 spokes out) onto the rear axle.

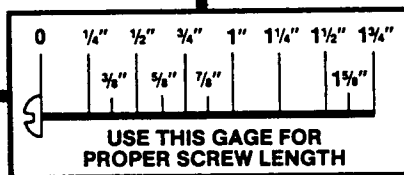
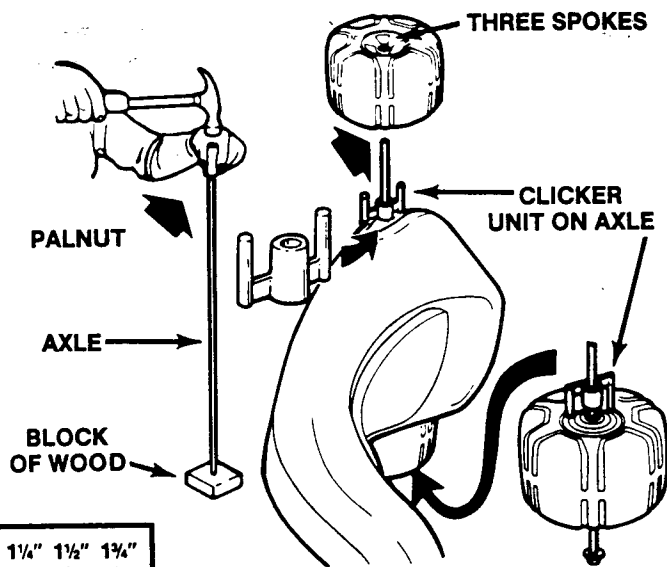

#### STEP 6. FASTENING REAR WHEELS TO BODY ASSEMBLY

Put a PALNUT on the end of the rear axle. Using the PALNUT TOOL and hammer, fasten the PALNUT as shown. This will fasten the wheels to the body assembly. Make sure BLOCK OF WOOD is positioned as shown.

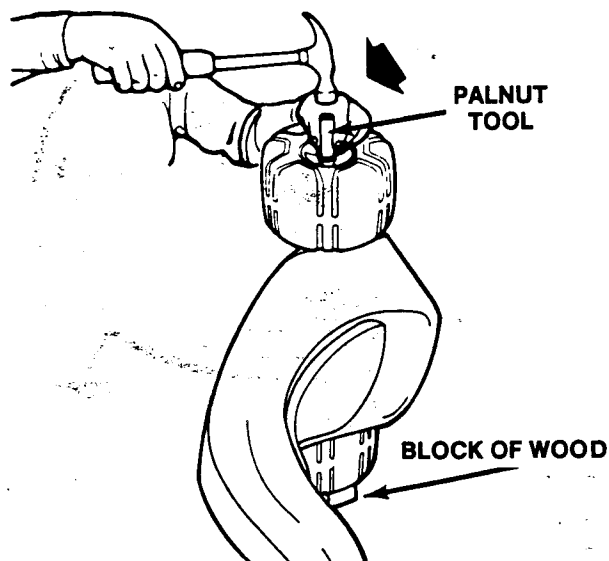

#### STEP 7. ATTACH FRONT FORK AND HANDLEBAR

Insert the FRONT FORK through body. The AXLE CAPS must face the back of the cycle. Then, slide the handlebar onto the fork post, handles facing back. Handlebar must be fully seated to fork.

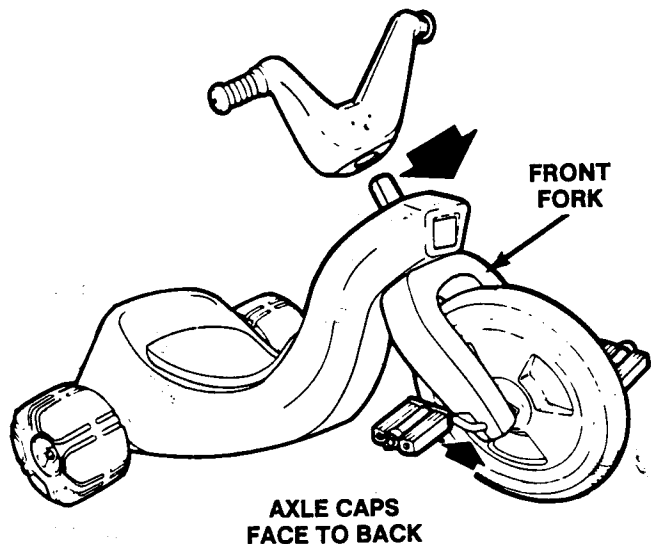

### STEP 8. FASTEN HANDLEBAR

Insert two (2) 1½" SCREWS into pilot holes on each side of the handlebar until screws are engaged. Then turn cycle upside down on its HANDLEBAR. Push down on fork and screw the screws tightly into handlebar assembly.

**BE CAREFUL NOT TO OVERTIGHTEN.**

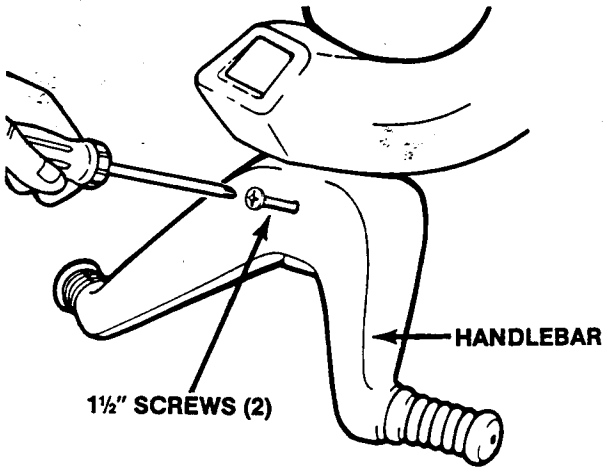

### STEP 9. ASSEMBLE PLAQUE

Align the two screw holes in PLAQUE BACK with handlebar holes. Fasten with two (2) ¾" SCREWS. DO NOT OVERTIGHTEN. Position FACE PLAQUE onto back, align holes and attach with two (2) ½" BLUNT SCREWS, as shown. DO NOT OVERTIGHTEN.

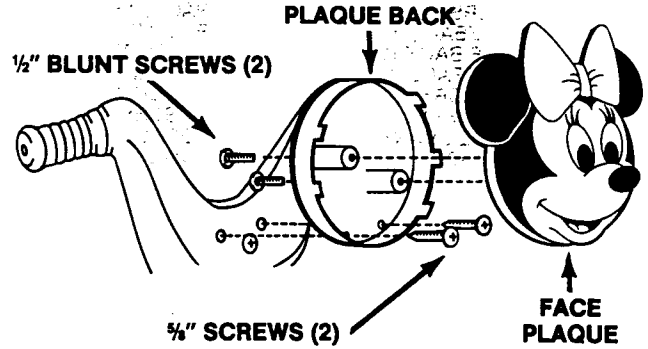

#### IMPORTANT NOTICE

PARENTS: PLEASE MAKE PERIODIC INSPECTIONS OF ALL HARDWARE TO ENSURE THAT IT IS SECURE.

### STEP 10. DECAL INSTRUCTIONS

**NOTE: THOROUGHLY WIPE DECAL AREAS WITH CLEAN DRY CLOTH BEFORE APPLYING DECALS.**

Using decal sheet, remove decals one at a time and apply to appropriate positions on Minnie Mouse Cycle, as shown on diagram. Make sure all decals are positioned on cycle as shown.

#### IMPORTANT

DECALS HAVE QUICK SETTING ADHESIVE, BE SURE OF POSITION BEFORE APPLYING—DECAL CANNOT BE LIFTED AFTER SETTING.

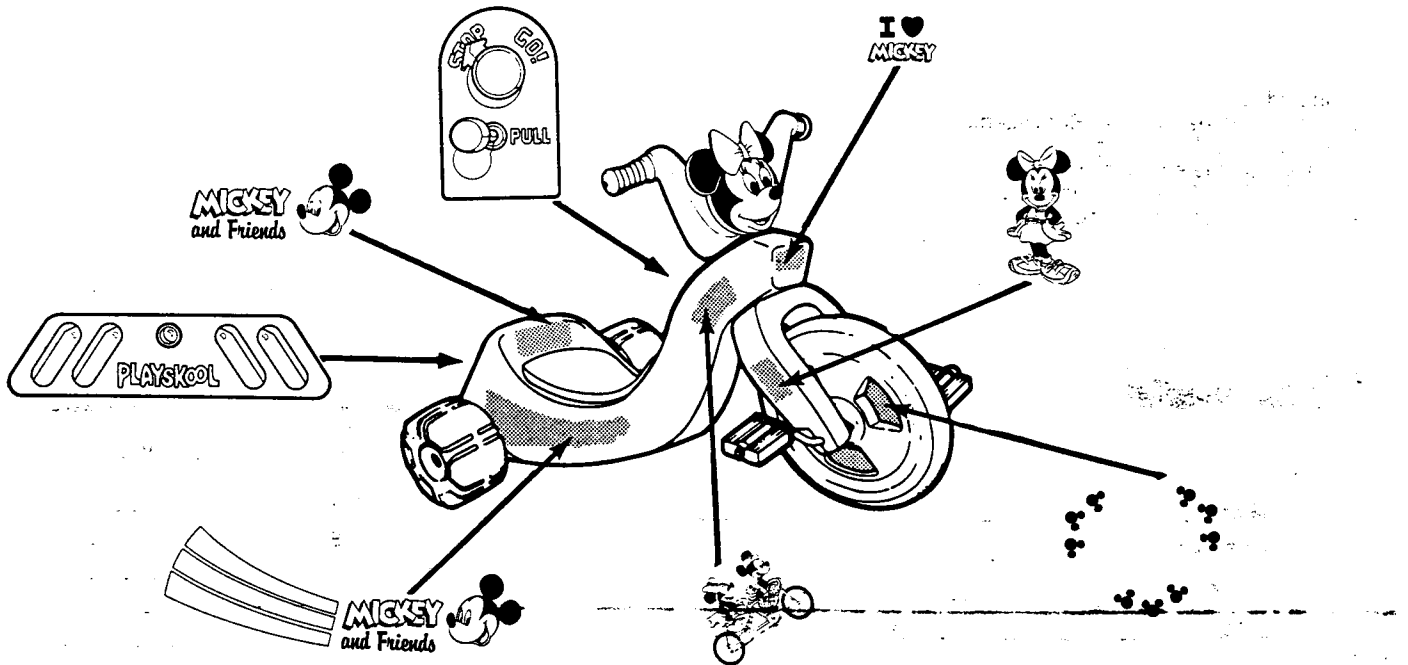

**PLEASE NOTE:** If you have any questions or comments concerning this product, call our Playskool Customer Service hotline 1-800-237-0063 Monday through Friday, 8:30 am to 4:30 pm. Eastern Standard Time. In Rhode Island, call: 431-8697

All written inquiries should be mailed to: Playskool Consumer Services Division  
P.O. Box 5839, Pawtucket, Rhode Island 02862

This will provide quick and reliable service for your product. Do not request same from your dealer.

# REPLACEMENT PARTS ORDER FORM

## PARTS DIAGRAM

Please check all parts carefully before assembly.

### KEY NO.

- |                    |                       |
|--------------------|-----------------------|
| 1. BODY            | 11. FRONT SPACER      |
| 2. REAR WHEELS (2) | WASHERS (2)           |
| 3. REAR AXLE (1)   | 12. AXLE CAPS (2)     |
| 4. CLICKERS (2)    | 13. PALNUT COVERS (2) |
| 5. HANDLEBAR (1)   | 14. PALNUTS (4)       |
| 6. PLAQUE BACK (1) | 15. PALNUT TOOL (1)   |
| 7. PLAQUE FACE (1) | 16. 1½" SCREWS (2)    |
| 8. FRONT FORK (1)  | 17. 1" SCREWS (2)     |
| 9. FRONT WHEEL     | 18. ¾" SCREWS (4)     |
| W/PEDAL CRANK (1)  | 19. ½" SCREWS (2)     |
| 10. PEDALS (2)     | 20. DECAL SHEET       |
|                    | (Not shown)           |

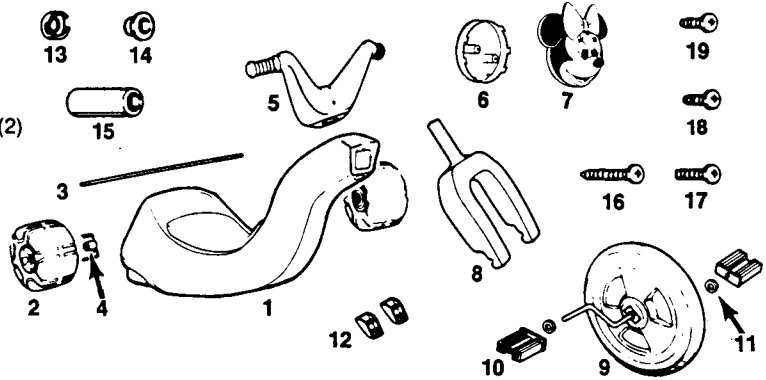

REPLACEMENT PARTS LISTED BELOW ARE THE ONLY ONES AVAILABLE

KEY NUMBER	DESCRIPTION	PART NO.	QUANTITY	PRICES	TOTAL
1	BODY: (Not available as a replacement part)				
2	REAR WHEEL: (1 each)	40285202		\$1.50	
3	REAR AXLE: (1 each)	40285100		.70	
5	HANDLEBAR: (1 each)	40285402		1.65	
6,7,18,19	PLAQUE KIT: (1 each Plaque Back, 1 each Plaque Face, 2 each ¾" screws, 2 each ½" screws)	405102		1.55	
8,16	FRONT FORK KIT: (1 each Front Fork, 2 each 1½" screws)	40285302		1.25	
9,11,12,15	FRONT WHEEL W/CRANK: (1 each Front Wheel w/Crank 2 each Axle Caps, 2 Palnuts and Tool)	405103		3.80	
12	AXLE CAP KIT: (Universal Replacement)	405104		1.00	
20	DECORATIVE KIT: (1 each Decal Sheet)	405105		1.30	
10,11,13,14,15	PEDAL KIT: (2 each Pedals, 2 each Palnut Covers, 2 each Spacer Washers, 2 Palnuts and Tool)	405106		2.10	
16,17,18,19	HARDWARE BAG: (Includes correct amount of each Key Number listed)	40287300		1.80	
4,13,14,15	PALNUT BAG: (Includes correct amount of each Key Number listed)	405107		1.50	
				<b>MERCHANDISE TOTAL</b>	
				<b>APPROPRIATE STATE TAX</b>	
				<b>HANDLING AND SHIPPING</b>	3.50
				<b>TOTAL</b>	

### HOW TO ORDER PARTS

- Fill out shipping label below. Print clearly, in ink, as label will be applied to the outside of your package. U.S. residents be sure to include ZIP code.
- Extend prices, NY, PA, RI residents add applicable sales tax, plus shipping and handling.
- Send completed form with check or money order only (DO NOT MAIL CASH OR COINS) to address below.
- No C.O.D. orders will be accepted.
- We reserved the right to substitute when necessary.

**NOTE: Prices and parts subject to change without prior notice.**

SHIPPING LABEL — PRINT CLEARLY IN INK, DO NOT REMOVE.



Send to: Playskool, Inc.  
P.O. Box 5839  
Pawtucket, RI 02862

TO:

NAME \_\_\_\_\_

STREET \_\_\_\_\_

CITY \_\_\_\_\_

STATE \_\_\_\_\_ ZIP CODE \_\_\_\_\_

**POSTMASTER:** CONTENTS MERCHANDISE — RETURN POSTAGE GUARANTEED. MAY BE OPENED FOR POSTAL INSPECTION IF NECESSARY.

## MINNIE MOUSE CYCLE

Model No. 50504

P/N 40247000

FOR OFFICE USE ONLY	
DATE RECD. _____	
AMT. RECD. _____	
RECD. BY _____	
DATE SHIPPED _____	
VIA _____	
NOTES _____	