

Musical Ice Cream Cart™



5074

Thank you for purchasing this Playskool® toy!

Adult assembly and Phillips screwdriver required. Requires 2 "AA" batteries (not included).

Includes cart, 2 ice cream cones, 2 scoops of ice cream, 2 ice pops, 2 coins, and instructions.

Adults: Remove pieces from plastic bags and discard bags immediately.

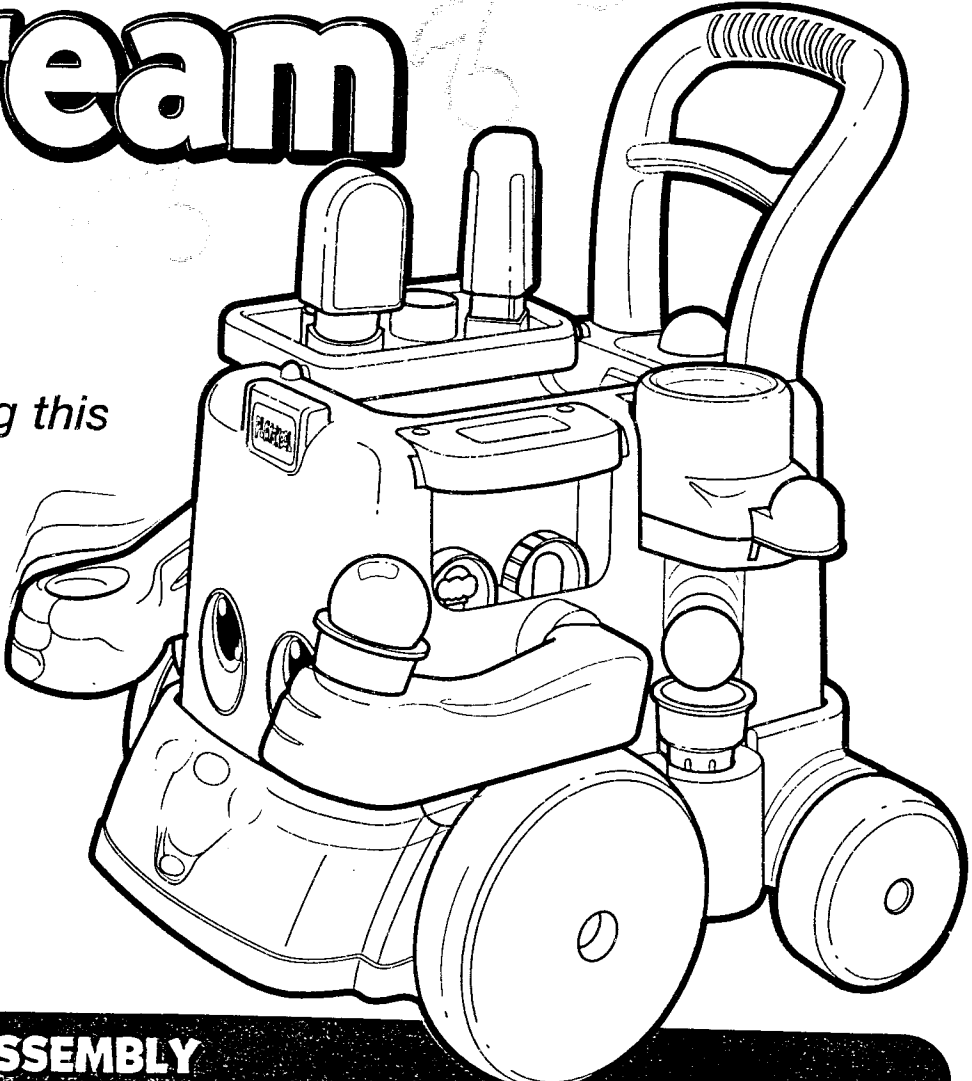

BODY AND CHASSIS ASSEMBLY

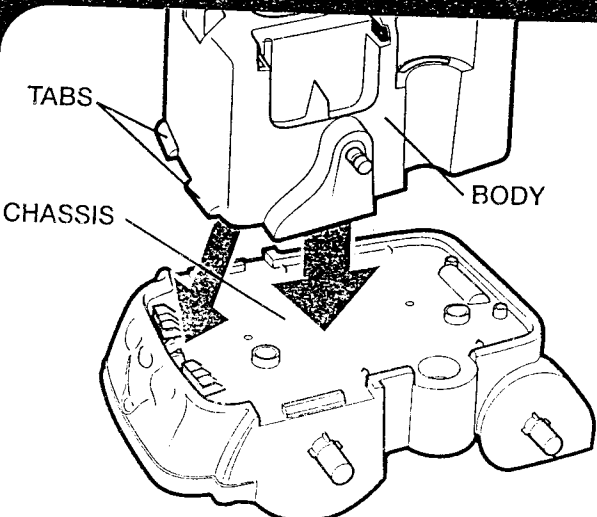

1. Insert tabs on body into front of chassis, and lower body onto chassis. Important: Press against the inside of the body (where the tabs are) to make sure the tabs are completely inserted into the chassis.

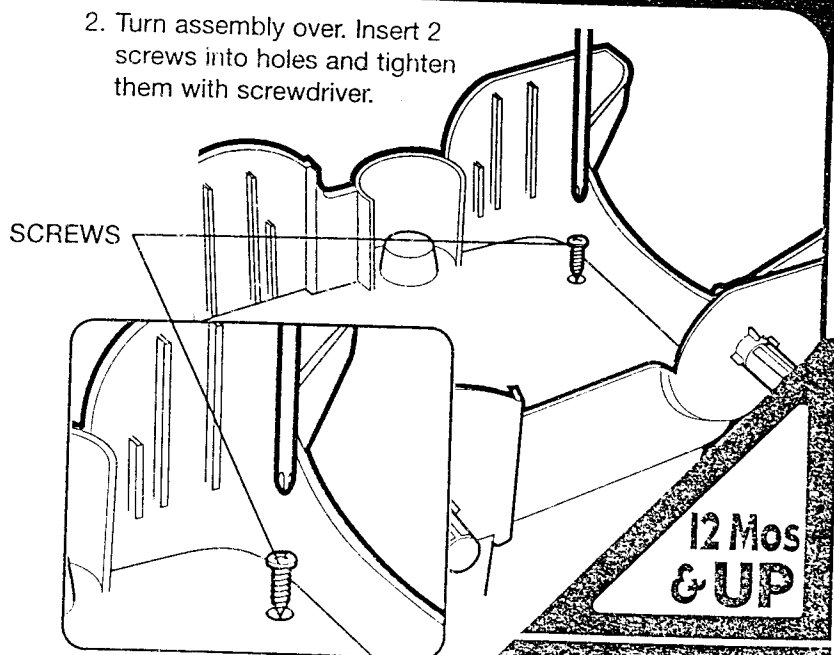

2. Turn assembly over. Insert 2 screws into holes and tighten them with screwdriver.

12 Mos & UP

TODDLER

ELECTRONIC MODULE

1. Slide electronic module down into slot in rear of cart. Attach module to cart using 2 screws and a screwdriver.

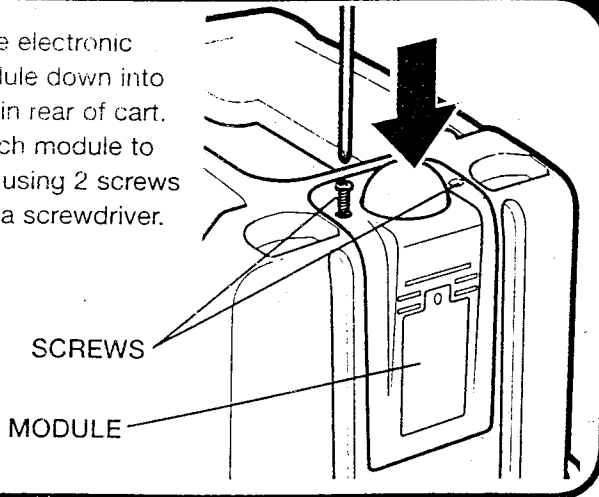

SERVER ASSEMBLY

1. Turn lever and server top upside down. Place lever on server top (make sure tab does not hang over the inside edge of the server top).
2. Holding server bottom right side up, place it on upside down lever/server top. Attach server assembly together using 2 screws and a screwdriver.

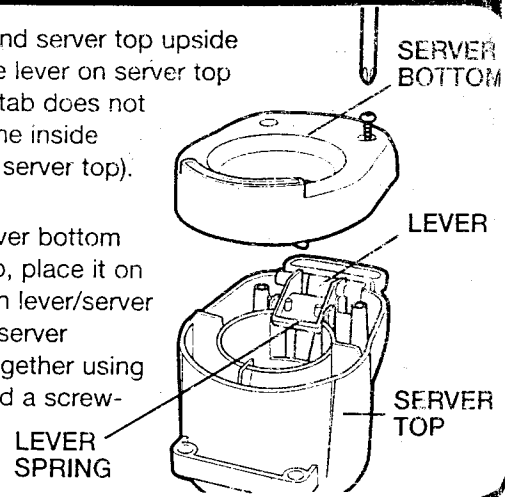

SERVER ASSEMBLY cont.

3. Slide server assembly down into side of cart. Attach server to cart using 2 screws and a screwdriver.

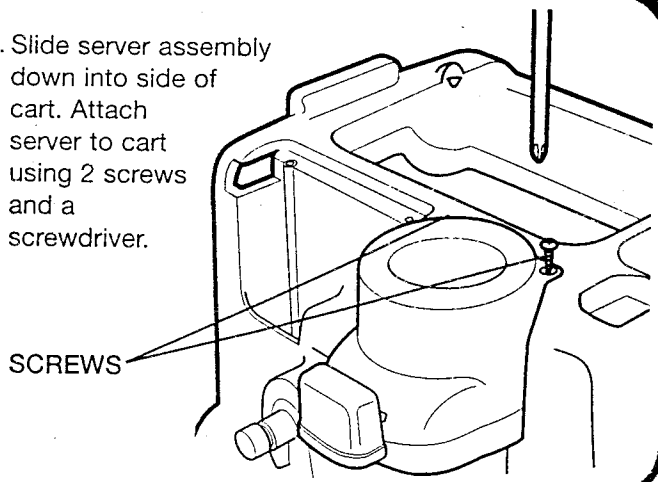

COIN COVER

- Slide coin cover into side of cart. Attach cover to cart using 2 screws and a screwdriver.

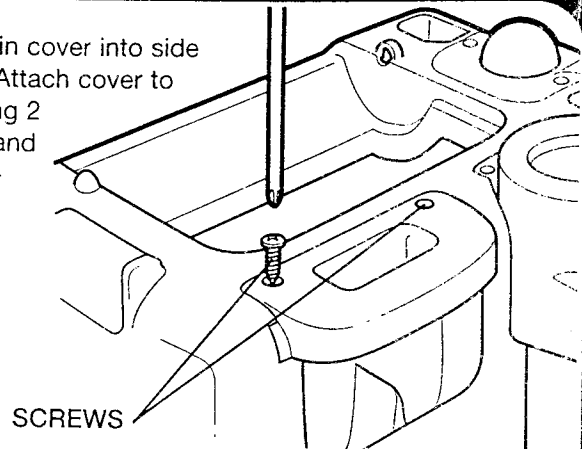

SHAPE-SORTER TRAY

To attach tray correctly, make sure that the Playskool logo will face up when the tray covers the storage area. Insert long post on tray into hole. Snap small post into remaining hole.

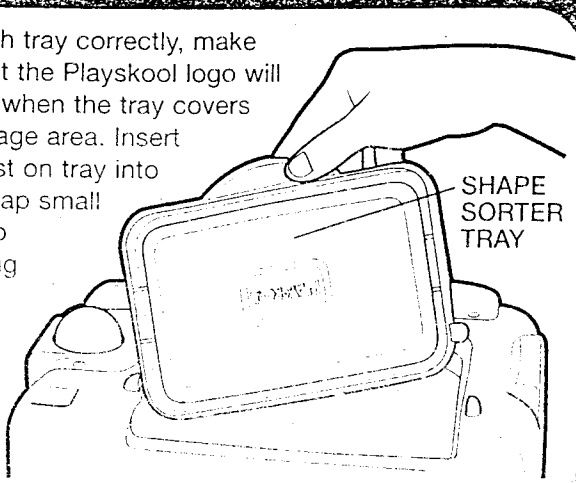

HANDLE

HANDLE

Place cart on floor. Insert ends of handle into holes until handle snaps into place.

Important: Pull up on each side of handle near the cross-bar to make sure handle is completely snapped into place. It is important to attach handle correctly the first time because it cannot be attached correctly later.

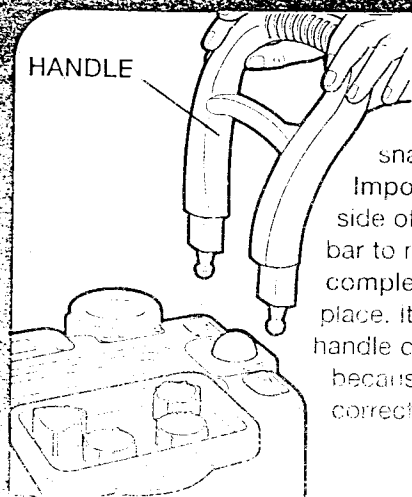

WHEELS

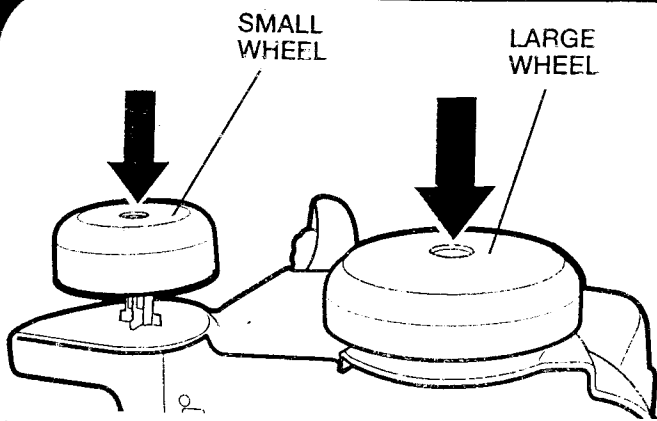

Lay cart on its side. Snap large wheels onto front wheel posts. Snap small wheels onto back wheel posts. Note: You have to press down very firmly when attaching the wheels. It helps to place your hand under the wheel attachment area and push up as you press down on the wheel.

ARMS

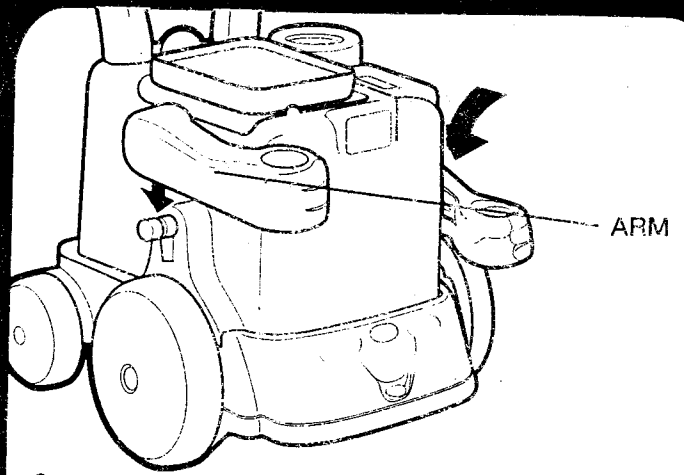

Snap arms onto posts on sides of cart. Make sure arms extend forward, as shown in illustration. (The arms are designed to pop off when meeting any resistance, such as if the cart runs into a wall. They easily re-attach to the posts.)

LABELS

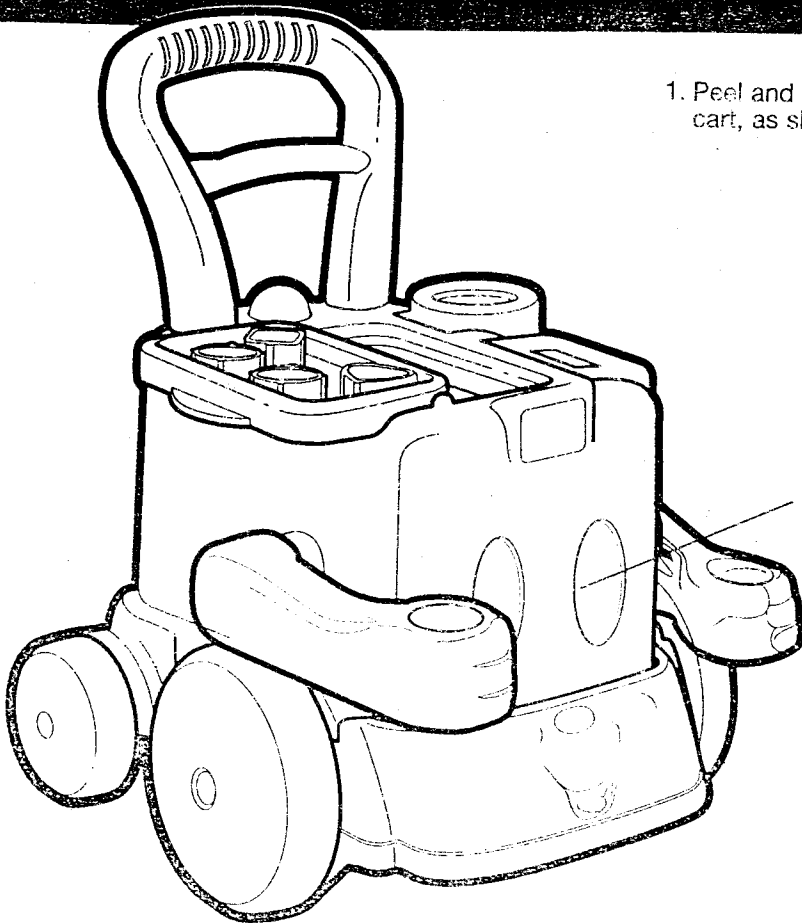

1. Peel and apply eye labels into recessed areas on front of cart, as shown.

INSERT BATTERIES

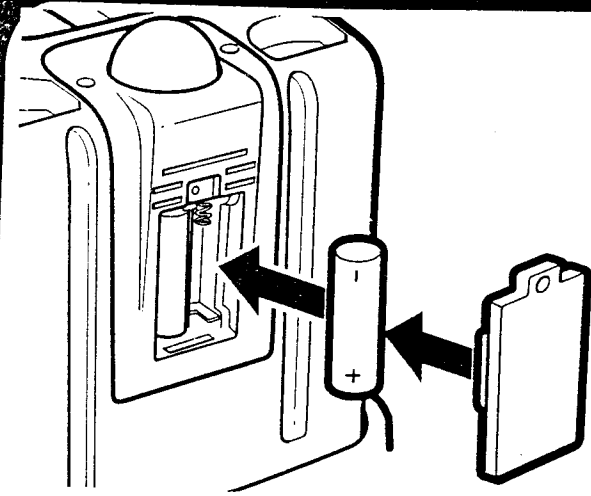

1. Loosen screw in battery door on electronic module (screw will remain attached to door). Remove door, and insert 2 new "AA" batteries (not included). Replace door and tighten screw with screwdriver.

CAUTION: TO AVOID BATTERY LEAKAGE

1. Be sure to insert the batteries correctly and always follow the toy and battery manufacturers' instructions.
2. Do not mix old batteries and new batteries.
3. Do not mix alkaline, standard (carbon zinc) or rechargeable (nickel-cadmium) batteries.
4. Always remove exhausted or dead batteries from the product.

FCC STATEMENT:

This equipment has been tested and found to comply with the limits for a Class B digital device, pursuant to part 15 of the FCC Rules. These limits are designed to provide reasonable protection against harmful interference in a residential installation. This equipment generates, uses and can radiate radio frequency energy, and, if not installed and used in accordance with the instructions, may cause harmful interference to radio communications. However, there is no guarantee that interference will not occur in a particular installation. If this equipment does cause harmful interference to radio or television reception, which can be determined by turning the equipment off and on, the user is encouraged to try to correct the interference by one or more of the following measures:

- Reorient or relocate the receiving antenna.
- Increase the separation between the equipment and the receiver.
- Consult the dealer or an experienced radio/TV technician for help.

Changes or modifications not expressly approved by the party responsible for compliance could void the user's authority to operate the equipment.

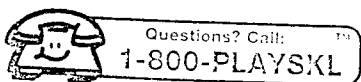

Questions? Call: 1-800-PLAYSKL

Product and colors may vary.
© 1998 Hasbro, Inc.
® denotes Reg. U.S. Pat. & TM Office
U.S. Patent Pending
P/N 47852300