

Get the Nak  
to Stack™



The Stacking Battle™ action figure



The WAVE ROCKER™ Stacking Platform rocks as you stack!  
Balance your NAKNAK™ figures in stationary mode,  
or pull out and twist the square knob for rocking action!



Press button to start 10-second countdown,  
then stack before time runs out.  
Timer re-starts automatically  
for next stack or next player's turn!

## 3 ways to play!

### Individual Play

Build and balance NAKNAK figures on the WAVE ROCKER platform.  
How many NAKNAK figures can you stack?

### Competition Play

Compete with your friends in stacking competitions.  
If your NAKNAK figure knocks down the stack, you lose that figure!

### Competition with Dice Play

Use the dice from the NAKNAK 5-PACK (sold separately) and follow the Rules included in your NakNak booklet for champion level stacking!

Includes  
Special Holographic  
NAKNAK™ Figure!  
Other figures sold separately, not included.

Special HOLOGRAPHIC  
NAKNAK figure  
can be used as  
a "wild" in NAKNAK Challenges!  
[See Booklet for  
Holographic NakNak Figure  
Bonus Play.]

Cool electronic  
countdown sounds!



Get the Nak  
to Stack™

AGES 5+

72145



The Stacking Battle™ action figure

Requires 3 "AA" alkaline batteries (not included).  
Phillips screwdriver needed to insert batteries.



#### TO REPLACE BATTERIES

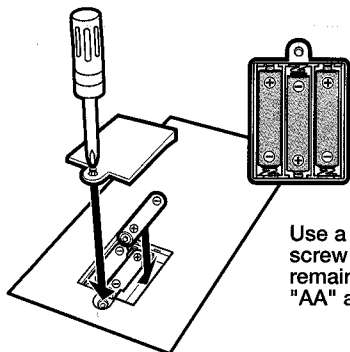

Use a crosshead/Phillips screwdriver (not included) to loosen screw in battery compartment door. Remove door (screw remains attached to door) and discard batteries. Insert 3 "AA" alkaline batteries. Replace door and tighten screw.



#### CAUTION: TO AVOID BATTERY LEAKAGE

1. Be sure to insert the batteries correctly and always follow the toy and battery manufacturers' instructions;
2. Do not mix old and new batteries or alkaline, standard (carbon-zinc) or rechargeable (nickel-cadmium) batteries;
3. Always remove weak or dead batteries from the product.

#### FCC STATEMENT:

This device complies with part 15 of the FCC Rules. Operation is subject to the following two conditions: (1) This device may not cause harmful interference, and (2) this device must accept any interference received, including any interference that may cause undesired operation. This equipment has been tested and found to comply with the limits for a Class B digital device, pursuant to part 15 of the FCC Rules. These limits are designed to provide reasonable protection against harmful interference in a residential installation. This equipment generates, uses and can radiate radio frequency energy, and, if not installed and used in accordance with the instructions, may cause harmful interference to radio communications. However, there is no guarantee that interference will not occur in a particular installation. If this equipment does cause harmful interference to radio or television reception, which can be determined by turning the equipment off and on, the user is encouraged to try to correct the interference by one or more of the following measures:

- Reorient or relocate the receiving antenna.
- Increase the separation between the equipment and receiver.
- Consult the dealer or an experienced radio/TV technician for help.



© & © Hasbro. All Rights Reserved. © denotes Reg. U.S. Pat. & TM Office.  
U.S. patent pending.

P/N 6191560000