

50575



Ages 3-6
Weight Limit: 70 lbs.

WARNING: Contains small parts which pose a choke hazard for children under the age of three.



16" Power Cycle
BUILT TOUGH TO LAST!

PLEASE KEEP THIS GUIDE AND ALL LITERATURE FOR FUTURE REFERENCE

Important Note: This product should be assembled by an adult. Periodically check all hardware to be sure it is secure. Please read instructions prior to assembly. Study each step carefully to familiarize yourself with procedure and parts. Refer to back page for illustrated parts list. For easier assembly, trim excess plastic from all parts before starting.

TOOLS REQUIRED (NOT INCLUDED): Hammer, Phillips® screwdriver and a small block of wood.

CAUTION: ADULT SUPERVISION AND INSTRUCTION REQUIRED REGARDING THE PROPER USE OF THIS TOY. THIS RIDE-ON TOY SHOULD NOT BE USED NEAR SWIMMING POOLS, ON OR NEAR HILLS, ROADWAYS, SLOPED DRIVEWAYS, ALLEYS OR STEPS. SHOES MUST BE WORN AT ALL TIMES. ONLY ONE RIDER AT A TIME. DO NOT RIDE AFTER DARK. DO NOT CARRY ANYTHING, PARTICULARLY OBJECTS THAT IMPAIR VISION, WHILE RIDING THIS TOY. DO NOT LEAVE CHILD UNATTENDED WHILE RIDING THIS TOY.

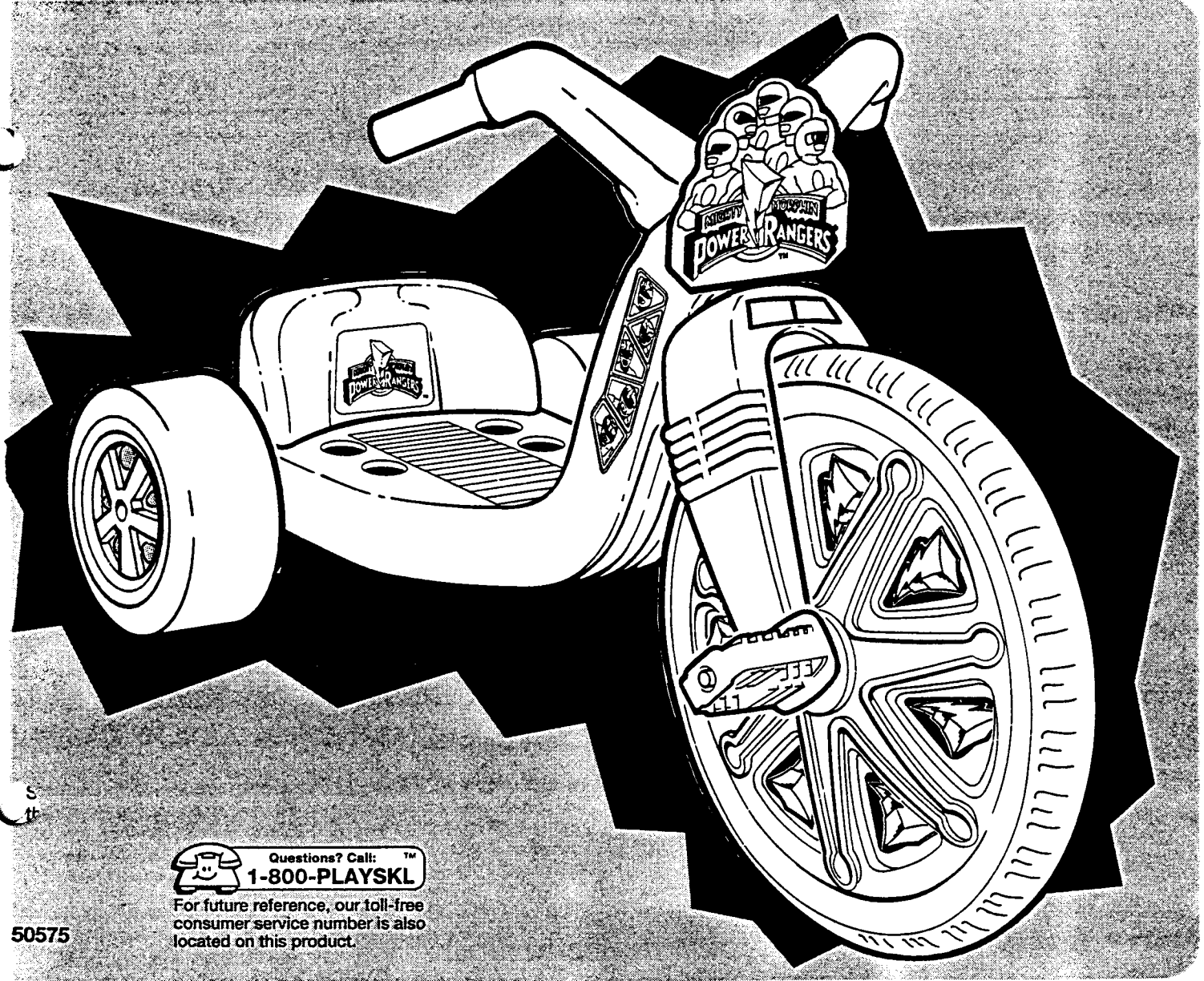

Questions? Call: 1-800-PLAYSKL

For future reference, our toll-free consumer service number is also located on this product.

50575

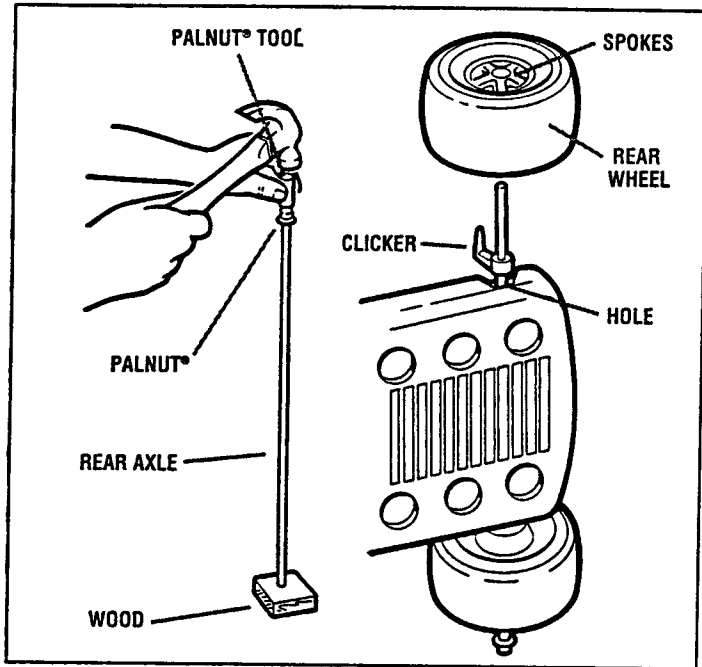

STEP 1. REAR WHEEL ASSEMBLY

1A) Place rear axle on small block of wood as shown. Position Palnut over top end of axle. Fit Palnut tool over Palnut. Using hammer, hit Palnut onto end of axle.

1B) Slide axle through hole in spoked side of rear wheel. Slide axle through hole in rear of body.

1C) Slide clicker onto axle and into body as shown. Slide other rear wheel over end of axle, so that spokes on wheel face out.

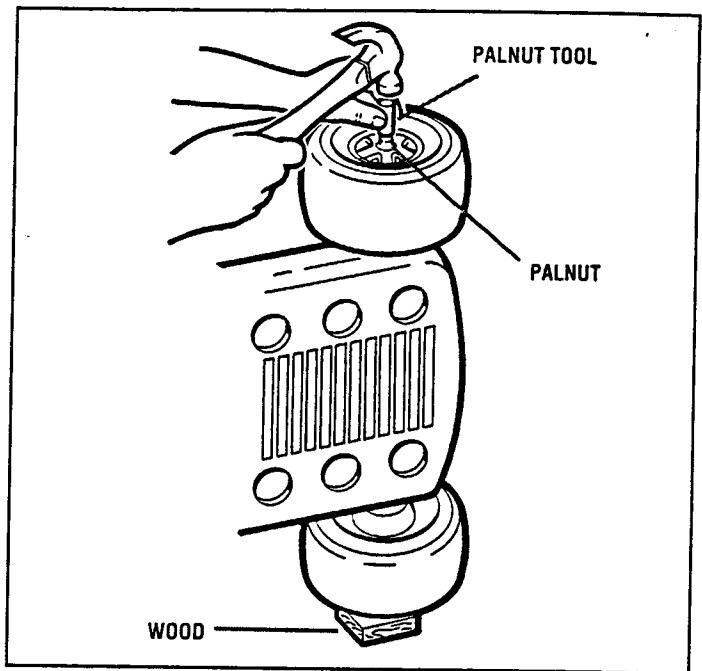

STEP 2. REAR WHEEL/BODY ASSEMBLY

Stand body on its side, with open end of axle pointing up. Place block of wood under other end of axle.

If necessary, press down on top wheel so that open end of axle sticks through wheel. Position Palnut over open end of axle, and fit Palnut tool over Palnut. Using hammer, hit Palnut onto end of axle.

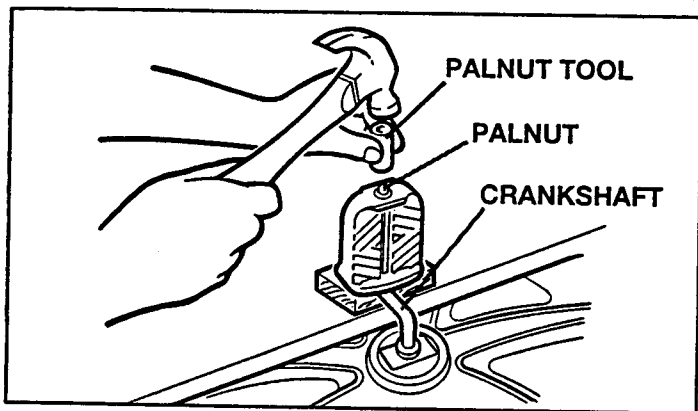
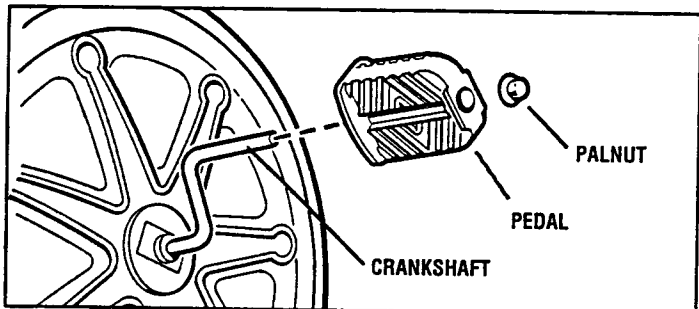

STEP 3. FRONT PEDAL ASSEMBLY

Slide pedal over end of pedal crankshaft. NOTE: The flat end of the pedal should be facing in as shown. Fit Palnut over end of crankshaft. Place block of wood under other end of crankshaft for support as shown. Fit Palnut tool over Palnut. Using hammer, hit Palnut onto end of axle. Repeat steps with other side.

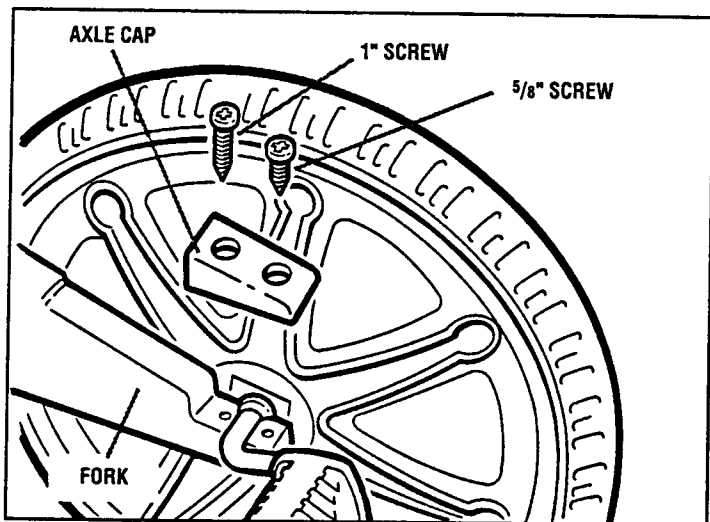
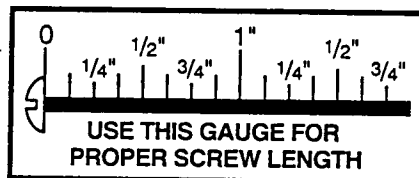

STEP 4. FORK & WHEEL ASSEMBLY

Fit front wheel axle into grooves in front fork. Place axle cap over one end of axle as shown. Line up holes in axle cap with holes in fork. Fit 1" screw into top hole in axle cap and tighten, using Phillips screwdriver. Fit 5/8" screw into bottom hole in axle cap and tighten, using Phillips screwdriver. DO NOT OVERTIGHTEN SCREWS. Repeat steps with other side.

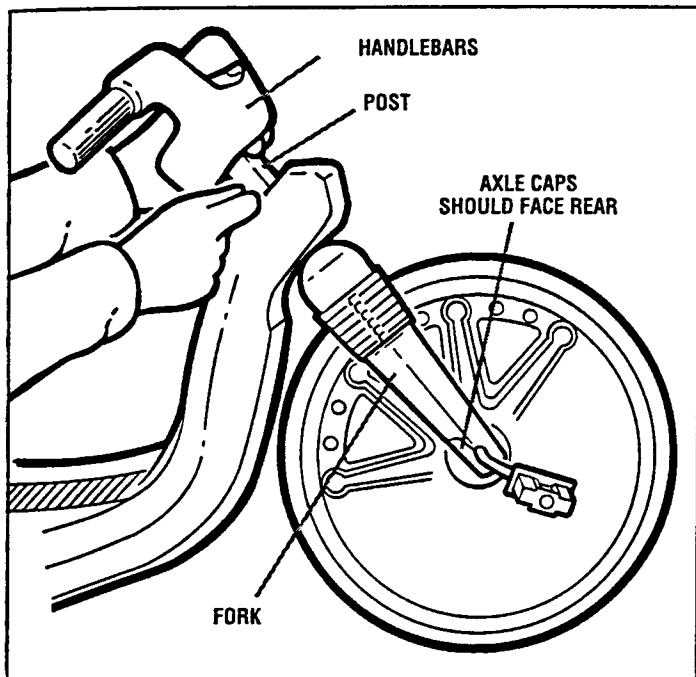

STEP 5. HANDLEBARS ASSEMBLY

Insert post on fork through hole in front of body. Slide handlebars over post on fork. **IMPORTANT NOTE:** Axle caps and handlebar handles should be facing the rear of the cycle.

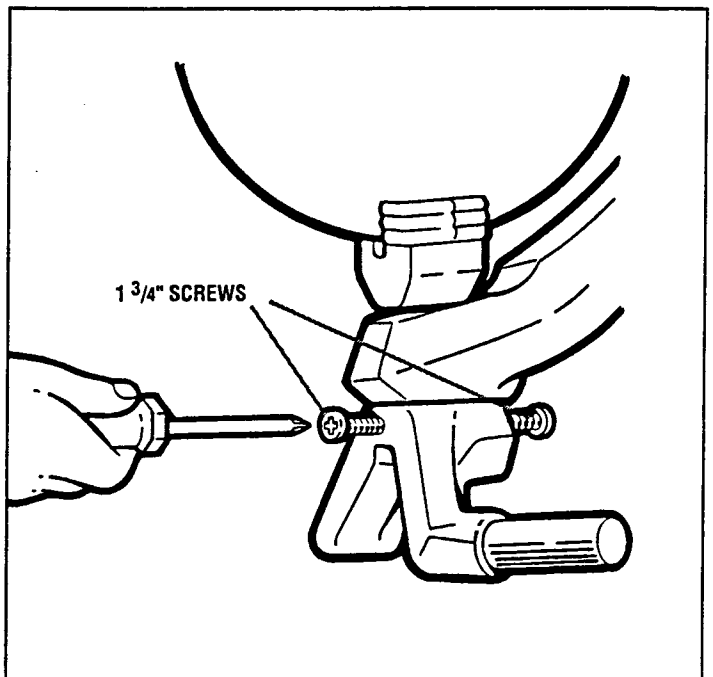

STEP 6. HANDLEBARS ASSEMBLY (CONT.)

Turn cycle upside down. Push down on fork and fit two 1 3/4" screws into holes in handlebars. Tighten screws, using Phillips screwdriver. **DO NOT OVERTIGHTEN SCREWS.**

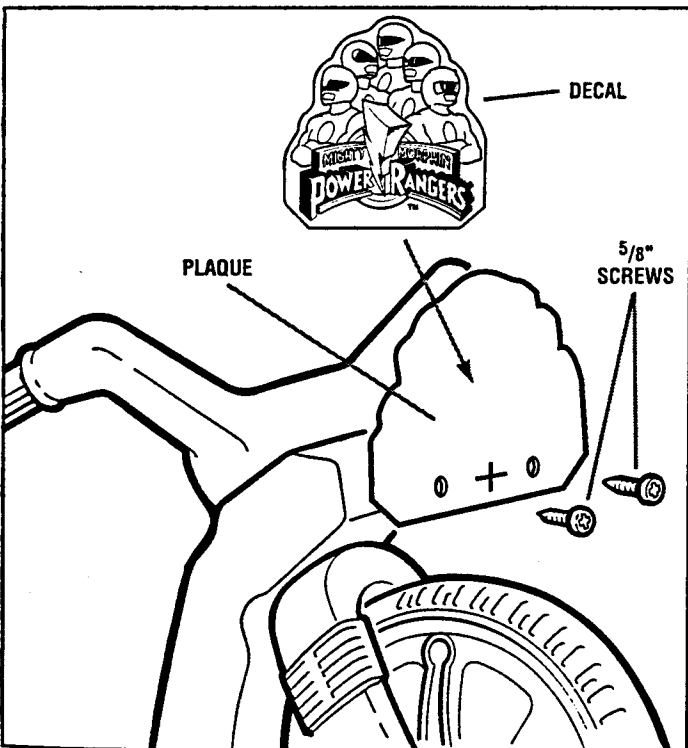

STEP 7. PLAQUE ASSEMBLY

Wipe plaque with clean, dry cloth. Make sure holes are at bottom of plaque and the side marked "+" is facing out as shown. Remove decal from decal sheet and apply to plaque as shown. Line up holes in plaque with holes in body. Fit two 5/8" screws through decal and plaque, and into holes in body. Tighten screws using Phillips screwdriver. **DO NOT OVERTIGHTEN SCREWS.**

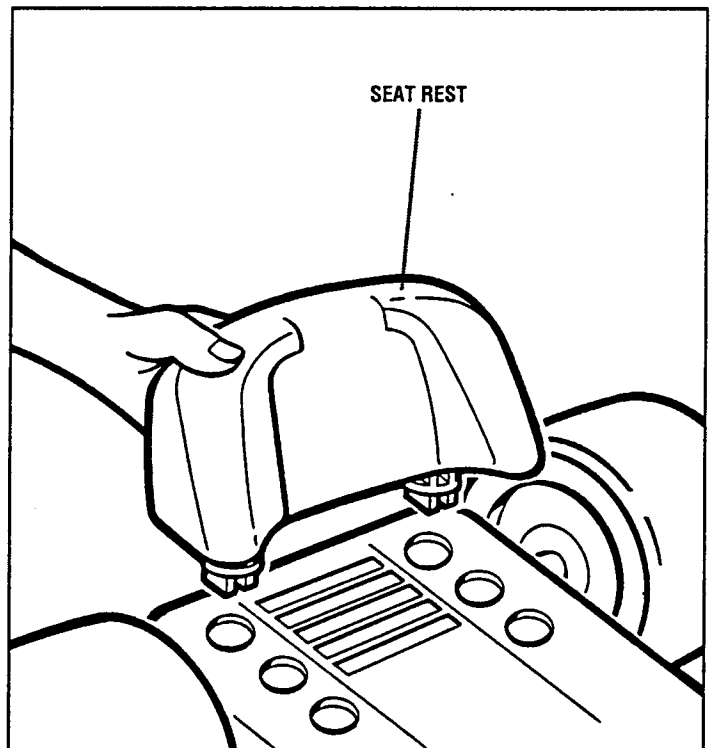

STEP 8. SEAT ASSEMBLY

Insert posts on seat rest into holes in body as shown. **NOTE:** You can adjust the seat to 3 different positions. Be sure your child's feet rest firmly on the pedals when riding this toy.

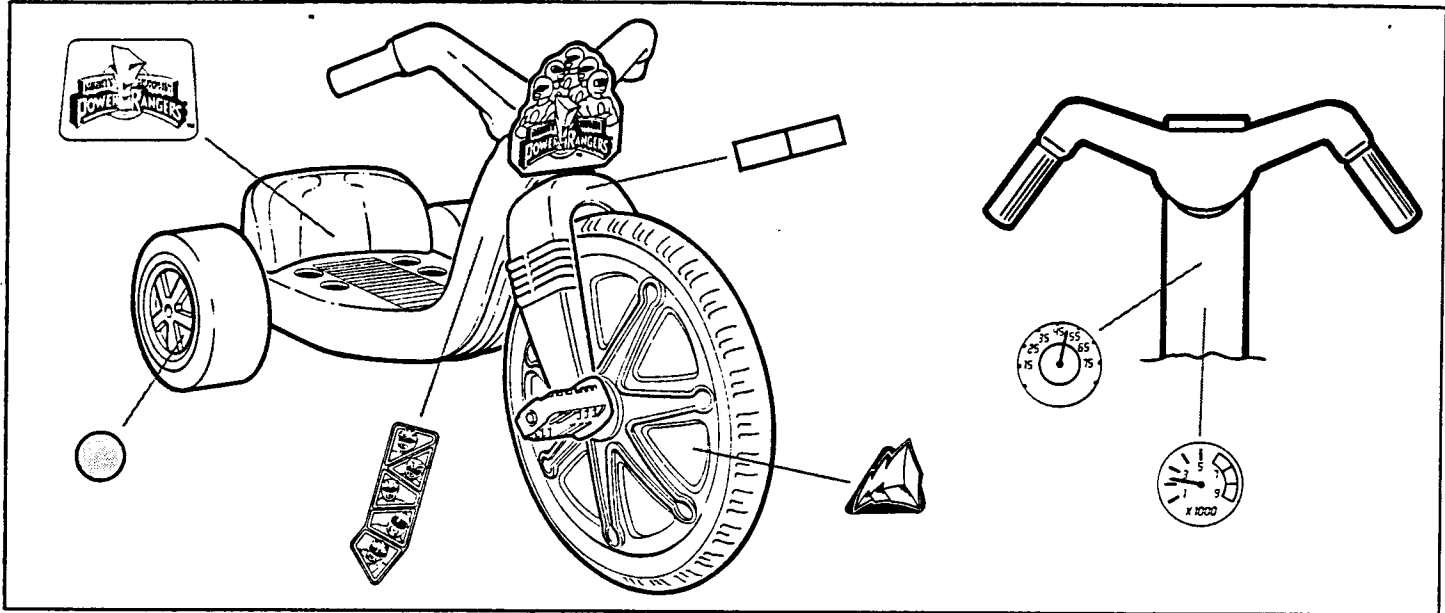

STEP 9. DECAL APPLICATION

Thoroughly wipe decal areas clean with dry cloth before applying decals. Peel decals from decal sheet one at a time and apply as shown. For best results, be sure all decals are positioned on cycle exactly as shown.

IMPORTANT: BE SURE OF DECAL PLACEMENT BEFORE ALLOWING DECALS TO SET OVERNIGHT.

Replacement Parts Order Form Parts Diagram for Mighty Morphin Power Rangers™ Power Cycle® Ride-on Model 50575

Please check all parts carefully before assembly.

- | | |
|--------------------|-----------------------------|
| 1. BODY | 10. AXLE CAPS (2) |
| 2. REAR WHEELS (2) | 11. 1 3/4" SCREWS (2) |
| 3. SEAT REST | 12. 1" SCREWS (2) |
| 4. REAR AXLE | 13. 5/8" SCREWS (4) |
| 5. HANDLEBARS | 14. PALNUTS (5) |
| 6. PLAQUE | 15. PALNUT TOOL |
| 7. FRONT FORK | 16. CLICKER |
| 8. FRONT WHEEL | 17. DECAL SHEET (Not shown) |
| 9. PEDALS (2) | |

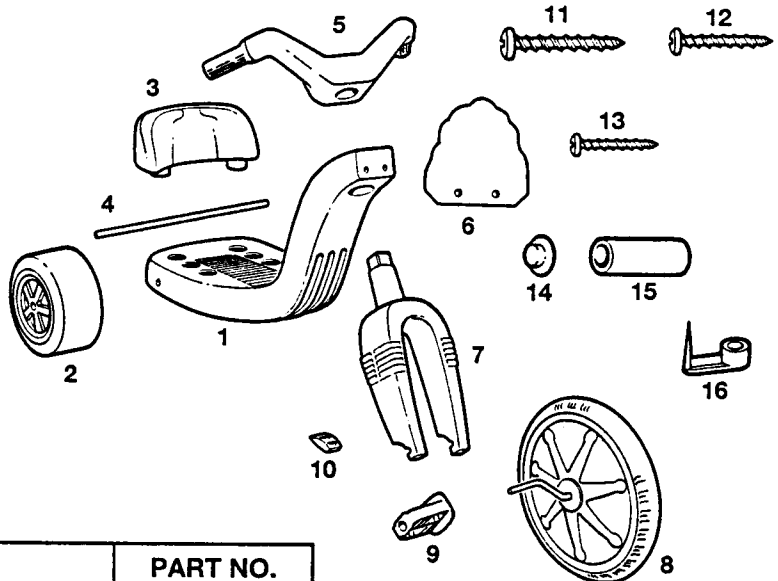

ITEM NO.	DESCRIPTION	PART NO.
1	BODY	44061604
2	1 REAR WHEEL	40282911
3	1 SEAT REST	40282614
4	1 REAR AXLE	40282802
5	1 SET OF HANDLEBARS	43633011
6	PLAQUE	45492500
7	1 SET OF FRONT FORKS	40282717
8	FRONT WHEEL WITH CRANKSHAFT	40284808
9	PEDAL KIT - 2 PEDALS, 2 PALNUTS® & PALNUT TOOL	KIT 93003
10	AXLE CAP KIT	KIT 1006
11, 12, 13	HARDWARE BAG - (2) 1 3/4" SCREWS, (2) 1" SCREWS, (4) 5/8" SCREWS	44234700
14, 15, 16	PALNUT BAG - 5 PALNUTS, PALNUT TOOL, CLICKER	KIT 381
17	DECAL SHEET	45492601

If you have any questions, comments, or need additional information concerning this product or its parts, please call our Playskool Consumer Service hotline at 1-800-PLAYSKL (1-800-752-9755), Monday through Friday, 8:00 AM to 5:00 PM Eastern Time.

All written inquiries should be mailed to: Playskool Consumer Service Department P.O. Box 200, Pawtucket, Rhode Island 02862-0200

Palnut® is a registered trademark of TRW, Inc. All Rights Reserved.

©1994 Playskool, Inc., Pawtucket, RI 02862 U.S.A., a subsidiary of Hasbro, Inc. All Rights Reserved.

™ and ©1994 Saban Entertainment, Inc. & Saban International N.V. All Rights Reserved. MIGHTY MORPHIN POWER RANGERS and all logos, character names and distinctive likenesses thereof are trademarks of Saban Entertainment, Inc., and Saban International N.V.

® denotes Reg. U.S. Pat. & TM Office. MADE AND PRINTED IN U.S.A.

50575 P/N 45493801