

# POWER SPARK

ACCESSORY SET

ACTION VEHICLE



# INSTRUCTIONS

Ages 8 & Up

Thank you for purchasing this unique, high quality product from Kenner. For maximum enjoyment, please be sure to read and follow these instructions carefully.

If you have any questions, comments, or need additional information concerning this product or its parts, please call our Kenner Consumer Service hotline at 1-800-327-8264, Monday through Friday, 8:00 AM to 5:00 PM Eastern Time.

Designed for use with the Power Spark Welding Set. **WELDING GUN NOT INCLUDED.**

**INCLUDES:** Vehicle chassis and assembly parts, 24 welding rods, 2 flints, 15 weld-on accessories and label sheet.

## 1 Applying the Labels:

Peel and apply labels to the unassembled parts as desired. (Labels numbered 1 and 2 are sized to fit on the hubcaps; label on the bottom of the sheet is sized to fit on the vehicle dashboard.)

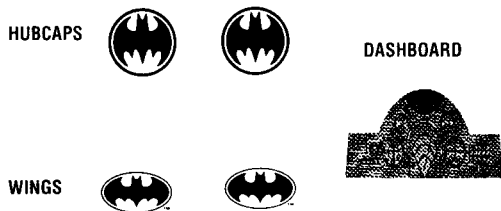

## Unassembled Parts:

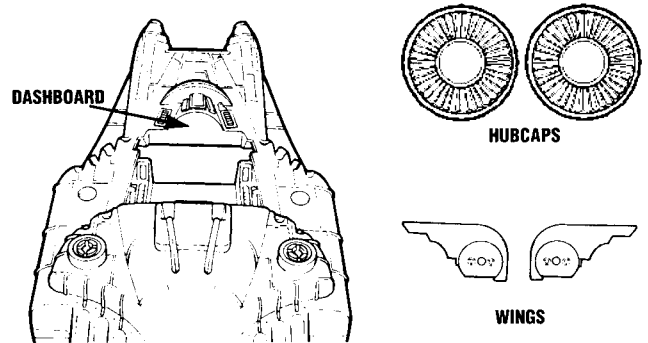

## 2 Assembly: Note: Large snap-on wings cannot be welded.

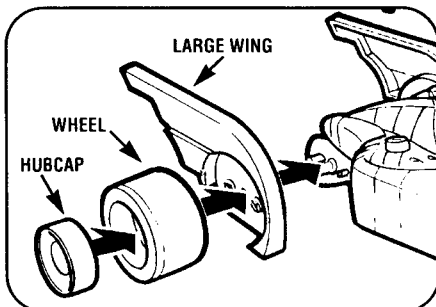

Snap large wings onto sides of vehicle. Place wheels onto shafts and press firmly until each snaps into place. Snap hubcaps into wheels.

**ONE-TIME ASSEMBLY**  
Once assembled cannot be taken apart!

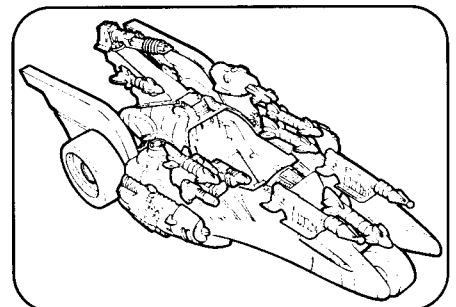

Snap missile launcher into place as shown. **CAUTION: DO NOT AIM WEAPON AT EYES OR FACE.**

### 3 Flint Placement:

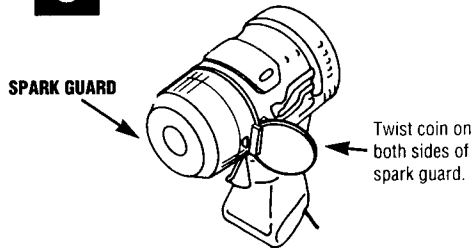

Flints should be replaced when the welding gun no longer sparks. To replace flints, put edge of coin into position shown and twist so that spark guard slides up - first one side, then the other, until flint holes on spark guard are exposed.  
**Do not remove spark guard.**

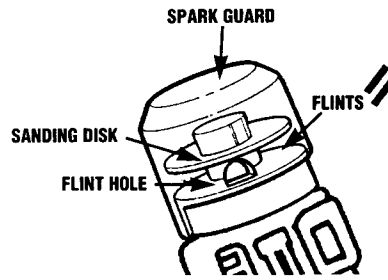

Hold welding gun as shown with spark guard pointing upward. Drop 2 flints into one of the flint holes on either side of the spark guard. **Flints should be between the sanding disk and the front of the welding gun.**

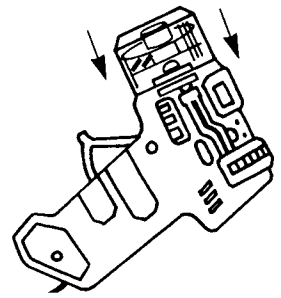

Push spark guard closed.  
**IMPORTANT: Welding gun will not operate unless spark guard is fully closed.** Flints are standard lighter flints. **Do not** use more than two flints in welding gun.

### 4 Welding:

Insert welding rod **firmly** and pull trigger to make rod spin. Hold accessory piece securely on chassis while welding. Tilt welding gun as shown.

Place spinning welding rod on location you want to weld. Once welding rod begins to melt, move it slowly until you get the desired weld. *(To avoid breaking welding rod, do not press too hard.)* With practice, you will become more skilled at welding. Keep in mind that it may take several tries before you get the knack.

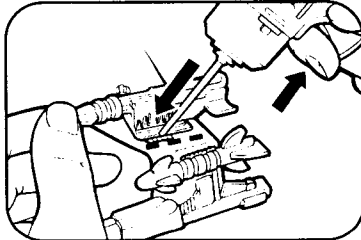
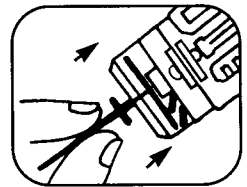

#### WELDING METHODS:

##### SPOT WELDING (RECOMMENDED)

WELD SMALL BEADS TO BOND THE ACCESSORY PIECE TO THE CHASSIS.

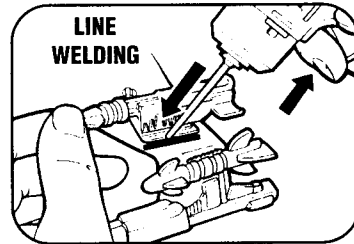

##### LINE WELDING

This method gives you the best smash-up play because pieces can be removed and rewelded with greater ease. Also, you will use fewer welding rods, thus allowing more parts to be welded.

**FOR A MORE PERMANENT ATTACHMENT, WELD A SOLID LINE TO BOND THE ACCESSORY PIECE TO THE CHASSIS.**

### 5 Customized Vehicle Assembly:

Arrange accessory pieces on chassis as you like to design your own customized vehicle. For different looks, pieces can be removed and rewelded.

**Note:** When welding or rewelding pieces of chassis, **Do not** try to scrape off excess or leftover welding material.

To purchase additional welding rods, see the enclosed order form or call our Consumer Service hotline at 1-800-327-8264, Monday through Friday, 8:00 AM to 5:00 PM Eastern Time.

ILLUSTRATION (A)

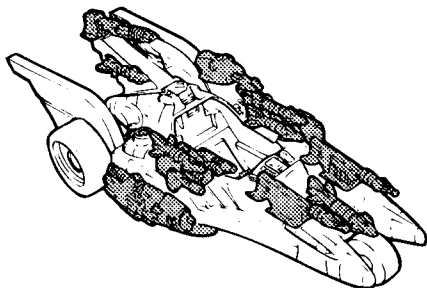

ILLUSTRATION (B)

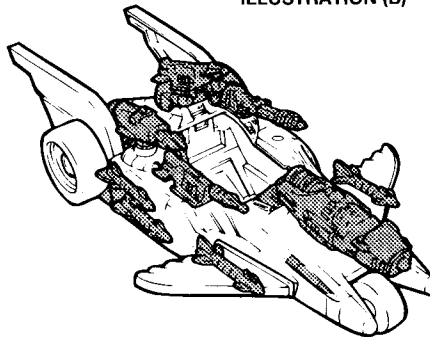
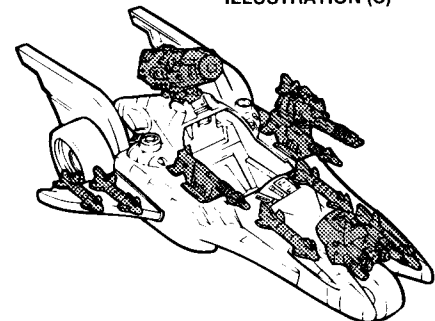

ILLUSTRATION (C)



BATMAN and all related elements are the property of DC Comics.™ & © 1995. All Rights Reserved.

\* © & ©1995 Tonka Corporation, a subsidiary of Hasbro, Inc., Pawtucket, Rhode Island 02862. Power Spark™ is a trademark of Tonka Corporation. All Rights Reserved.

©denotes Reg. U.S. Pat. & TM Office.

U.S. Patent Pending **MADE IN CHINA.**

66033/66035 Asst. P/N 51909500

**Weld'em, Crash'em  
Then Build'em Again!**

**Kenner** \*