

To Replace Batteries

Using a Phillips/crosshead screwdriver (not included), loosen screw in battery compartment cover. Remove cover. Remove and discard batteries. Insert 3 x 1.5v "AAA" or R03 batteries. Alkaline batteries recommended. Replace door, and tighten screw with screwdriver. See diagrams for polarity.

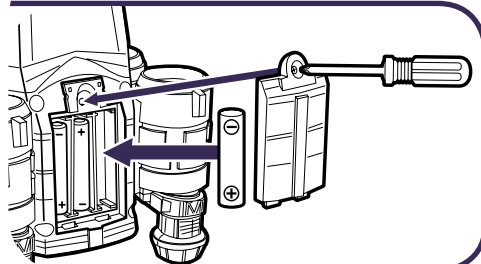

CAUTION:

- 1) As with all small batteries, the batteries used with this toy should be kept away from small children who still put things in their mouths. If they are swallowed, promptly see a doctor and, in the U.S., have the doctor phone (202) 625-3333 collect. In Canada, have the doctor call your provincial Poison Control Center.
- 2) Make sure the batteries are inserted correctly and follow the toy and battery manufacturers' instructions.
- 3) Do not mix old and new batteries, alkaline, standard (carbon-zinc) or rechargeable (nickel-cadmium) batteries.

IMPORTANT: BATTERY INFORMATION

Please retain this information for future reference.

Batteries should be replaced by an adult.



CAUTION:

1. Always follow the instructions carefully. Use only batteries specified and be sure to insert them correctly by matching the + and - polarity markings.
2. Do not mix old batteries and new batteries, or standard (carbon-zinc) with alkaline batteries.
3. Remove exhausted or dead batteries from the product.
4. Remove batteries if product is not to be played with for a long time.
5. Do not short-circuit the supply terminals.
6. Should this product cause, or be affected by, local electrical interference, move it away from other electrical equipment. Reset (switching off and back on again or removing and re-inserting batteries) if necessary.
7. RECHARGEABLE BATTERIES: Do not mix these with any other types of battery. Always remove from the product before recharging. Recharge batteries under adult supervision. DO NOT RECHARGE OTHER TYPES OF BATTERIES.
8. As with all small items, these batteries should be kept away from children. If swallowed, seek medical attention immediately.

FCC STATEMENT

This equipment has been tested and found to comply with the limits for a Class B digital device, pursuant to part 15 of the FCC Rules. These limits are designed to provide reasonable protection against harmful interference in a residential installation. This equipment generates, uses and can radiate radio frequency energy, and, if not installed and used in accordance with the instructions, may cause harmful interference to radio communications. However, there is no guarantee that interference will not occur in a particular installation. If this equipment does cause harmful interference to radio or television reception, which can be determined by turning the equipment off and on, the user is encouraged to try to correct the interference by one or more of the following measures:

- Reorient or relocate the receiving antenna.
- Increase the separation between the equipment and the receiver.
- Consult the dealer or an experienced radio/TV technician for help.



Some poses may require additional support. Product and colors may vary.
© 2004 Lucasfilm Ltd. & ® or TM where indicated. All rights reserved.
Used under authorization. ®* and/or TM* & © 2004 Hasbro. All Rights Reserved.
® denotes Reg. U.S. Pat. & TM Office.

P/N 6410980002



AGES 3-8
85239/85255 Asst.

Batteries included. Replace with 3 x 1.5v "AAA" or R03 batteries. Alkaline batteries recommended. Phillips/crosshead screwdriver (not included) required to replace batteries.

X-wing Fighter™

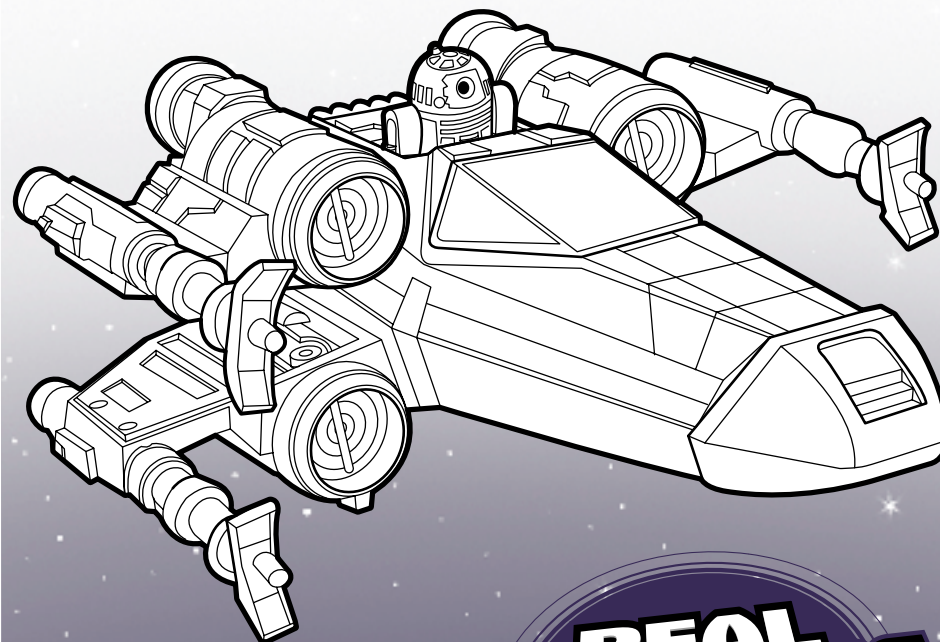

REAL
STAR WARS
SOUNDS



Luke Skywalker™

R2-D2™

Includes:
1 vehicle and 2 figures.

Luke Skywalker™

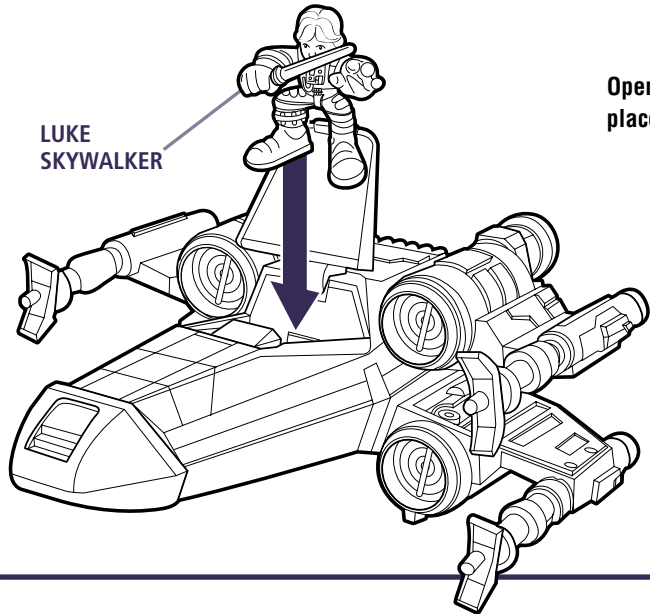

LUKE SKYWALKER

Open cockpit and place figure inside.

R2-D2™

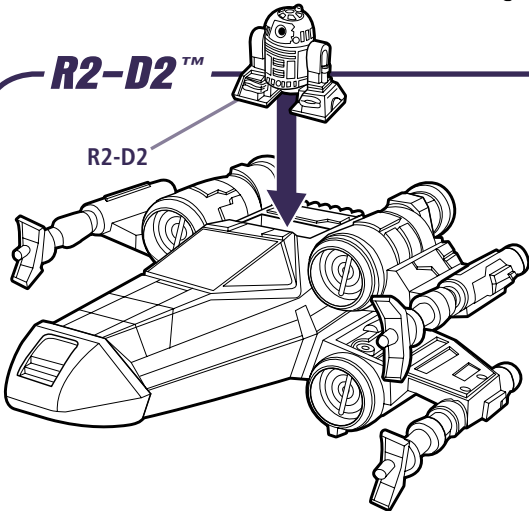

R2-D2

Place R2-D2 in droid socket. Press and release R2-D2 to hear a phrase. Keep pressing and releasing R2-D2 to hear the other phrases.

Press and hold R2-D2 to hear engine sounds. If you press cannon button or press R2-D2 again, weapon sounds/actions or firing sounds/explosion/music will be activated. If the button is pressed while the engine sound is still on, the engine sounds will continue after the other sounds have stopped. The engine sounds will continue to play after other sound sequences until vehicle is allowed to shut down automatically after a period of non-activity.

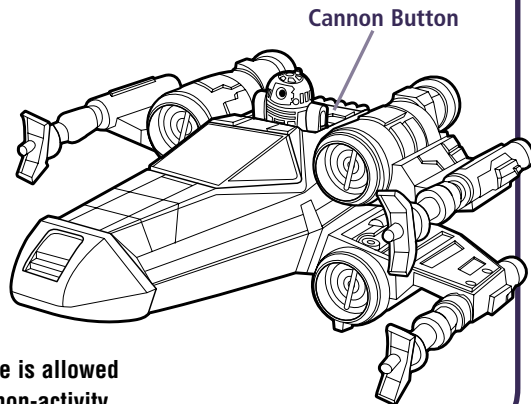

Cannon Button

Cannon Button

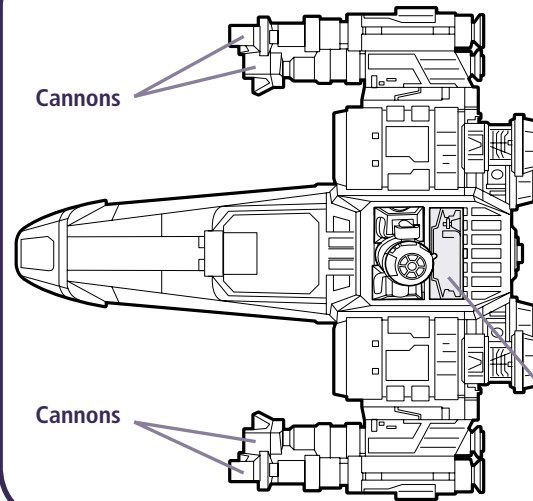

Cannons

Cannons

Press and release cannon button behind R2-D2 to hear blaster sounds and make cannons move in and out. Keep pressing and releasing the button to repeat sounds and action.

Press and hold button behind R2-D2 to hear firing torpedo sounds and a random phrase and explosion/music. Keep pressing and holding the button to repeat the sounds. The different sound sequences will alternate randomly.

Cannon Button

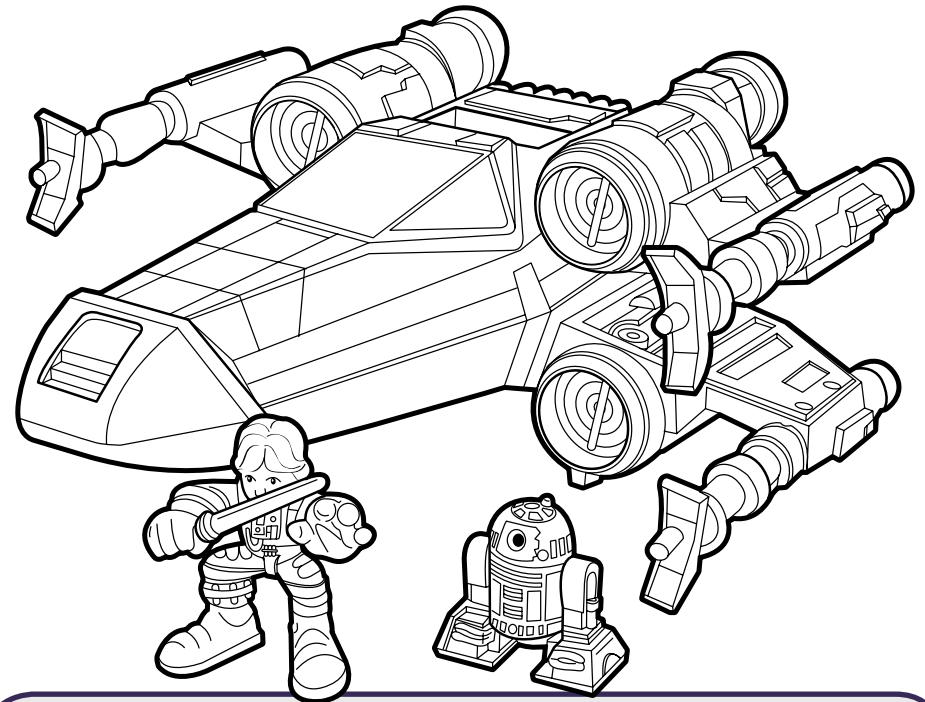

Phrases:

"Luke, the Force will be with you."

"Red Five standing by."

"Red Five. I'm going in."

"R2, that stabilizer's broken loose again. See if you can't lock it down."

[R2-D2 sounds]

"Luke. Trust your feelings."

"Use the Force, Luke."

"Remember, the Force will be with you always."

[Star Wars theme music]