

# STAR WARS

## Millennium Falcon™

AGES 4+  
85234

Requires 3 x 1.5V "AA" or R6 size batteries. Alkaline batteries recommended.  
Phillips/cross head screwdriver (not included) needed to insert batteries.

Some assembly required. No tools needed.

### LABELS

Apply labels as shown.

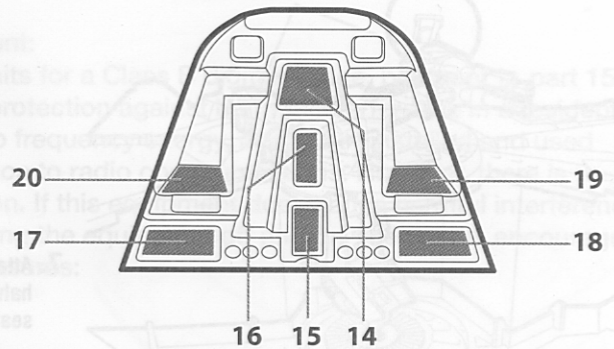
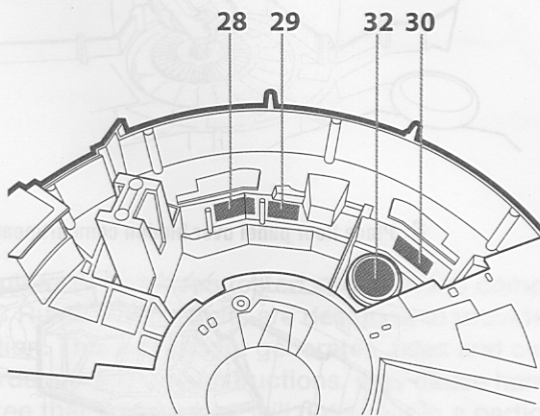
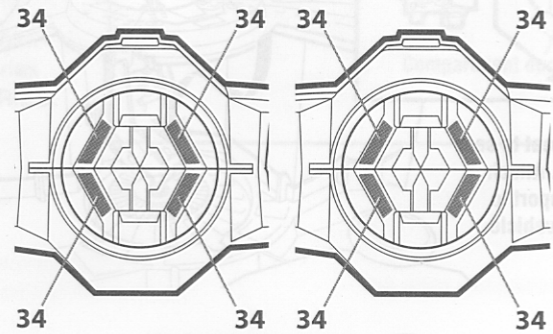
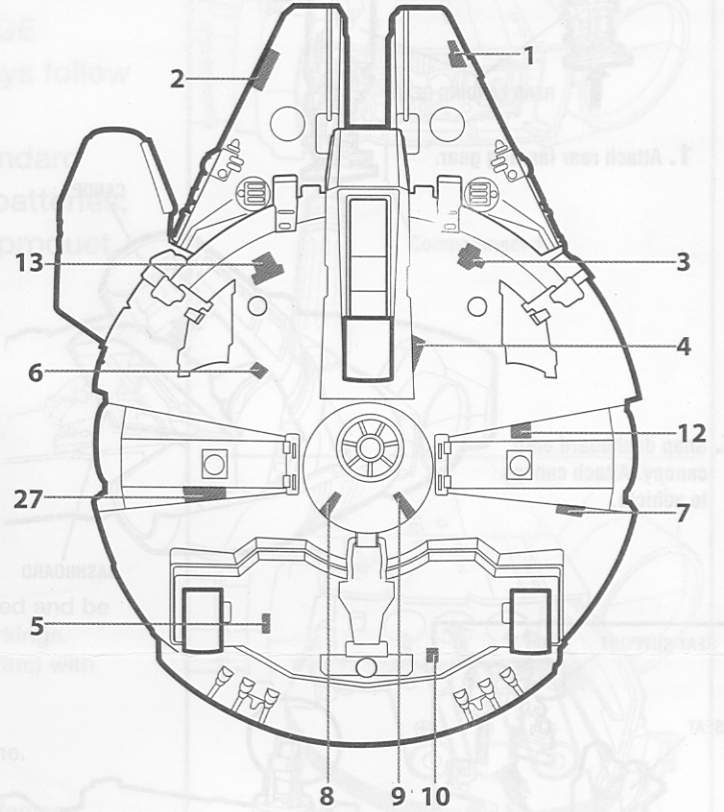
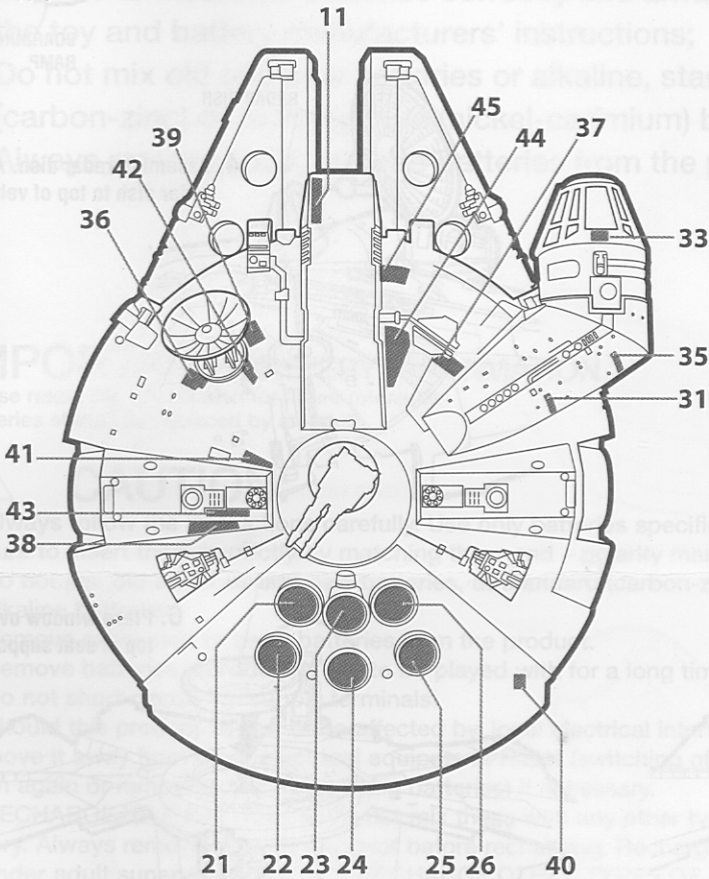

Some poses may require additional support.  
Product and colors may vary.  
© 2004 Lucasfilm Ltd. & © or TM where indicated. All rights reserved. Used under authorization.  
®\* and/or TM\* & © 2004 Hasbro. All Rights Reserved.  
© denotes Reg. U.S. Pat. & TM Office.

P/N 6357200000

# ASSEMBLY

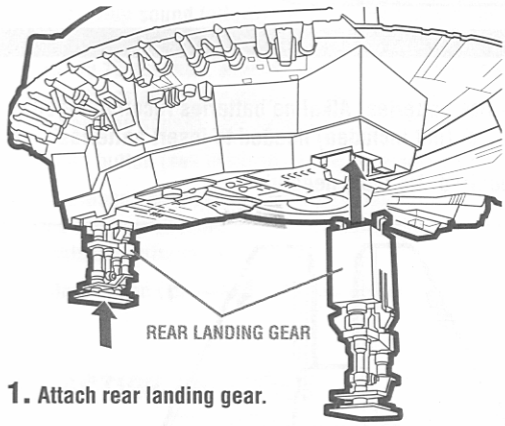

1. Attach rear landing gear.

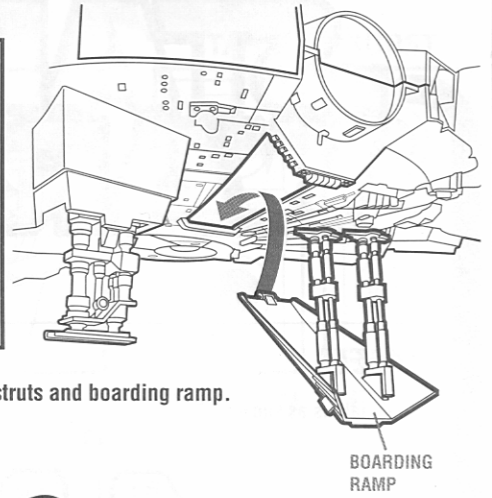
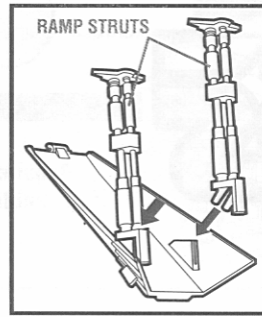

2. Attach ramp struts and boarding ramp.

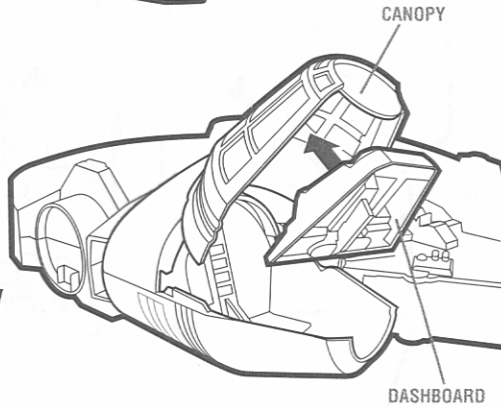

3. Snap dashboard onto canopy. Attach canopy to vehicle.

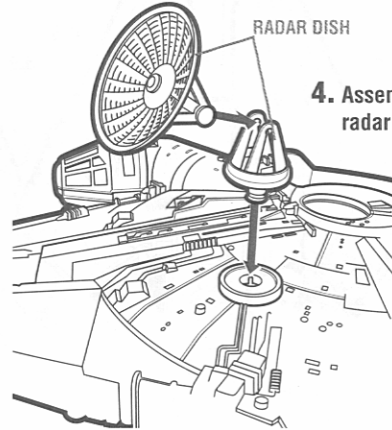

4. Assemble radar dish. Attach radar dish to top of vehicle.

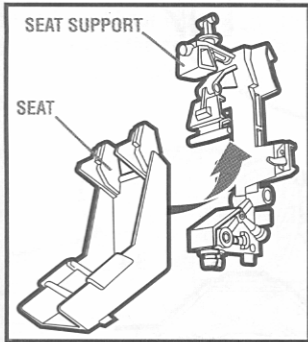

5. Attach seat to seat support. Attach seat support to floor of vehicle.

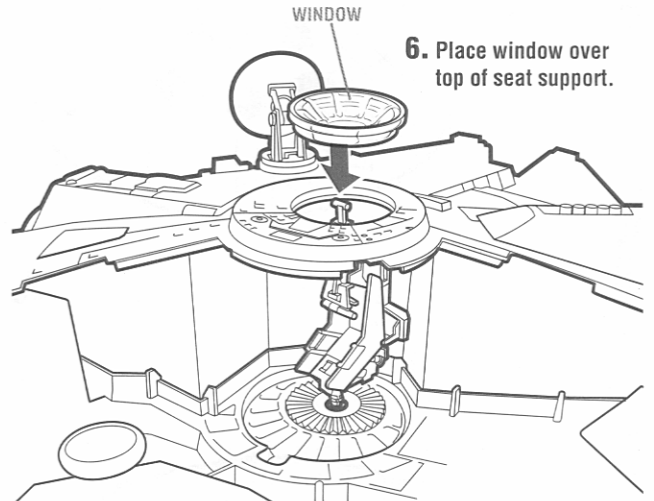
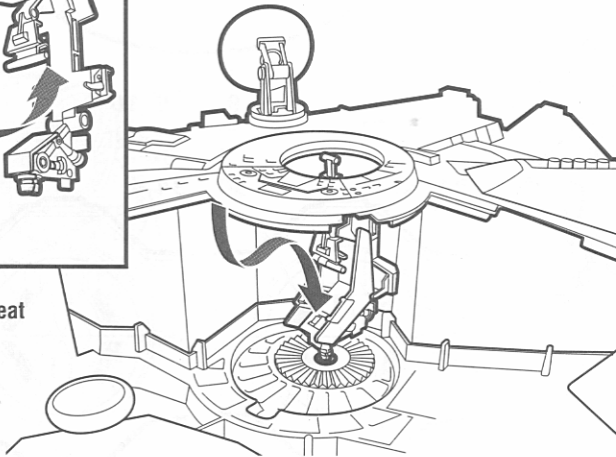

6. Place window over top of seat support.

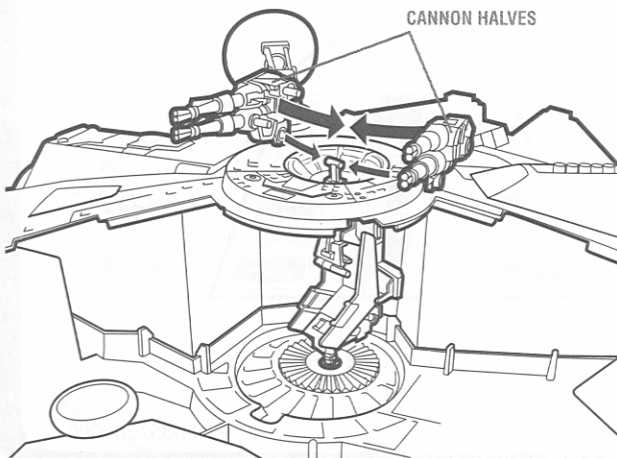

7. Attach cannon halves to top of seat support.

8. Place floor panel over hidden compartment.

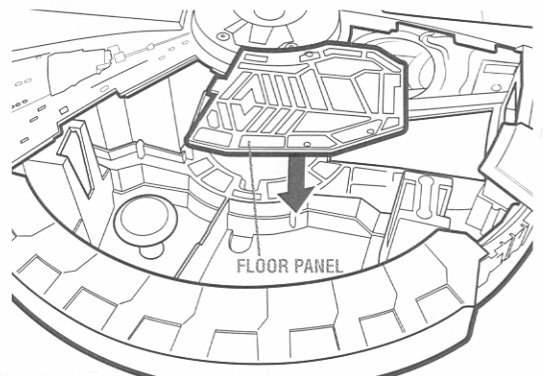

## INSERT BATTERIES

To insert batteries, loosen screw in battery compartment door with a Phillips/cross head screwdriver (not included). Remove door. Insert 3 x 1.5V "AA" or R6 size batteries. Alkaline batteries recommended. Replace door, and tighten screw.

### ! CAUTION: TO AVOID BATTERY LEAKAGE

1. Be sure to insert the batteries correctly and always follow the toy and battery manufacturers' instructions;
2. Do not mix old and new batteries or alkaline, standard (carbon-zinc) or rechargeable (nickel-cadmium) batteries;
3. Always remove weak or dead batteries from the product.

### IMPORTANT: BATTERY INFORMATION

Please retain this information for future reference.  
Batteries should be replaced by an adult.

### ! CAUTION:

1. Always follow the instructions carefully. Use only batteries specified and be sure to insert them correctly by matching the + and - polarity markings.
2. Do not mix old batteries and new batteries, or standard (carbon-zinc) with alkaline batteries.
3. Remove exhausted or dead batteries from the product.
4. Remove batteries if product is not to be played with for a long time.
5. Do not short-circuit the supply terminals.
6. Should this product cause, or be affected by, local electrical interference, move it away from other electrical equipment. Reset (switching off and back on again or removing and re-inserting batteries) if necessary.
7. RECHARGEABLE BATTERIES: Do not mix these with any other types of battery. Always remove from the product before recharging. Recharge batteries under adult supervision. DO NOT RECHARGE OTHER TYPES OF BATTERIES.

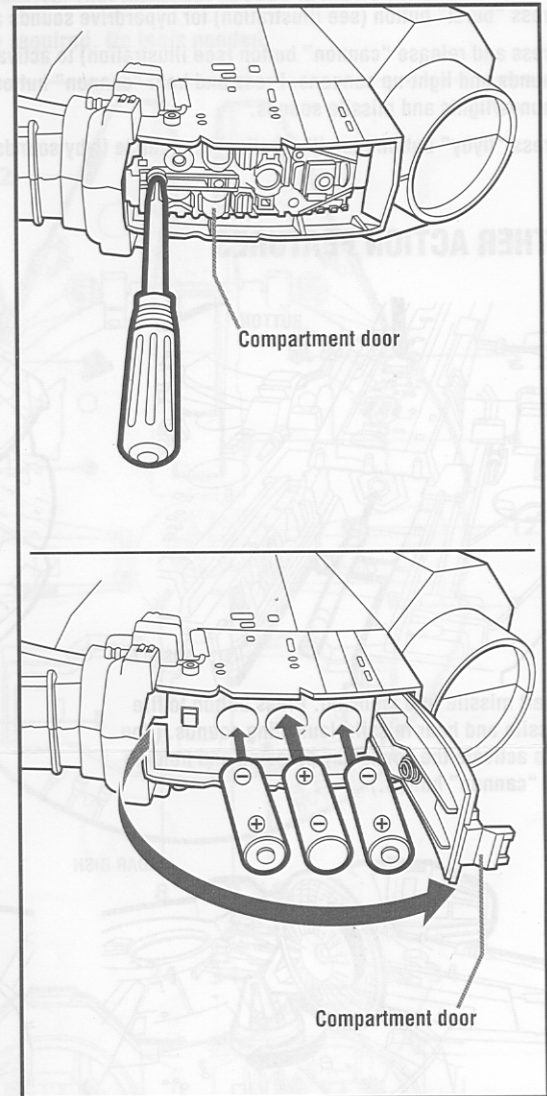

#### FCC Statement:

This equipment has been tested and found to comply with the limits for a Class B digital device, pursuant to part 15 of the FCC Rules. These limits are designed to provide reasonable protection against harmful interference in a residential installation. This equipment generates, uses and can radiate radio frequency energy, and, if not installed and used in accordance with the instructions, may cause harmful interference to radio communications. However, there is no guarantee that interference will not occur in a particular installation. If this equipment does cause harmful interference to radio or television reception, which can be determined by turning the equipment off and on, the user is encouraged to try to correct the interference by one or more of the following measures:

- Reorient or relocate the receiving antenna.
- Increase the separation between the equipment and receiver.
- Consult the dealer or an experienced radio/TV technician for help.

## SOUNDS/LIGHTS

Press "start" button (see illustration) to activate vehicle. You will hear an engine start-up sound followed by a cruising sound, and vehicle lights will illuminate. The sounds/lights will remain activated for approximately 15 seconds, at which time they will automatically power down. If you press any of the other buttons within the 15-second time period, the engine sounds and lights will stay activated.

Press "burst" button (see illustration) for hyperdrive sounds and lights.

Press and release "cannon" button (see illustration) to activate firing sounds and light-up cannons. Press and hold "cannon" button for firing sounds/lights and missile sounds.

Press "flyby" button (see illustration) for vehicle flyby sounds and lights.

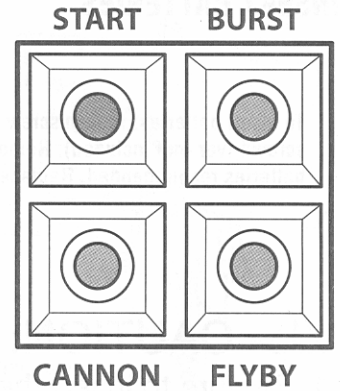
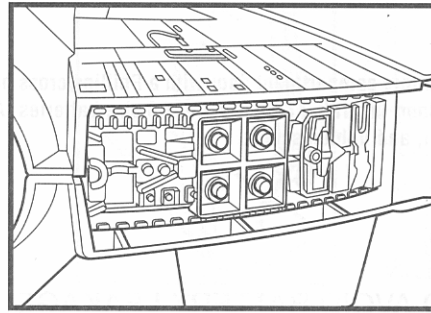

## OTHER ACTION FEATURES

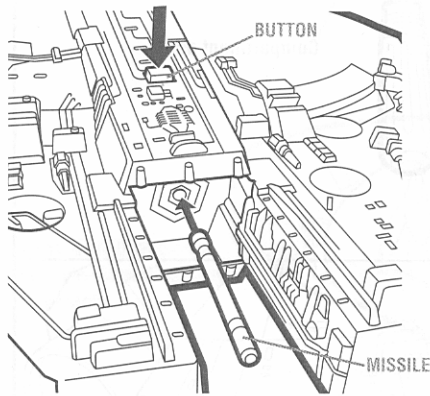

Insert missile into launcher. Press button to fire missile and hear missile-launching sounds. (You also activate the sounds by pressing and holding the "cannon" button.)

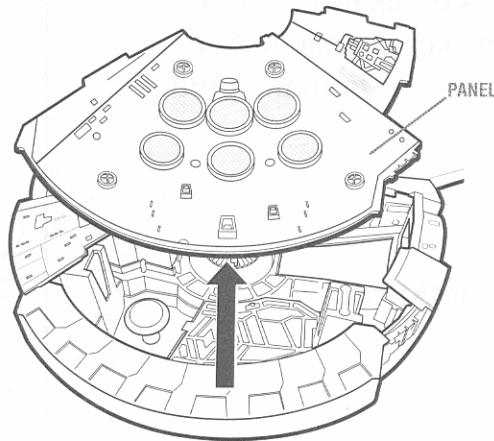

Remove panel to access the interior.

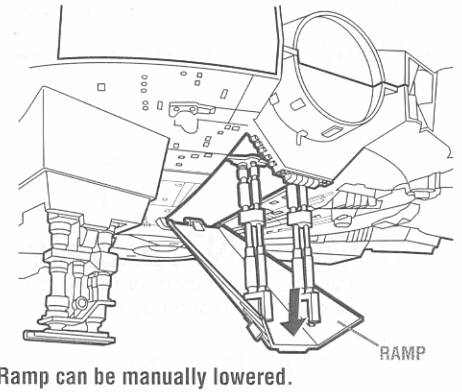

Ramp can be manually lowered.

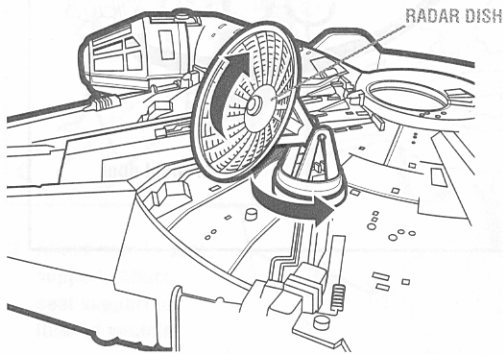

Positionable radar dish.

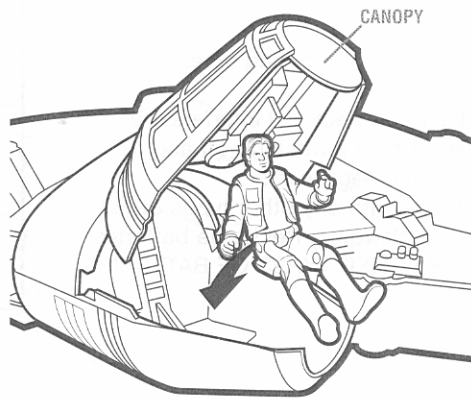

Canopy opens. Two figures (not included) can fit inside.

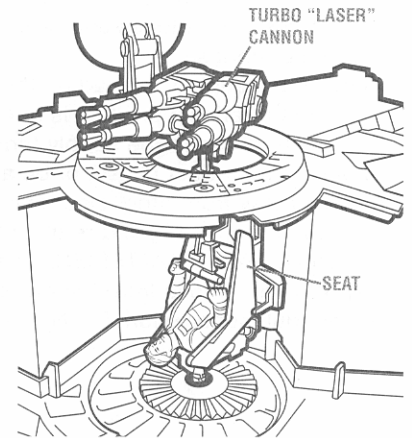

Rotating turbo "laser" cannon – inside the vehicle is an attached seat on which you can place a figure (not included).

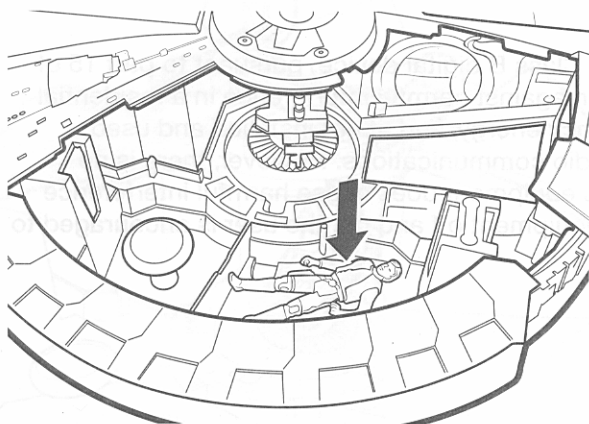

Lift floor panel to access hidden compartment. Store panel on underside of main access panel.

