

**OVER 9 months**

**05504**

**PLAYSKOOL**

# **Shoot 'n Score™ Basketball**

**Thank you for choosing this PLAYSKOOL brand product!**

**Includes 3 x 1.5V "AA"/R6 batteries. Alkaline batteries recommended. Phillips/crosshead screwdriver (not included) required for battery installation.**

**Parts included: Base, post, backboard/rim, plastic net, 1 ball.**

**Recommended for indoor use, away from direct sunlight, which interferes with toy's light technology.**

**Adult assembly required.**

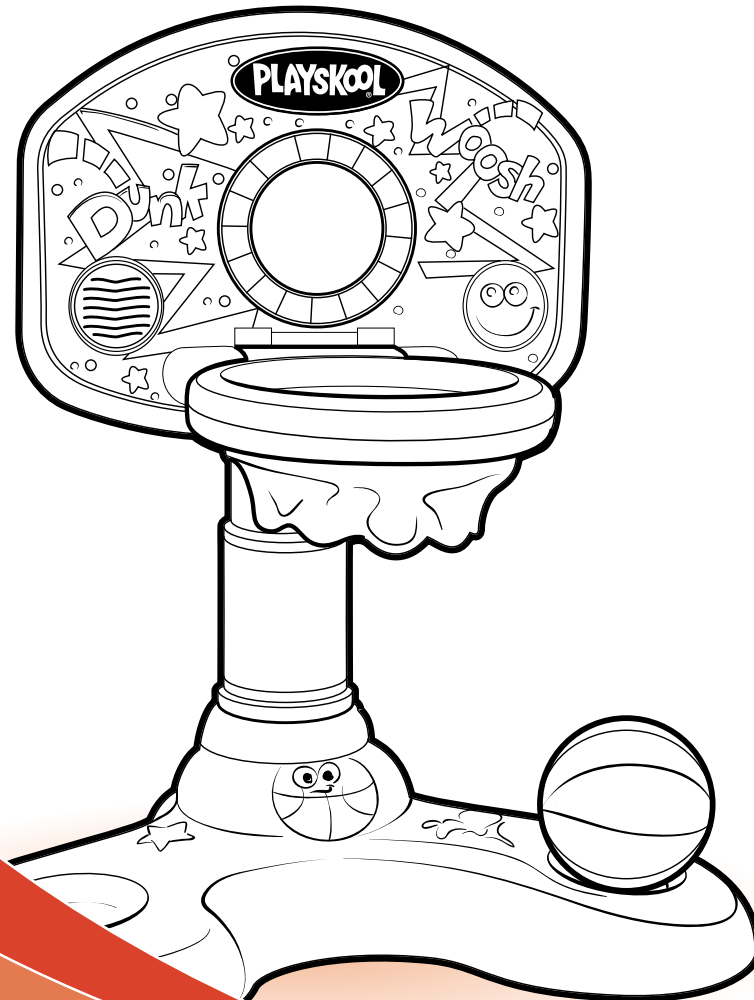

## Assembly

1. Flip rim up and snap into place to secure.

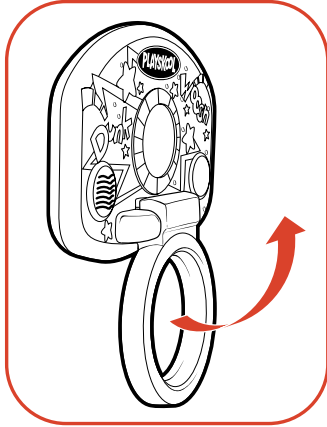

2. Snap plastic net onto bottom of rim.

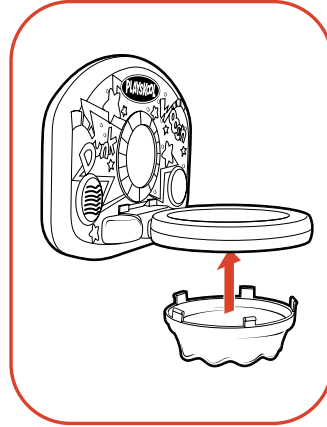

3. Snap post into base. Snap backboard onto post.

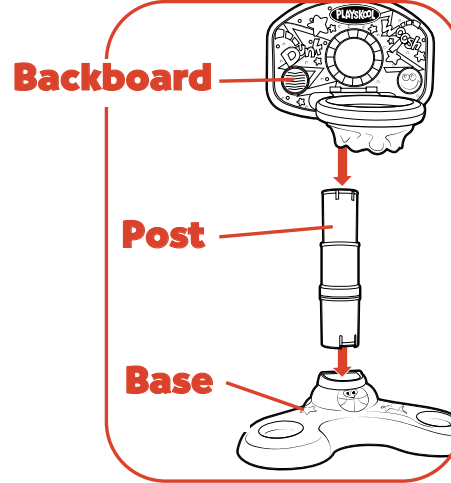

## Play Features

**Adults Note:** This product is shipped in "DEMO" mode. Slide switch to "HIGH VOLUME" or "LOW VOLUME" for full use at home.

- SHOOT 'N SCORE Basketball is an electronic, music-and-sounds toy that actually keeps score!
- This unique toy features 2 modes of play! Press the basketball button to choose a mode:
  - Counting:** When baby shoots the ball through the hoop, the animated announcer tallies the score - all the way up to 10!
  - Game:** The scoreboard tallies the number of baskets scored (up to 10) in 30 seconds. How many can you make?
- Adjust the height of the rim by pressing the button and moving the post up or down until it clicks into place! Grows with your baby!

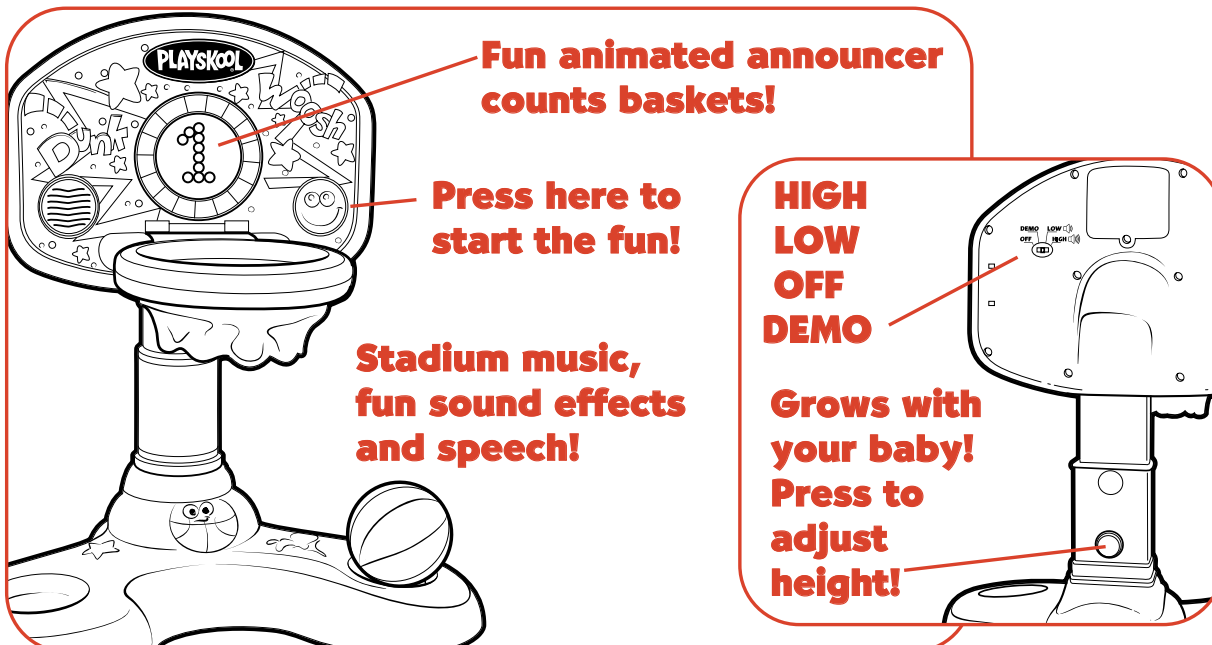

## Shutoff

- To shut off the toy during play, double press the basketball button. (Press button again to reactivate the toy.)
- If the toy is left inactive for a brief time, it will prompt baby to play again then shut off automatically.
- To disable electronics, slide the switch on back of toy to "OFF."

## To Replace Batteries

Use a Phillips/crosshead screwdriver to loosen screw in battery compartment door (screw remains attached to door). Remove old batteries. Insert 3 fresh "AA"/LR6 (1.5V) alkaline batteries. Replace door and tighten screw.

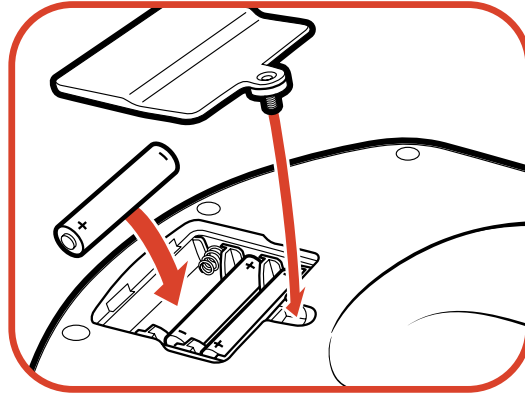

### CAUTION: TO AVOID BATTERY LEAKAGE

1. Be sure to insert the batteries correctly and always follow the toy and battery manufacturers' instructions.
2. Do not mix old and new batteries or alkaline, standard (carbon-zinc) or rechargeable (nickel-cadmium) batteries.
3. Always remove weak or dead batteries from the product.

### IMPORTANT: BATTERY INFORMATION

Please retain this information for future reference.  
Batteries should be replaced by an adult.

### CAUTION:

1. Always follow the instructions carefully. Use only batteries specified and be sure to insert them correctly by matching the + and - polarity markings.
2. Do not mix old batteries and new batteries or standard (carbon-zinc) with alkaline batteries.
3. Remove exhausted or dead batteries from the product.
4. Remove batteries if product is not to be played with for a long time.
5. Do not short circuit the supply terminals.
6. Should this product cause, or be affected by, local electrical interference, move it away from other electrical equipment. Reset (switching off and back on again or removing and re-inserting batteries) if necessary.
7. **RECHARGEABLE BATTERIES:** Do not mix these with any other types of battery. Always remove from the product before recharging. Recharge batteries under adult supervision. **DO NOT RECHARGE OTHER TYPES OF BATTERIES.**

## FCC STATEMENT

This equipment has been tested and found to comply with the limits for a Class B digital device, pursuant to Part 15 of the FCC Rules. These limits are designed to provide reasonable protection against harmful interference in a residential installation. This equipment generates, uses and can radiate radio frequency energy, and, if not installed and used in accordance with the instructions, may cause harmful interference to radio communications. However, there is no guarantee that interference will not occur in a particular installation. If this equipment does cause harmful interference to radio or television reception, which can be determined by turning the equipment off and on, the user is encouraged to try to correct the interference by one or more of the following measures:

- Reorient or relocate the receiving antenna.
- Increase the separation between the equipment and the receiver.
- Consult the dealer or an experienced radio/TV technician for help.

At Playskool, we want to do all we can to help ensure that children thrive developmentally. That's why we have partnered with the National Campaign for Hearing Health to provide you with this Hearing Checklist for babies.

### Your Baby's Hearing Checklist

Provided by  
National Campaign for Hearing Health  
1050 17th Street NW, Suite 701  
Washington, DC 20036



Talk to your doctor if you answer NO to any of these questions:

YES	NO	Birth to 3 Months
<input type="checkbox"/>	<input type="checkbox"/>	Reacts to loud sounds
<input type="checkbox"/>	<input type="checkbox"/>	Is soothed by your voice
<input type="checkbox"/>	<input type="checkbox"/>	Turns head to you when you speak
<input type="checkbox"/>	<input type="checkbox"/>	Seems to know your voice and quiets down if crying

YES	NO	3 to 6 Months
<input type="checkbox"/>	<input type="checkbox"/>	Looks upward or turns toward a new sound
<input type="checkbox"/>	<input type="checkbox"/>	Responds to "no" and changes in tone of voice
<input type="checkbox"/>	<input type="checkbox"/>	Enjoys rattles and other toys that make sounds
<input type="checkbox"/>	<input type="checkbox"/>	Becomes scared by a loud voice

The National Campaign for Hearing Health is sponsored by the Deafness Research Foundation. It is a public outreach, professional education and government relations initiative whose goal is to educate the public about hearing health.

Call the National Campaign for Hearing Health at **1.800.535.3323** or visit [www.hearinghealth.net](http://www.hearinghealth.net) for more information.

Based on NIDCD/NIH infant hearing checklist.

