

TO REPLACE BATTERIES

Use a Phillips/cross head screwdriver to loosen screw in battery compartment door located on the bottom of the SIT 'N SPIN base (screw remains attached to door). Remove door. Remove and discard batteries. Insert 2 x 1.5V "AA" or R6 size batteries. Alkaline batteries recommended. Replace door and tighten screw.

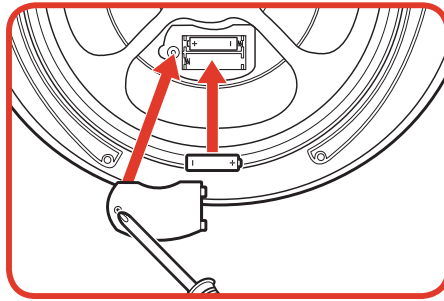

⚠ CAUTION: TO AVOID BATTERY LEAKAGE

1. Be sure to insert the batteries correctly and always follow the toy and battery manufacturers' instructions;
2. Do not mix old and new batteries or alkaline, standard (carbon-zinc) or rechargeable (nickel-cadmium) batteries;
3. Always remove weak or dead batteries from the product.

IMPORTANT: BATTERY INFORMATION

Please retain this information for future reference. Batteries should be replaced by an adult.

⚠ CAUTION:

1. Always follow the instructions carefully. Use only batteries specified and be sure to insert item correctly by matching the + and - polarity markings.
2. Do not mix old batteries and new batteries or standard (carbon-zinc) with alkaline batteries.
3. Remove exhausted or dead batteries from the product.
4. Remove batteries if product is not to be played with for a long time.
5. Do not short circuit the supply terminals.
6. Should this product cause, or be affected by, local electrical interference, move it away from other electrical equipment. Reset (switching off and back on again or removing and re-inserting batteries) if necessary.
7. **RECHARGEABLE BATTERIES:** Do not mix these with any other types of battery. Always remove from the product before recharging. Recharge batteries under adult supervision. **DO NOT RECHARGE OTHER TYPES OF BATTERIES.**

FCC STATEMENT

This equipment has been tested and found to comply with the limits for a Class B digital device, pursuant to Part 15 of the FCC Rules. These limits are designed to provide reasonable protection against harmful interference in a residential installation. This equipment generates, uses and can radiate radio frequency energy, and, if not installed and used in accordance with the instructions, may cause harmful interference to radio communications. However, there is no guarantee that interference will not occur in a particular installation. If this equipment does cause harmful interference to radio or television reception, which can be determined by turning the equipment off and on, the user is encouraged to try to correct the interference by one or more of the following measures:

- Reorient or relocate the receiving antenna.
- Increase the separation between the equipment and the receiver.
- Consult the dealer or an experienced radio/TV technician for help.



MARVEL, Spider-Man & Friends, and all related character names and the distinctive likeness thereof are trademark of Marvel Characters, Inc., and are used with permission. Copyright © 2006 Marvel Characters, Inc. All rights reserved. www.marvel.com. Produced under license from Marvel Characters, Inc.

®* and/or TM* and © 2006 Hasbro. All Rights Reserved.
TM & © denote U.S. Trademarks.

34891/34890

P/N 6633830000

Visit
PLAYSKOOL
.com

OVER 18 Months to 5½ Years

34891/34890

PLAYSKOOL



Sit 'n Spin®*

Includes: SIT 'N SPIN base, center post (2 pieces), 3 screws and turn handle.

Adult assembly required.

Phillips/cross head screwdriver (not included) needed for assembly.

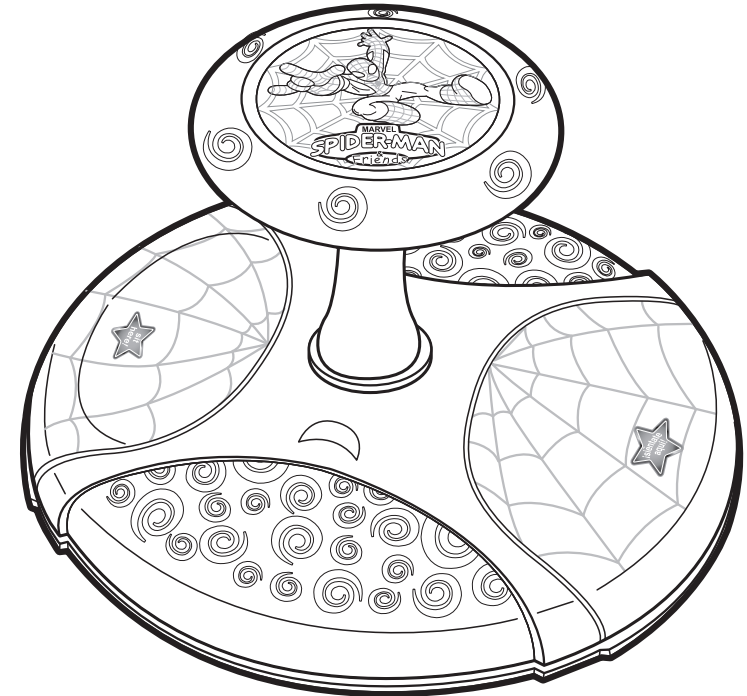

Thank you for purchasing
this **PLAYSKOOL** toy!

X2 1.5V AA or R6 size
BATTERIES INCLUDED

Replace with 2x 1.5V AA or R6 size batteries.
Follow instructions on packaging. Batteries used
constantly (not including one that is replaced initially).

⚠ CAUTION:

This product contains small parts which are necessary for the assembly. Prior to and during assembly of this product, keep small parts out of children's reach. Small parts pose a choking hazard to children under 3 years.

ASSEMBLY: Here are the easy-to-follow instructions for assembling your SPIDER-MAN & FRIENDS SIT 'N SPIN toy. Please follow assembly instructions in proper order for best results.

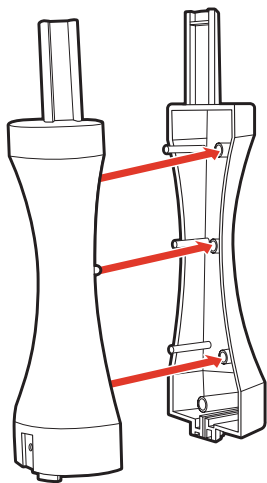

1. Connect the right side and left side of the center post by snapping the two pieces together. This is a one-time assembly.

2. Use a Phillips/cross head screwdriver (not included) and 2 screws (included) to connect the turn handle to the top of the center post. The screws connect on the sides of the turn handle as shown.

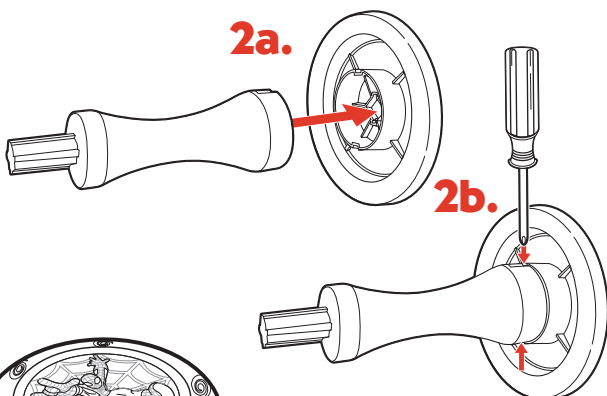

3. Place the center post/turn handle into the SIT 'N SPIN base as shown. Flip the SIT 'N SPIN base over and use a Phillips/cross head screwdriver and 1 screw (included) to connect the center post/turn handle to the base.

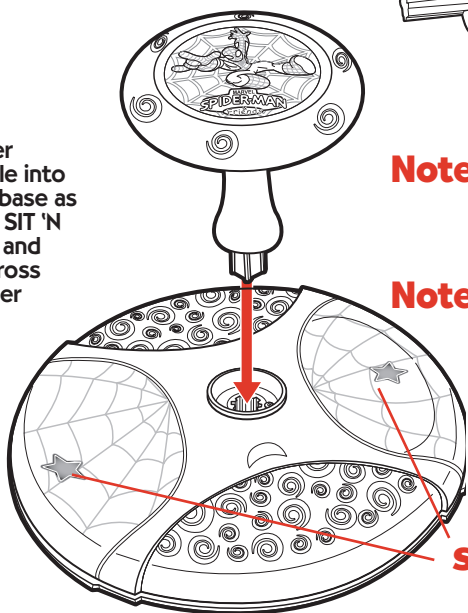

Note: Check to be sure that all assembled parts are securely attached before using the toy.

Note: For best performance, child should be seated on one of the two designated seating areas marked with the red star.

seating areas

NOW YOU'RE READY TO PLAY!

PLAY FEATURES: Your child can keep the fun spinning as he hears music and fun phrases! Here are some play suggestions to get you started:

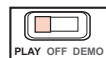

NOTE: This toy is packaged in "Demo" mode. To enable full play features, change to "Play" mode located on the underside of the toy. This toy also features a sounds-off mode for quiet play! Simply move the switch at the bottom of the toy to "Off."

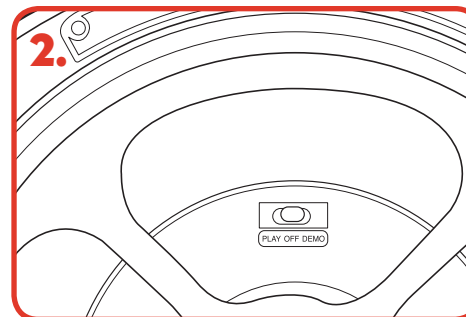
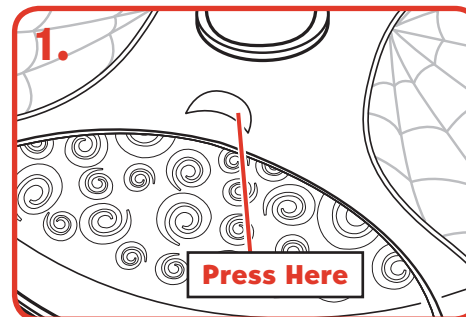

1. Push the moon-shaped button on the top of the SIT 'N SPIN base or spin the base to start the theme song and hear fun phrases. You may press the moon-shaped button on the top of the SIT 'N SPIN base to switch to giggles and web-slinging sound effects, or you may continue spinning and the toy will automatically switch.

Music and Fun Phrases

Spider-Man® will encourage a "spin"-along!

Giggles and Sound Effects

Spider-Man® will giggle as your child hears web-slinging sound effects while spinning!

2. After several seconds of inactivity, the toy will automatically shut off. To play again, simply spin the base or press the moon-shaped button. When storing, make sure the three-position switch on the bottom of the toy is moved to "Off" position to conserve battery life.