



LABEL APPLICATION

1. Apply labels to unassembled parts using the numbers on the label sheet and these illustrations as a guide.

MAIN SHIP

Right Wing

Left Wing

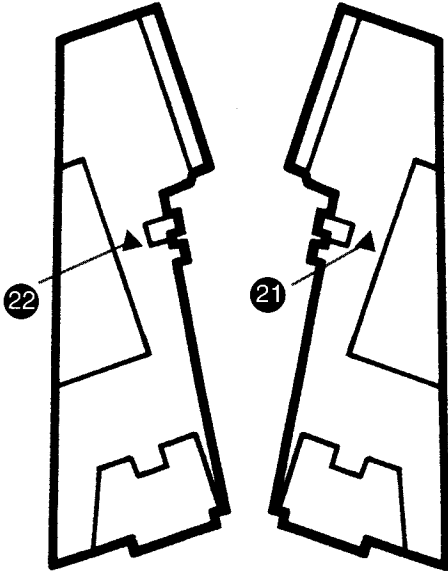

Main Ship

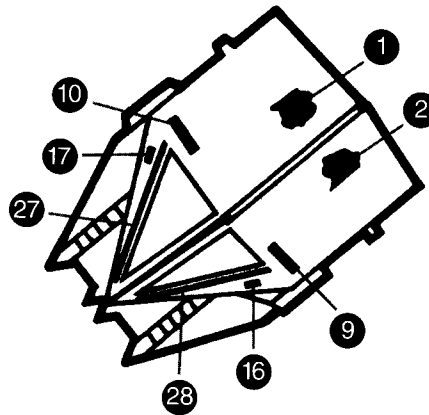

Stabilizer

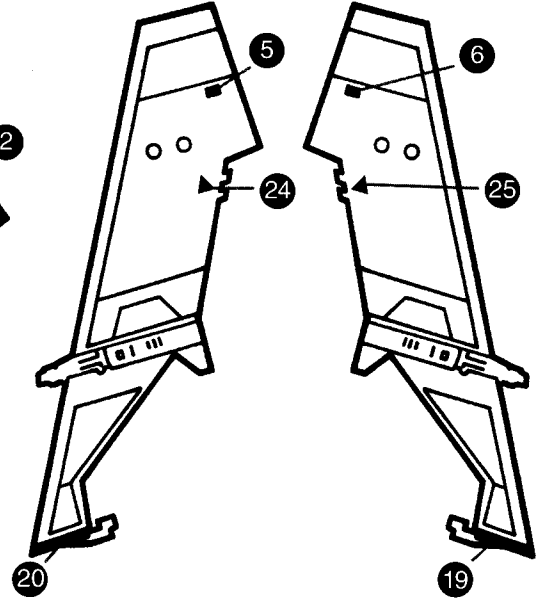

Left Side

Right Side

COCKPIT VEHICLE

Front side

Right Side

Left side

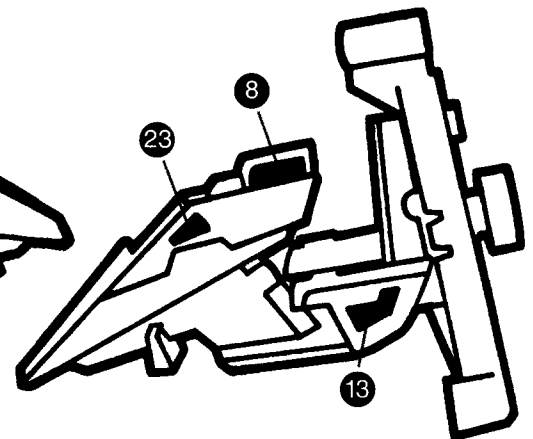
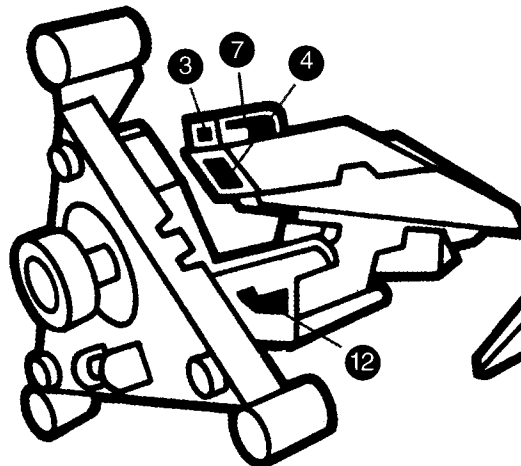
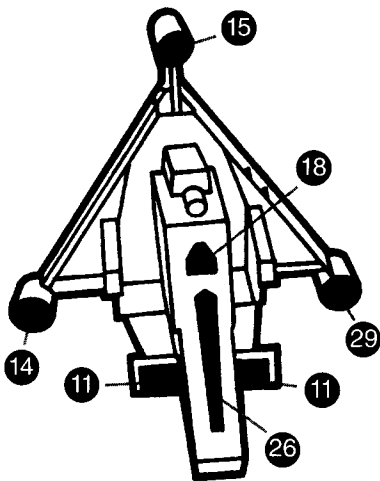

Kenner®

© & © 1996 HASBRO, INC.,
Pawtucket, Rhode Island 02862.
All Rights Reserved.

TM & © 1996 Lucasfilm Ltd.
All rights reserved.
Used under authorization.

MADE IN MEXICO.

ASSEMBLY & PLAY

2. Attach **main stabilizer** to main ship as shown.

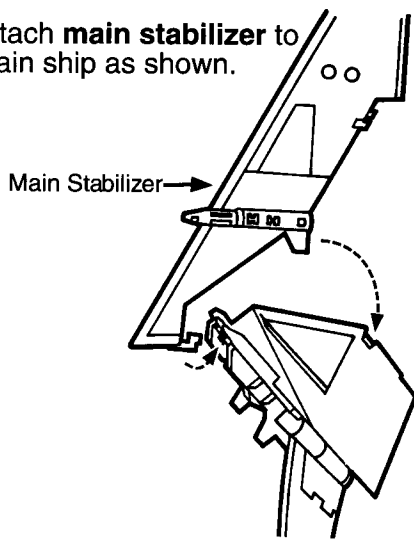

3. Attach **wings** to main ship as shown. Wings can be moved up and down.

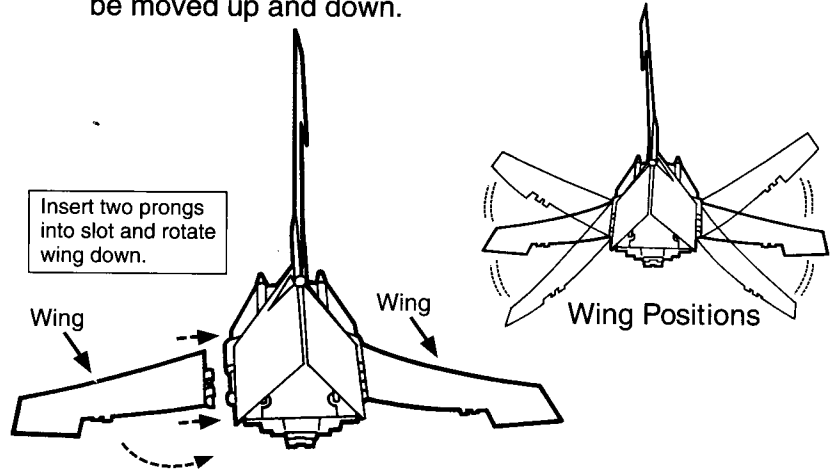

4. Attach **rear stabilizer** to cockpit vehicle by inserting pegs one at a time into the connector tube as shown.

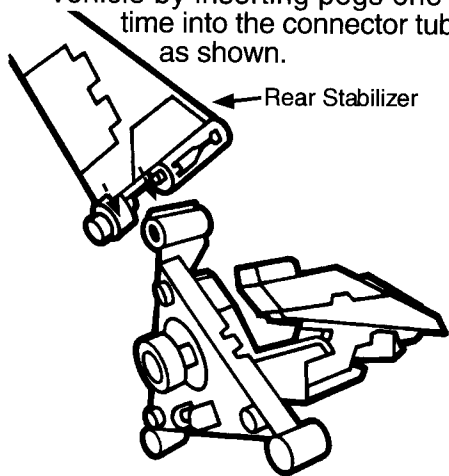

5. Attach **small wings** to cockpit vehicle in the same way as the stabilizer. Wings can be moved up and down.

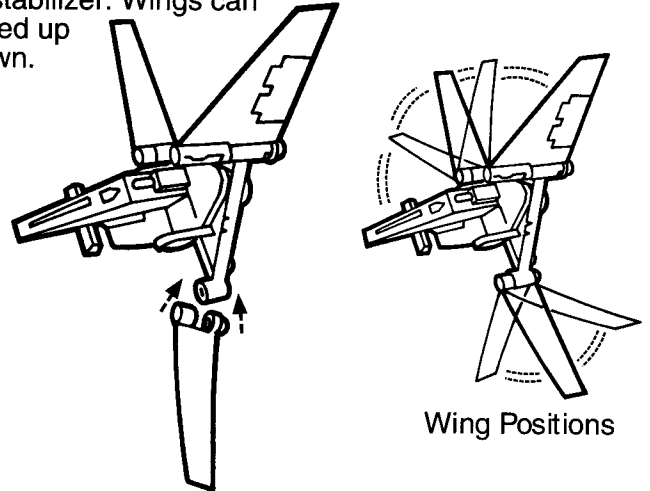

6. Cockpit vehicle nests inside main ship as shown. Wings and stabilizers fit together. Place figure (sold separately) in the pilot seat as shown.

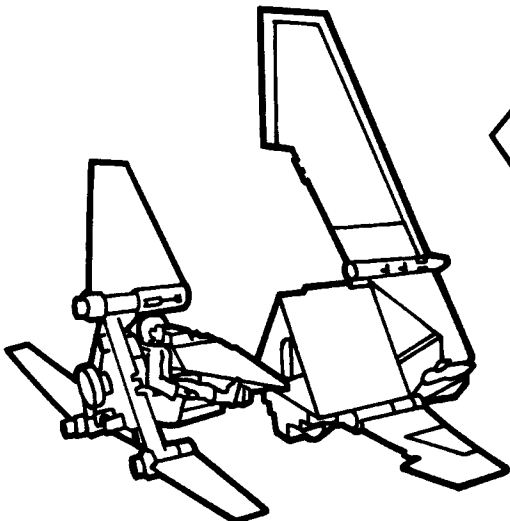

7. Insert projectile into cannon as shown. Push button to fire.

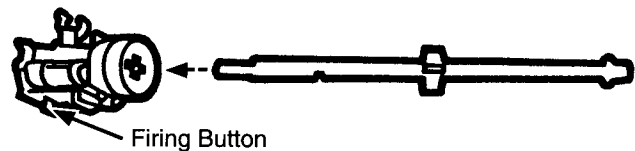

8. Launcher snaps onto main ship or cockpit vehicle.

