

CAPCOM

# STREET FIGHTER™

THE WORLD WARRIOR™

## KARATE CHOPPER™ INSTRUCTIONS

**WARNING**  
 Contains Small Parts Which Pose  
 a Choke Hazard For Children  
 Under the Age of Three.  
**Ages: 5 & Up**  
 Remove all pieces from plastic frames.  
 If you have difficulty use safety scissors.

**CONTAINS:** Body halves (2), front wheel, front fork halves (2), driver's seat, turret, turret platform, gunner's seat, exhaust pipes (2), rear wheels (2), rear axle, handlebars, windscreen, shields (2), missile launcher, launcher holder, missiles (2) and label sheet.

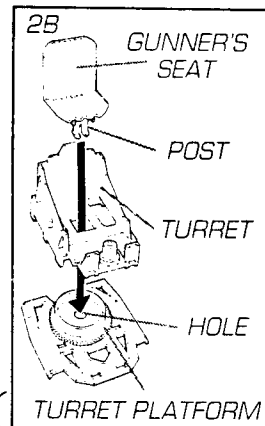
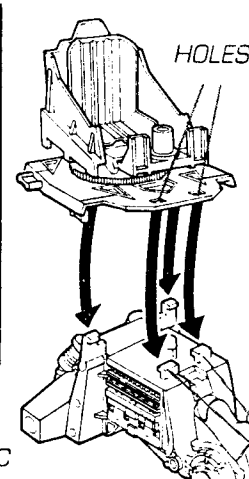
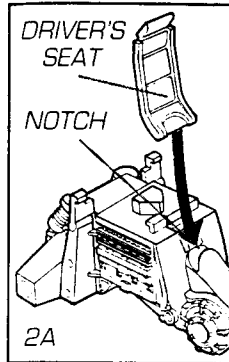
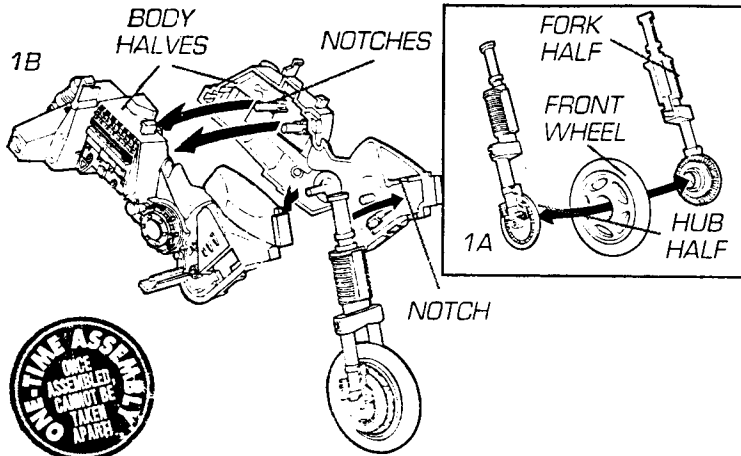

### 1. FRONT WHEEL/BODY ASSEMBLY

Place front wheel between hub halves. Snap hub halves/fork halves together (ILL. 1A). Insert top of fork into notch between body halves as shown. Line up fork with other notches in body half and snap halves together (ILL. 1B).

### 2. SEAT/TURRET ASSEMBLY

Place driver's seat into notch in body (ILL. 2A). Insert post on gunner's seat through hole in turret, then snap post through hole in turret platform (ILL. 2B). Snap tabs (4) behind driver's seat through holes in turret platform (ILL. 2C).

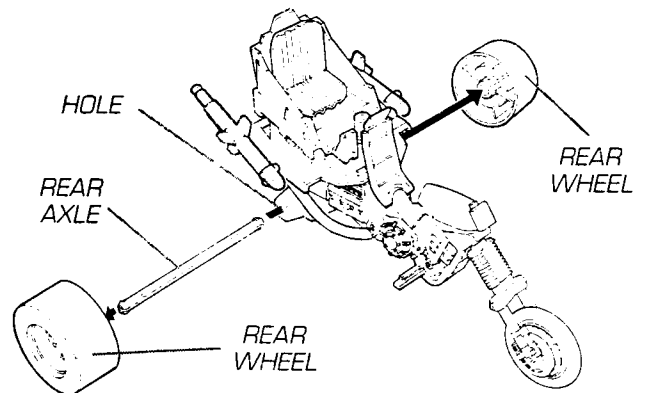
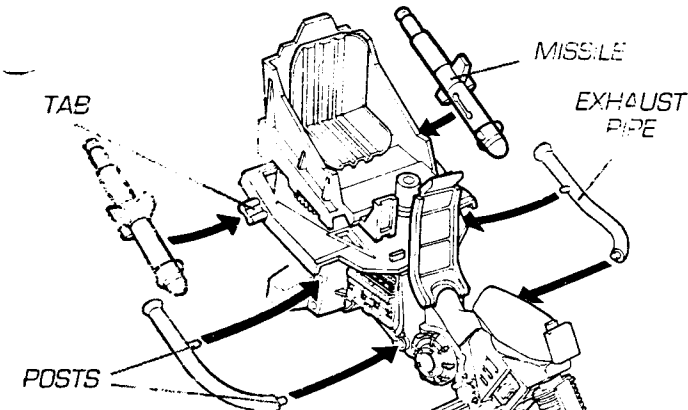

### 3. ATTACHING EXHAUST PIPES & MISSILES

Fit posts on exhaust pipes into holes in body sides. Fit slots in missiles (2) onto tabs below each side of turret platform.

### 4. REAR WHEEL/AXLE ASSEMBLY

Snap rear axle through the INSIDE of one rear wheel. Insert other end of axle through hole in rear of body. Snap other rear wheel over end of axle.

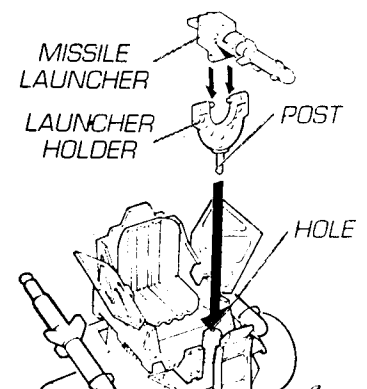
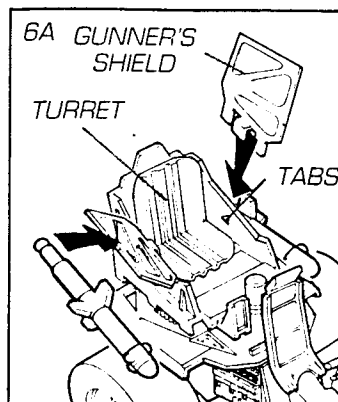
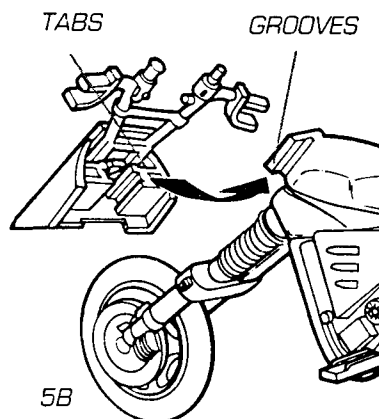
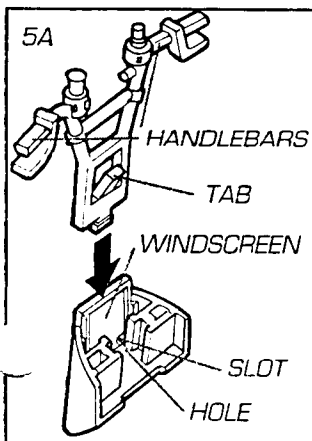

### 5. HANDLEBARS ASSEMBLY

Slide handlebars through slot in windscreen and snap bottom tab on handlebars through hole (ILL. 5A). Slide grooves in windscreen over front tabs as shown (ILL. 5B).

### 6. SHIELD/MISSILE LAUNCHER ASSEMBLY

Snap gunner's shields over tabs on each side of turret as shown (ILL. 6A). Snap missile launcher onto launcher holder, then snap holder post into hole as shown.

# KARATE CHOPPER™

## OFFICIAL VEHICLE SPECIFICATIONS

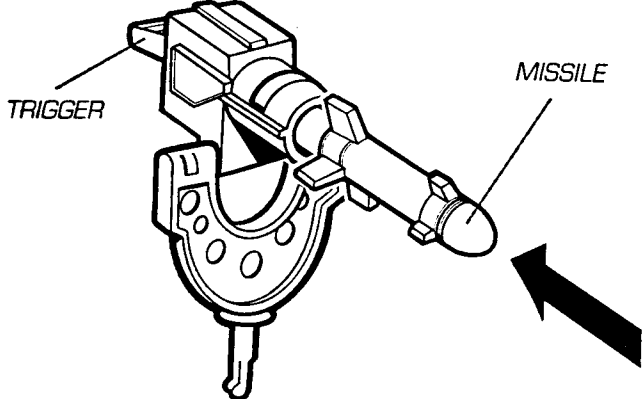

### 7. FIRING MISSILE LAUNCHER

Insert missile into launcher barrel and lock in place. To fire, press trigger. **CAUTION:** Do not aim launcher at eyes or face.

1. ROTATING TURRET WITH GUNNER'S SEAT
2. FAST-FIRE MISSILE LAUNCHER
3. CHOPPER-STYLE FRONT FORKS
4. ARMORED WINDSCREEN
5. STREET BLASTIN' POWER PLANT
6. EXTRA-WIDE REAR TIRES
7. DUAL EXHAUST PIPES
8. ARMOR-PLATED GUNNER'S SHIELDS

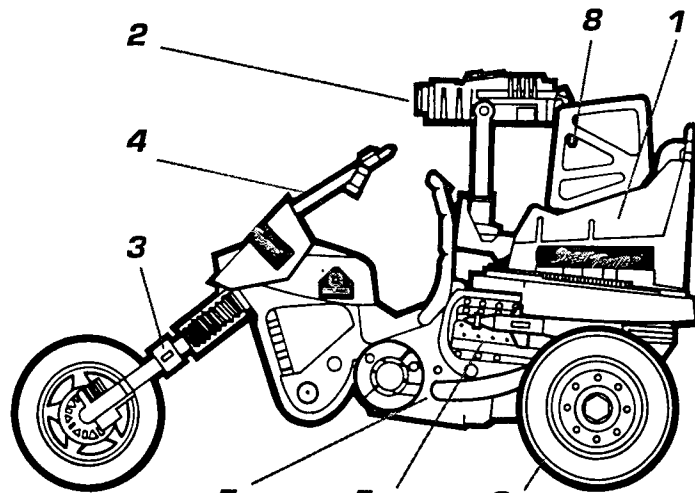

### 8. PEEL AND APPLY LABELS AS SHOWN.

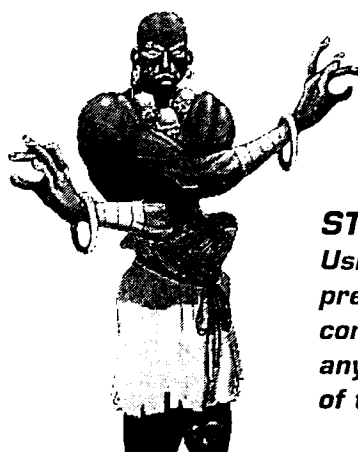
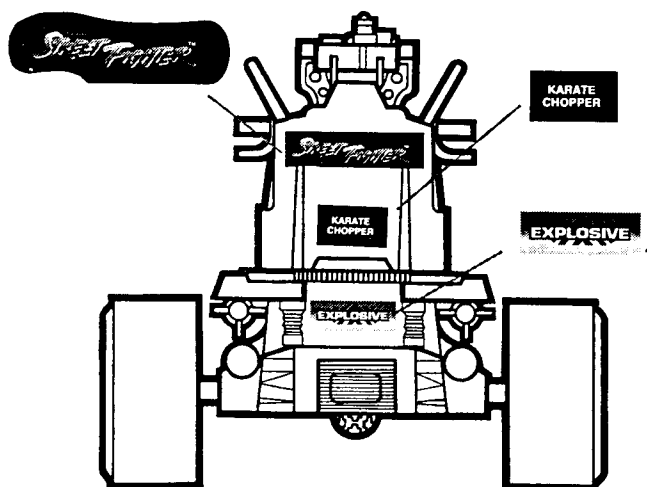
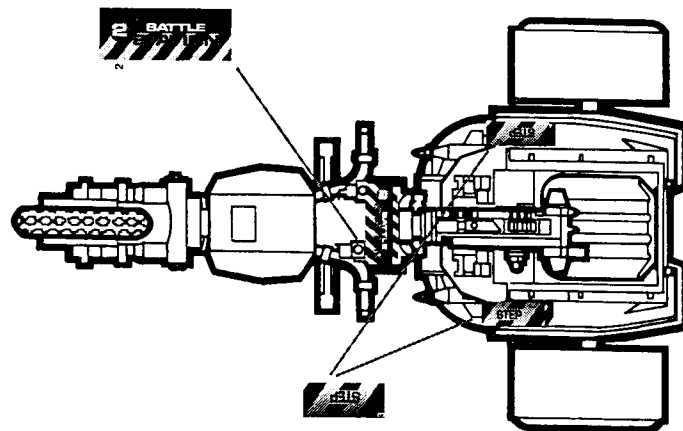
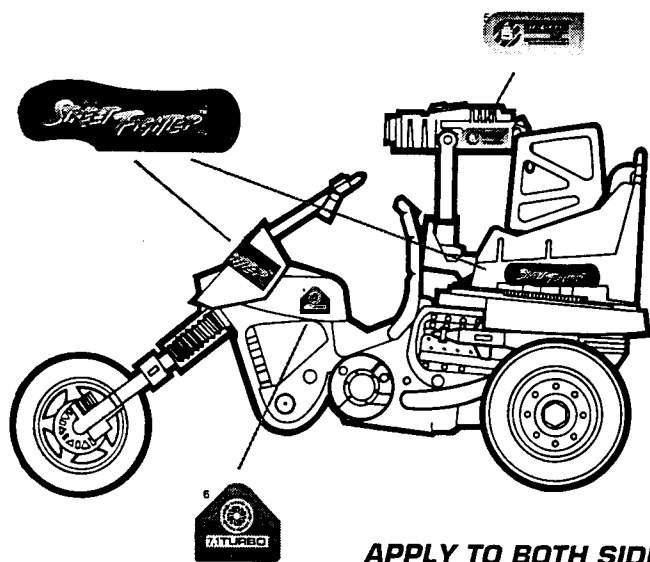

SECRET  
CAPCOM  
**SECRET**  
GAME PLAYING TIP  
FOR VIDEO GAME  
CHARACTER DHALSIM!

### STUNNING YOGA FIRE:

Using the joystick, press ← ↓ → in one continuous motion and press any Punch button at the end of the joystick motion.