

6 ASSEMBLY OF THE RIGHT LEGS

INSERT ⑧ & ⑬, ⑧ & ⑭ AS SHOWN.

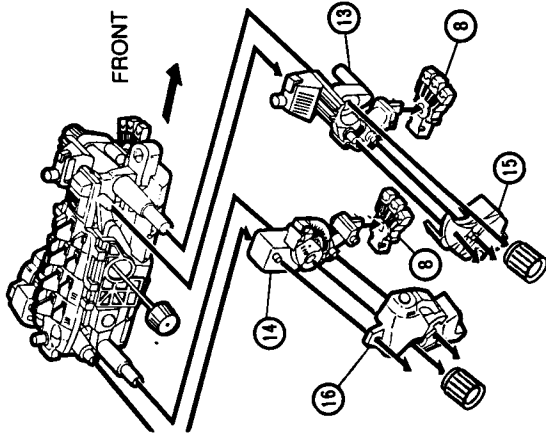

7 ASSEMBLY OF THE HEAD

SLIDE LOWER JAW INTO UPPER JAW.

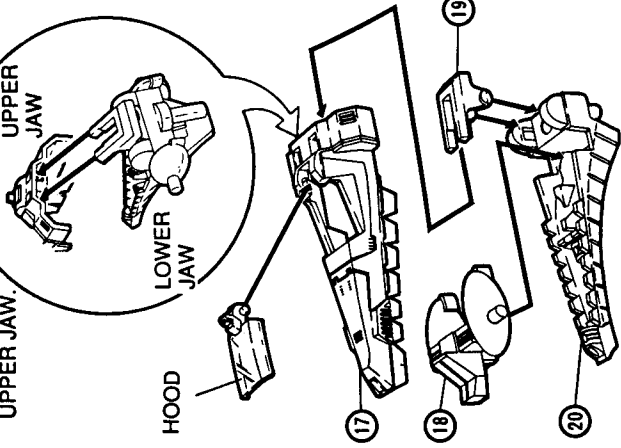

8 PILOT

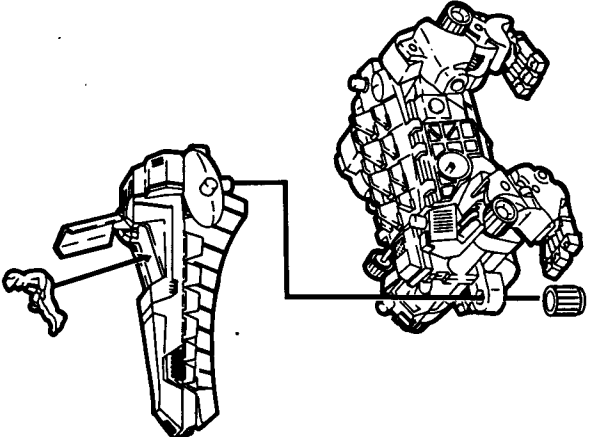

10 ASSEMBLY OF THE TAIL

ASSEMBLE ⑫ & ⑬ TO THE REAR. HOLD PARTS IN PLACE AS YOU INSERT TAIL AS SHOWN. ATTACH CAP TO HOLD PARTS TOGETHER.

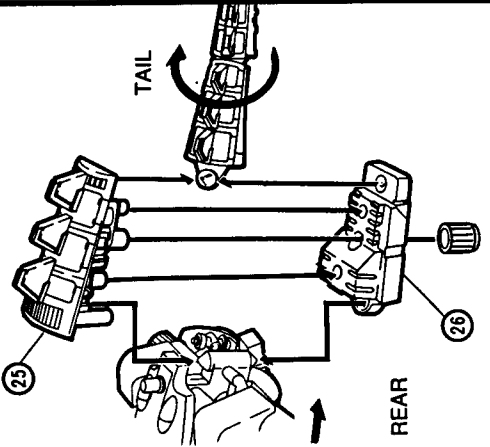

11 ASSEMBLE ⑰ & ⑱ SO THAT THEY DON'T TOUCH AT THE HEAD.

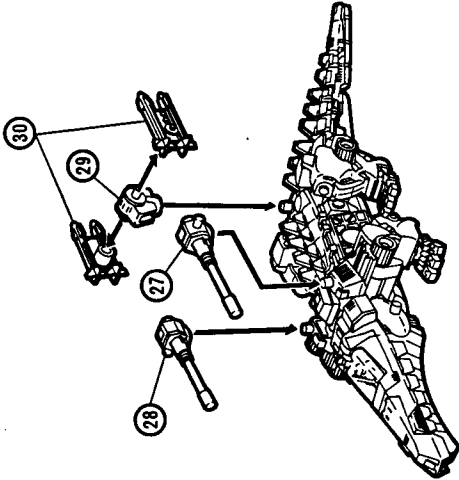

TO OPERATE: WIND UP THE MOTOR. PLACE TOY ON A SMOOTH, HARD, LEVEL SURFACE FOR BEST MOVEMENT.

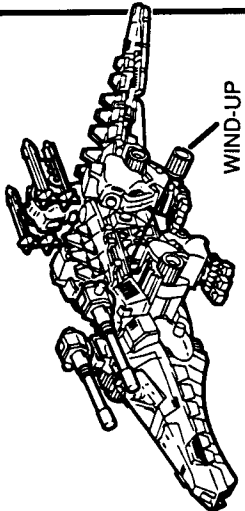

Kenner
©1994 Kenner, a Division of Tonka Corporation, Cincinnati, Ohio 45202

51473800

9 ASSEMBLY OF THE TAIL

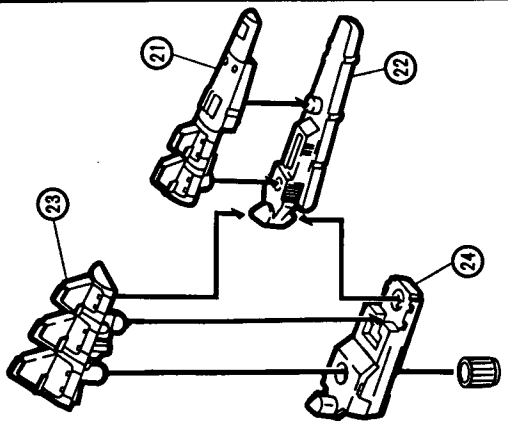

**TECHNO
ZOIDZ**

**ARMORED
GATOR™**

6/18/92

IMPORTANT

- Please read this **BEFORE** you begin.
- Read and follow all instructions in order. Do not skip around when assembling this toy.
 - Lay out all parts as shown in Parts Panel before you begin to assemble your toy. This will enable you to identify the parts and familiarize yourself with the numbering system.
 - Before you remove any part, make sure you have checked that the number on the part matches the number in the instruction drawing.
 - To avoid breaking, carefully trim parts from the frame using a nail clipper, wire cutter or similar household tool. Remove any excess plastic from the part before snapping the parts together. You do **not** need glue to hold the parts together. Assemble the part before removing another part from the frame. You may have to hold some parts together in the process.
 - After following the step-by-step assembly, your toy will be ready for play.

PARTS PANEL

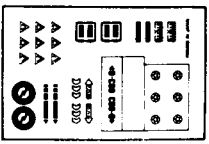
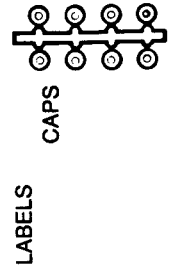
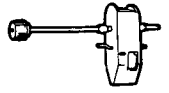
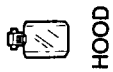

APPLY LABELS AS YOU LIKE.

1 ASSEMBLE WIND-UP UNIT

ASSEMBLE WIND-UP UNIT TO ② FIRST. THEN ASSEMBLE ① TO ② BRINGING THEM TOGETHER THEN SLIDING ① DOWN OVER HOOKS ON ② AS SHOWN BELOW.

FRONT VIEW

HOOK

5 ASSEMBLY OF THE LEFT LEGS

FRONT

INSERT ⑧ & ⑨, ⑩ & ⑪ AS SHOWN

4 PART ⑦ WILL SNAP OVER PARTS ④ & ⑥ TO HOLD ASSEMBLY TOGETHER

FRONT

HOLD ASSEMBLY TOGETHER UNTIL YOU SNAP PART ⑦ IN PLACE.

3 ASSEMBLY OF THE RIGHT SIDE

FRONT

ASSEMBLY OF THE RIGHT SIDE

2 ASSEMBLY OF THE LEFT SIDE

FRONT

ASSEMBLY OF THE LEFT SIDE