

AGES 3 AND UP

CAUTION: Hair entanglement may result if child's hair comes in contact with moving wheels of toy. Adult supervision is required.

WARNING:
CHOKING HAZARD - Small parts. Not for children under 3 years.

POWER EDGE TRUCK™

INSTRUCTIONS

LABEL APPLICATION

Apply labels to the unassembled pieces using the numbers on the label sheet and these illustrations as a guide.

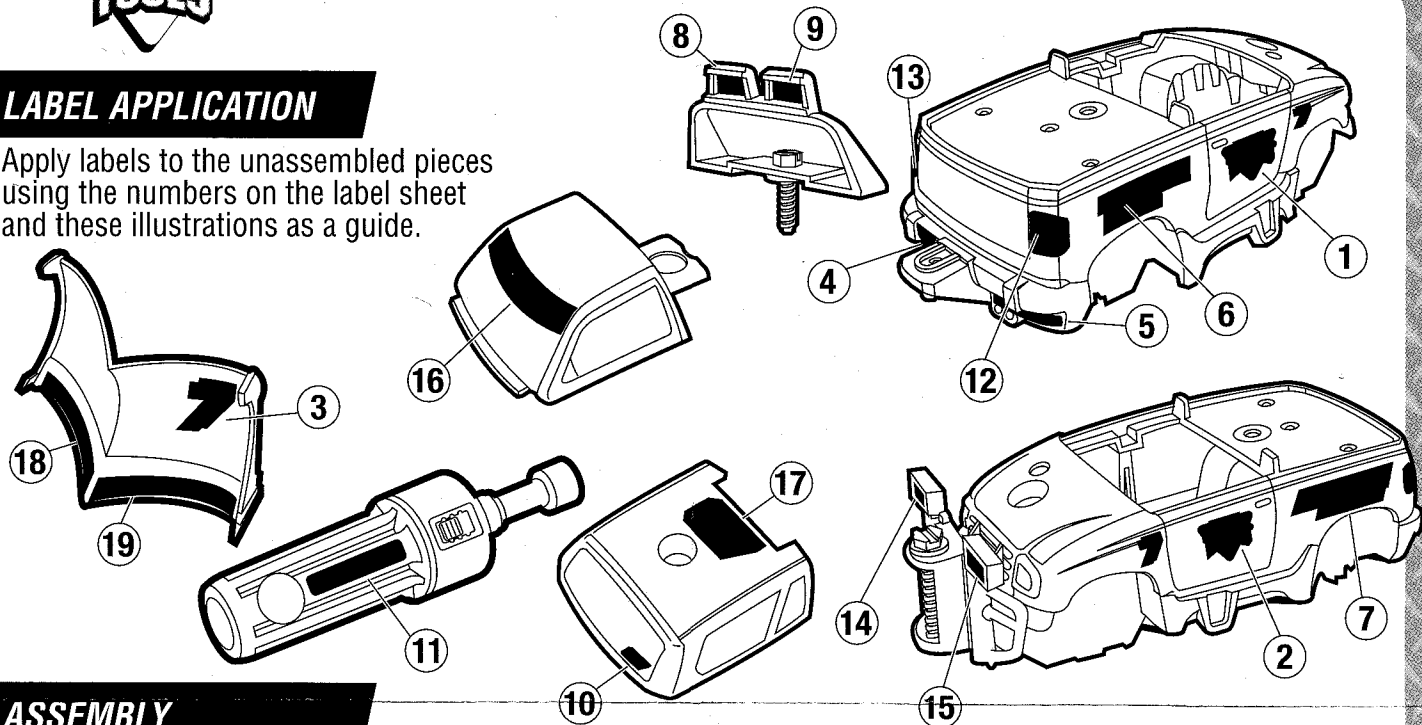

ASSEMBLY

1. **ONE-TIME ASSEMBLY**
Once assembled, cannot be taken apart! Snap the Red ON/OFF Button into the Front Wheel Assembly as shown.

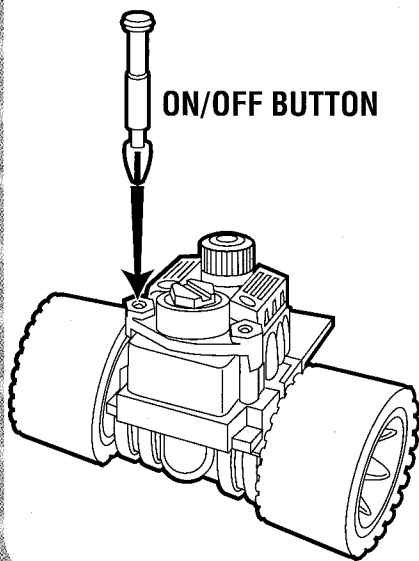

2. Assemble the parts in the order indicated.

A. Insert the Front Wheel Assembly into position as shown. Tighten the screws with the Ratchet-Driver.

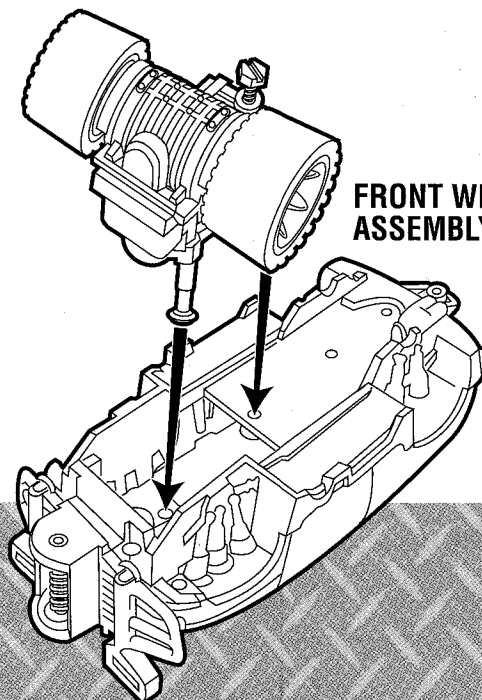

B. Insert the Back Wheel Assembly into position as shown. Tighten the screws with the Ratchet-Driver.

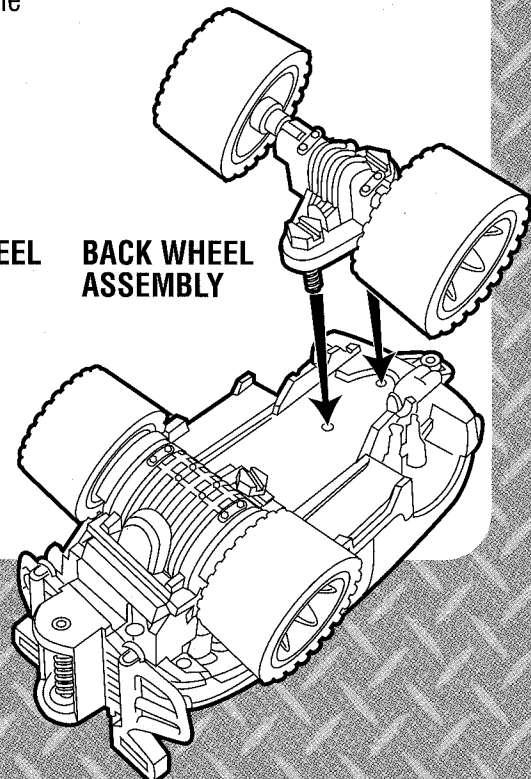

POWER EDGE™ BLADE

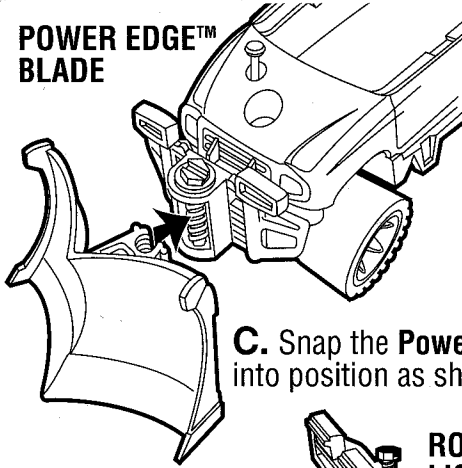

C. Snap the **Power Edge™ Blade** into position as shown.

CAB FRONT

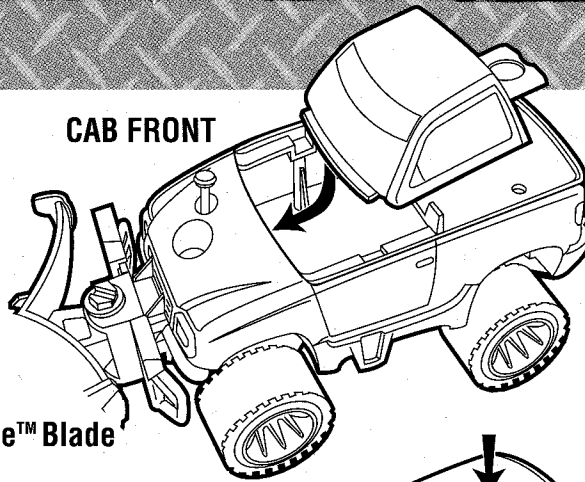

D. Place the lip on the front of the **Cab Front** under the vehicle's hood, then lower the cab front into position.

ROLLBAR LIGHT RACK

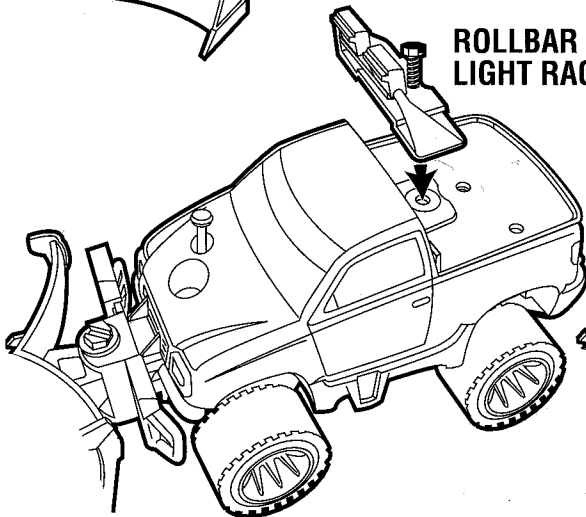

E. Place the **Rollbar/Light Rack** into position as shown. Tighten the screw with the Ratchet-Driver.

CAB BACK

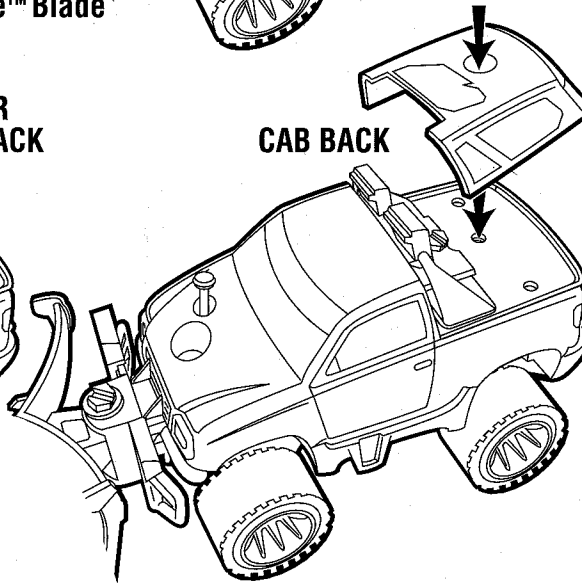

F. Place the **Cab Back** into position. Tighten the screw with the Ratchet-Driver.

GAS CANS

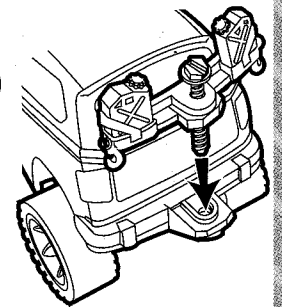

G. Screw the **Gas Cans** into the back bumper as shown. Tighten the screw with the Ratchet-Driver.

PLAY FEATURES

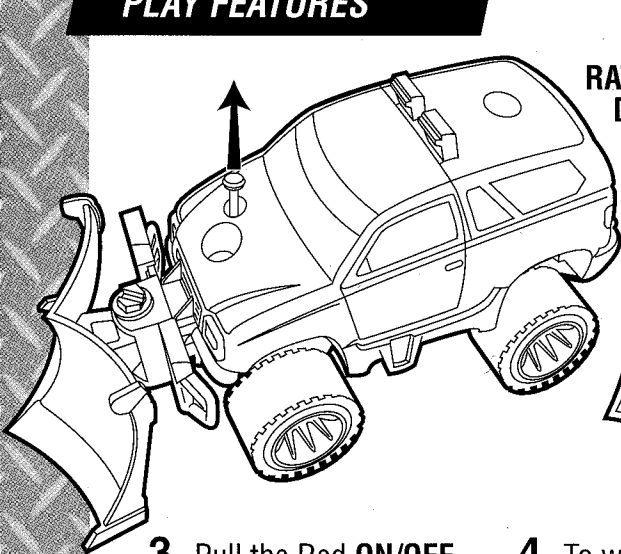

3. Pull the **Red ON/OFF Button** upwards to disengage the motor.

RATCHET- DRIVER

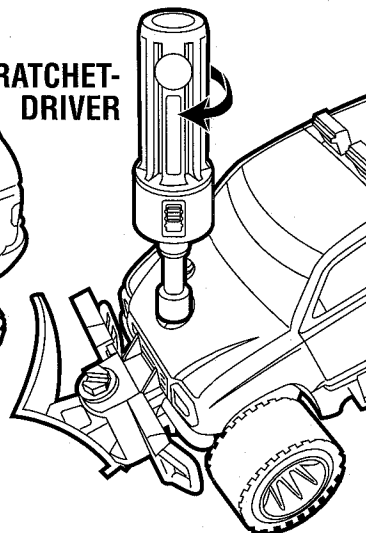

4. To wind up the motor, turn the screw next to the **ON/OFF Button** with the **Ratchet-Driver Tool**. **IMPORTANT:** Motor must be disengaged to wind. Turn this screw until it makes a "clicking" sound, approximately four (4) full turns.

Remove the Tool from the vehicle.

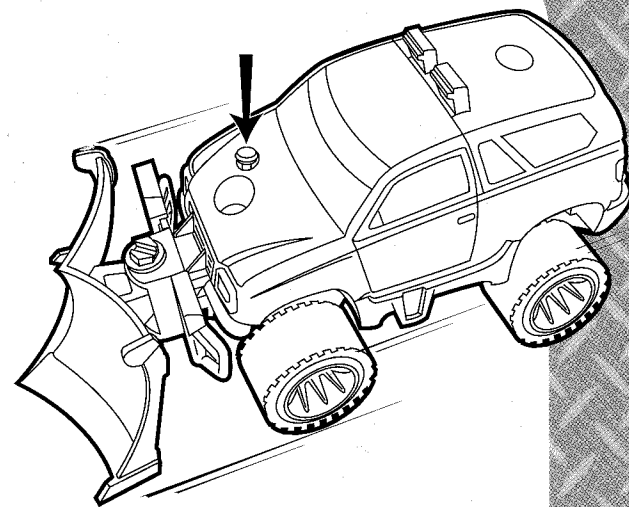

5. Push the **Red ON/OFF Button** down to let the vehicle "rip"!